

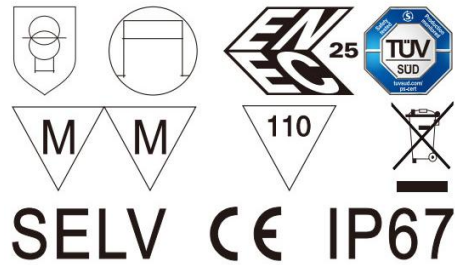

Constant Voltage Driver

Model: XSV Series



Model	Rated Input Voltage	Input Power	Input Current	PF	Output Power Range	Output Voltage	Output Current	Efficiency (typ.)
XSV60W48	220-240VAC	≤72W	≤0.4A	≥0.95	0-60W	48V	1.25A	88%
XSV100W48		≤115W	≤0.6A		0-100W		2.1A	90%
XSV160W48		≤180W	≤0.9A		0-160W		3.34A	92%
XSV240W48		≤265W	≤1.5A		0-240W		5A	92%
XSV400W48		≤435W	≤2.3A		0-400W		8.34A	93%

* Test result @230V, 50Hz, Full Load.

1.Parameters

category	Item	Technical Norm																													
Features	Output Type	Constant Voltage																													
	Dimming Type	NA																													
	Output Features	Isolation SELV																													
	IP Grade	IP67																													
	Installation	Independent																													
	Insulation Class	Class I																													
Input	Rated Input Voltage	220-240VAC																													
	Range of AC Input Voltage	176-264VAC																													
	Range of DC Input Voltage	175-280VDC (EMI not evaluated)																													
	Frequency	Rate:50/60Hz, Range:47~63Hz																													
	Power Factor	≥0.95, 220-240VAC, Rated Load, see graphs																													
	THD	≤10%, 230VAC, Rated Load, see graphs																													
	No Load Power Consumption	≤0.5W, @230VAC																													
	Inrush Current	<table border="1"> <thead> <tr> <th>Model</th> <th>IP</th> <th>IP (typ.)</th> <th>Duration time</th> <th>240Vac/50Hz, 90-degree phase, full load, cold start-up, duration time measure from 50%Ipk to 50%Ipk</th> </tr> </thead> <tbody> <tr> <td>60W</td> <td><30A</td> <td>26A</td> <td>220us</td> <td></td> </tr> <tr> <td>100W</td> <td><50A</td> <td>45A</td> <td>250us</td> <td></td> </tr> <tr> <td>160W</td> <td><60A</td> <td>56A</td> <td>250us</td> <td></td> </tr> <tr> <td>240W</td> <td><80A</td> <td>76A</td> <td>320us</td> <td></td> </tr> <tr> <td>400W</td> <td><100A</td> <td>88A</td> <td>430us</td> <td></td> </tr> </tbody> </table>	Model	IP	IP (typ.)	Duration time	240Vac/50Hz, 90-degree phase, full load, cold start-up, duration time measure from 50%Ipk to 50%Ipk	60W	<30A	26A	220us		100W	<50A	45A	250us		160W	<60A	56A	250us		240W	<80A	76A	320us		400W	<100A	88A	430us
Model	IP	IP (typ.)	Duration time	240Vac/50Hz, 90-degree phase, full load, cold start-up, duration time measure from 50%Ipk to 50%Ipk																											
60W	<30A	26A	220us																												
100W	<50A	45A	250us																												
160W	<60A	56A	250us																												
240W	<80A	76A	320us																												
400W	<100A	88A	430us																												

	Connected quantity of 16A Breaker	60W	16pcs, 16A type B / 26pcs 16A type C		
		100W	10pcs, 16A type B / 16pcs 16A type C		
		160W	8pcs, 16A type B / 13pcs 16A type C		
		240W	6pcs, 16A type B / 8pcs 16A type C		
		400W	4pcs, 16A type B / 5pcs 16A type C		
Output	Output Voltage	48VDC±3%			
	Rated Load Range	60W	24-60W		
		100W	30-100W		
		160W	48-160W		
		240W	72-240W		
		400W	120-400W		
	Output Voltage Ripple	<480mV _{PK-PK} (0.5%)			
	Line Regulation	±1%			
	Load Regulation	±2%			
	Overshoot	<105%V _o			
	Start-up Time	<0.5S (220-240VAC)			
	Efficiency	60W	≥86%	88% typ.	230VAC, Rated Load, at output terminals, see graphs
100W		≥90%	92% typ.		
160W		≥90%	92% typ.		
240W		≥90%	92% typ.		
400W		≥91%	93% typ.		
Protection	Short Circuit Protection	Auto Recovery			
	Over Current Protection	120%-200%I _o , Auto Recovery			
	Over Voltage Protection	120%-150%V _o , Auto Recovery			
	Over Temperature Protection	90<T _c <110°C, Auto Recovery			
	Insulation voltage	I/P to O/P, 3KV _{ac} /5mA/1min			
	Insulation resistance	>100M ohm @ 500VDC			
	Leakage current	I/P to O/P < 250μA			
Environment	Ta/Operation Temperature	-25....+50°C			
	Ts/Storage Temperature	-40....+85°C			
	Tc/Enclosure Temperature For Safety	60W/100W	75°C		
		160W	85°C		
		240W/400W	90°C		
	Humidity	5%....85%RH			
Atmosphere	86-108KPa				
Standards	Certification	CE			
	Safety Standards	EN61347-1:2015, EN61347-2-13:2014/A1:2017, EN62493:2015, AS61347.2.13:2018, AS/NZS 61347.1:2016 Inc A1			
	EMC Standards	EN55015:2013/A1:2015, EN61000-3-2:2014, EN61000-3-3:2013, EN61547:2009			
	Performance	EN62384			
	Surge	L-N:4KV, L/N-PE:6KV			

Others	RoHS	2011/65/EU		
	MTBF	≥250KHours, Ta=25°C (MIL-HDBK-217F)		
	Audible Noise	<25dB @ 10cm distance, 20dB background		
	Life Time	30W/60W/100W/160W	≥100K Hrs 65 °C case temperature, refer to life vs. Tc curve	
		240W/400W	≥100K Hrs 75 °C case temperature, refer to life vs. Tc curve	
	Warranty	5years		
	Dimensions (L*W*H)	60W	275*30*21MM (body), 290*30*21MM (endcaps included)	
		100W	305*30*21MM (body), 320*30*21MM (endcaps included)	
		160W	335*30*21MM (body), 350*30*21MM (endcaps included)	
		240W	385*30*21MM (body), 400*30*21MM (endcaps included)	
		400W	380*60*22MM (body), 400*60*22MM (endcaps included)	
	Wiring	Input	H05RN-F/3X1.0mm ² , Brown/Blue/(Yellow/Green)	
		Output	H05RN-F/2X1.0mm ² , Red/Black	
Output Cable Length	Max. 3M			

Remark:

1. All Parameters, if not specified, are measured at 230VAC/50Hz and 25°C ambient temperature.
2. LED Driver is a component of the luminaires, Luminaires and wire layout will affect the EMC, please check the EMC with end products again.
3. Output ripple should be measured at the output end which has with 0.1uF/100V ceramic capacitance and 10uF/100V Aluminum capacitance connected in parallel. Measured using oscilloscope with bandwidth limited to 20MHz.

2.Graph

PF VS LOAD Curve

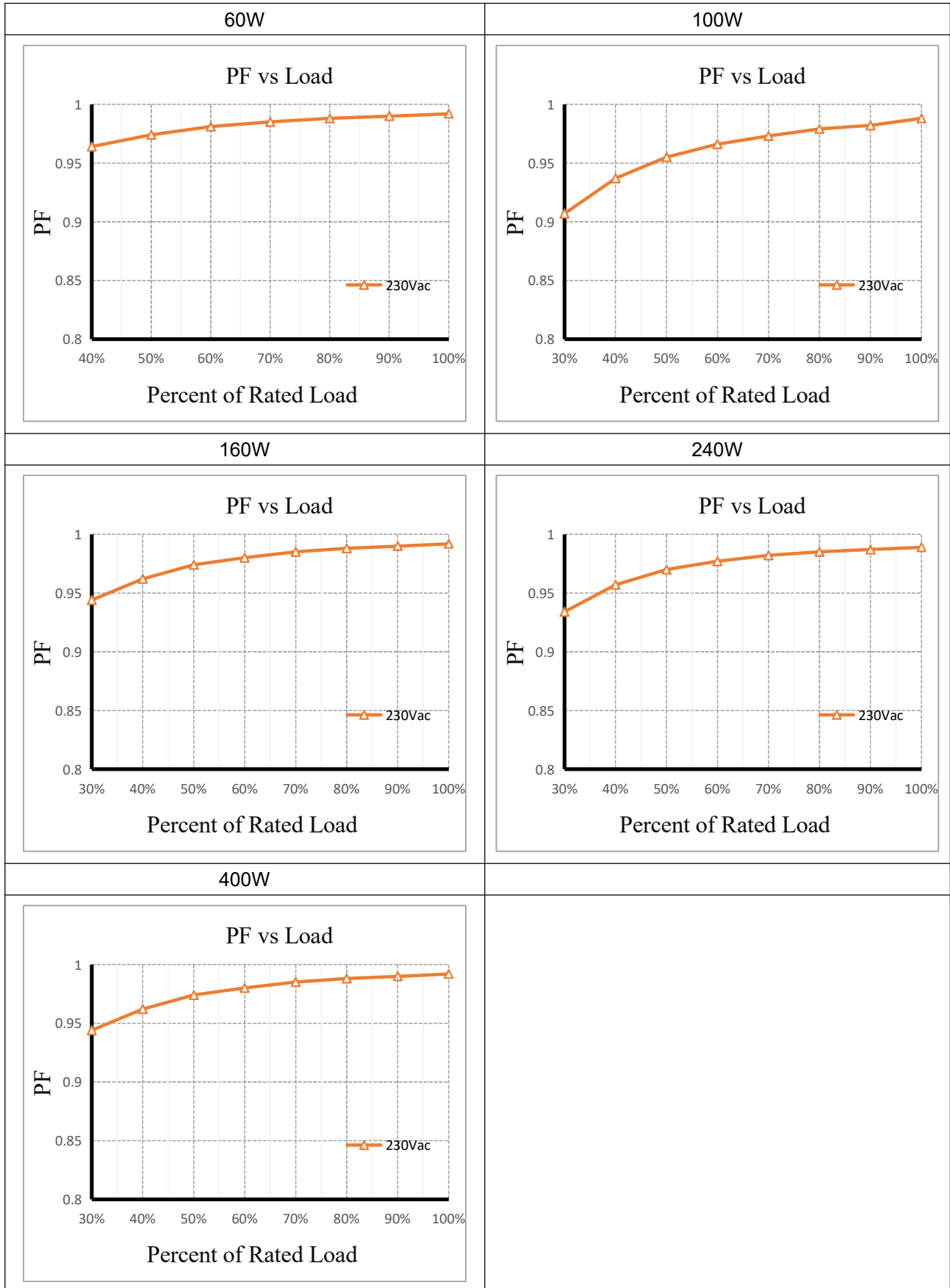

THD VS LOAD Curve

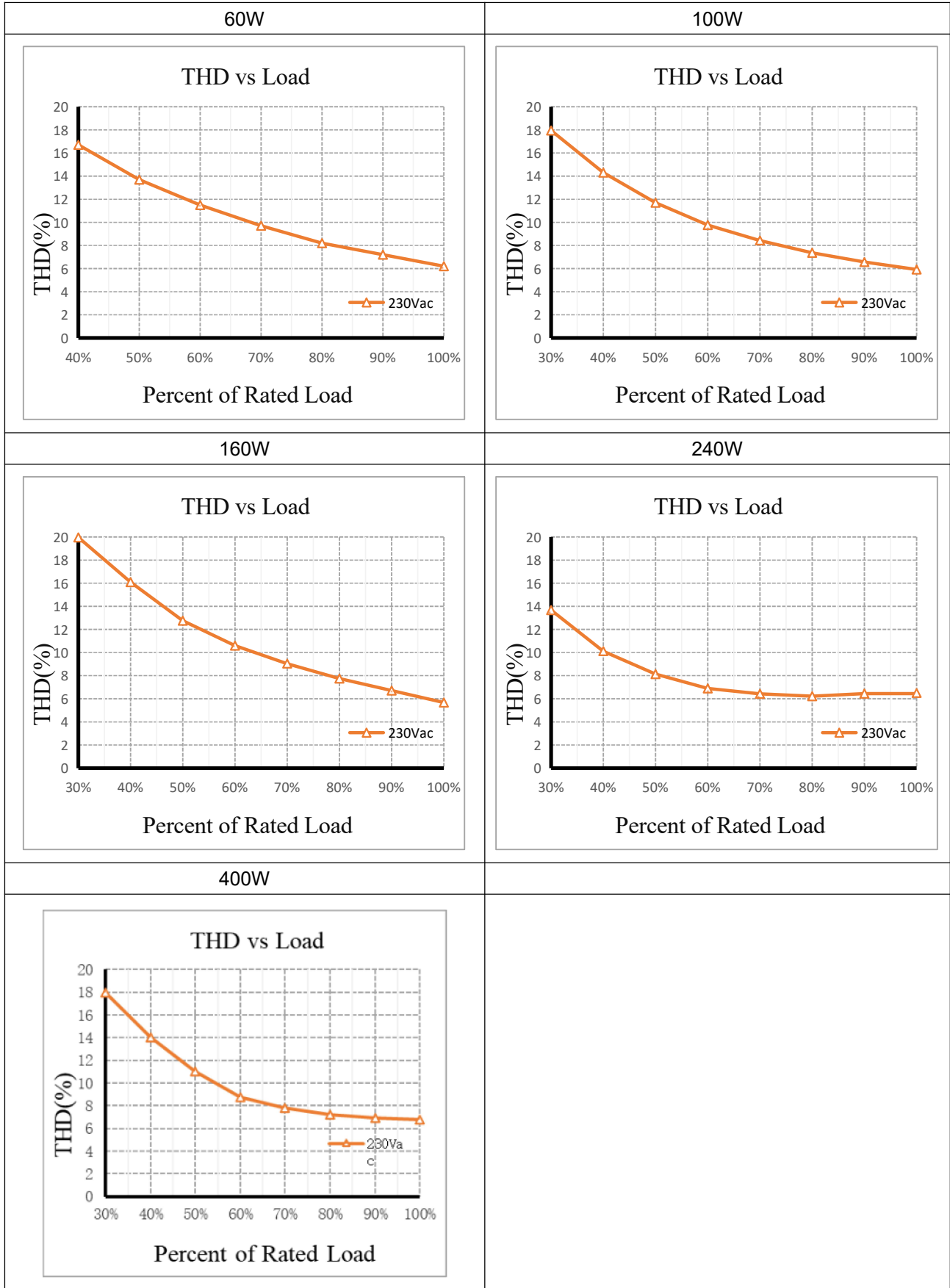

Efficiency VS LOAD Curve

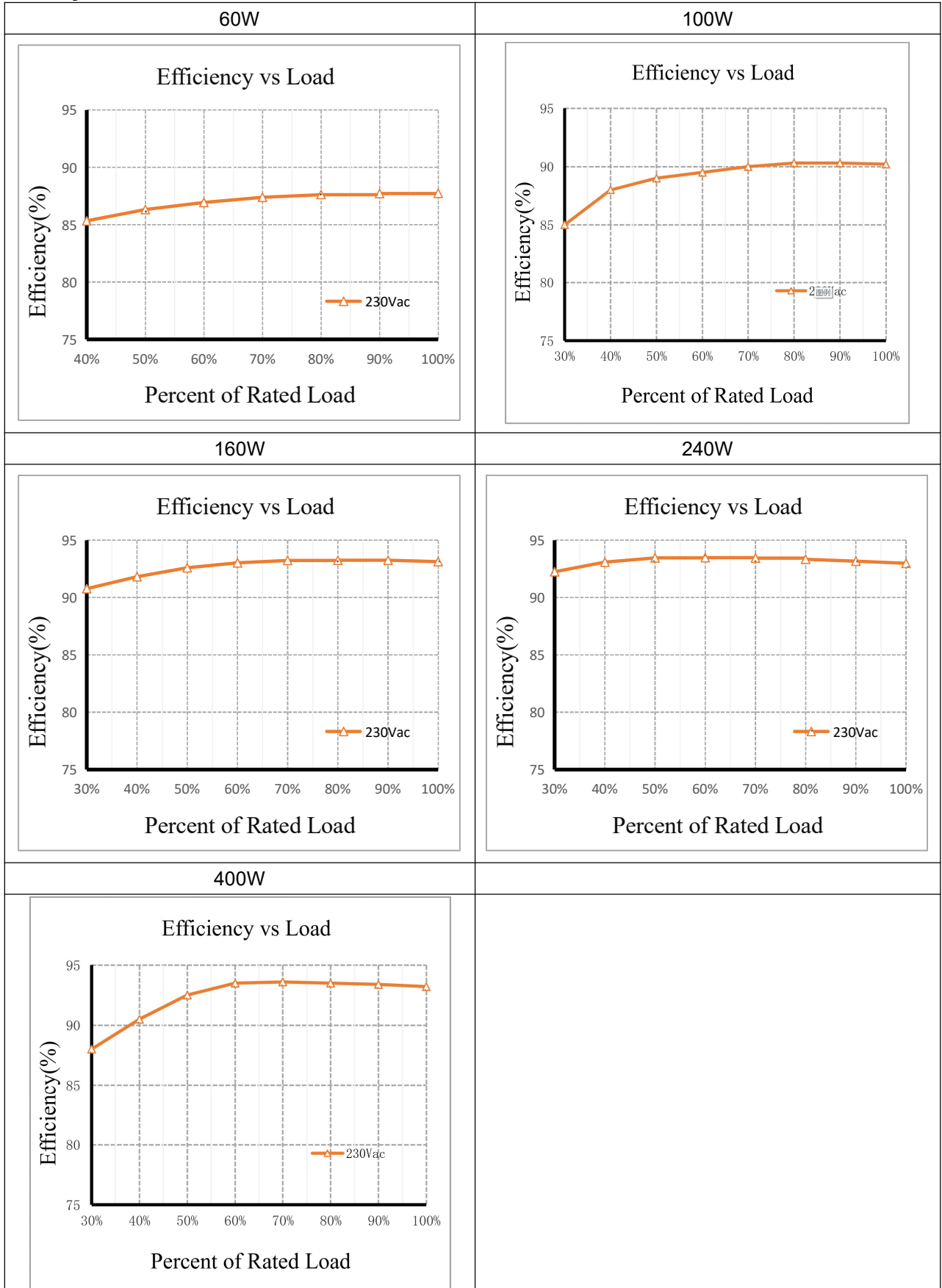

Lifetime vs. Case Temperature

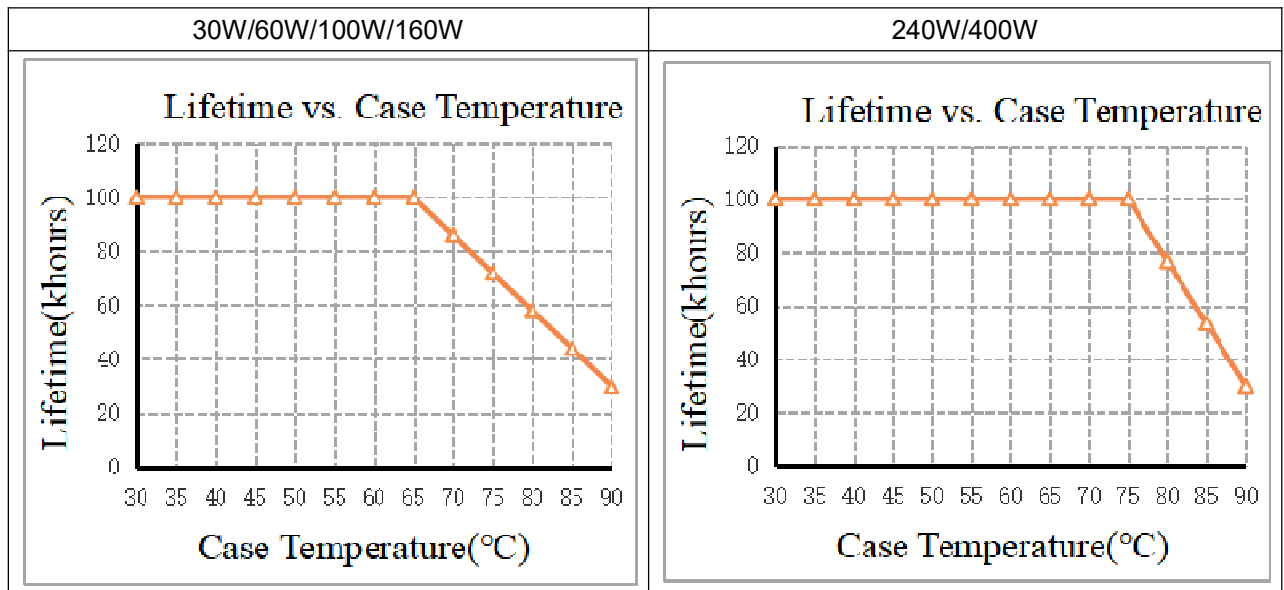

(End of Life: Maximum Failure Rate=10%)

3.Label

○ L (Brown)	KGP KGP Electronics GmbH Hueckstraße 19 DE-58511 Lüdenscheid	XSV60W48 LED Driver Constant Voltage Type For LED modules only	Input: 220-240V~, 50/60Hz, 0.4A, λ:0.95 Output: 48V-0-1.25A Max.60W *tc Ta: -25 ~ +50°C Tc:75°C	(Black) ⊕ (Red) ⊕ output
○ N (Blue)				
○ (Yellow-green)				

SELV CE ENEC IP67

○ L (Brown)	KGP KGP Electronics GmbH Hueckstraße 19 DE-58511 Lüdenscheid	XSV100W48 LED Driver Constant Voltage Type For LED modules only	Input: 220-240V~, 50/60Hz, 0.6A, λ:0.95 Output: 48V-0-2.1A Max.100W *tc Ta: -25 ~ +50°C Tc:75°C	(Black) ⊕ (Red) ⊕ output
○ N (Blue)				
○ (Yellow-green)				

SELV CE ENEC IP67

○ L (Brown)	KGP KGP Electronics GmbH Hueckstraße 19 DE-58511 Lüdenscheid	XSV160W48 LED Driver Constant Voltage Type For LED modules only	Input: 220-240V~, 50/60Hz, 0.9A, λ:0.95 Output: 48V-0-3.34A Max.160W *tc Ta: -25 ~ +50°C Tc:85°C	(Black) ⊕ (Red) ⊕ output
○ N (Blue)				
○ (Yellow-green)				

SELV CE ENEC IP67

○ L (Brown)	KGP KGP Electronics GmbH Hueckstraße 19 DE-58511 Lüdenscheid	XSV240W48 LED Driver Constant Voltage Type For LED modules only	Input: 220-240V~, 50/60Hz, 1.5A, λ:0.95 Output: 48V-0-6A Max.240W *tc Ta: -25 ~ +50°C Tc:90°C	(Black) ⊕ (Red) ⊕ output
○ N (Blue)				
○ (Yellow-green)				

SELV CE ENEC IP67

○ L (Brown)	KGP KGP Electronics GmbH Hueckstraße 19 DE-58511 Lüdenscheid	XSV400W48 LED Driver Constant Voltage Type For LED modules only	Input: 220-240V~, 50/60Hz, 2.3A, λ:0.95 Output: 48V-0-8.34A Max.400W *tc Ta: -25 ~ +50°C Tc:90°C	(Black) ⊕ (Red) ⊕ output
○ N (Blue)				
○ (Yellow-green)				

SELV CE ENEC IP67

4.Dimension (Unit: mm)

XSV60W48

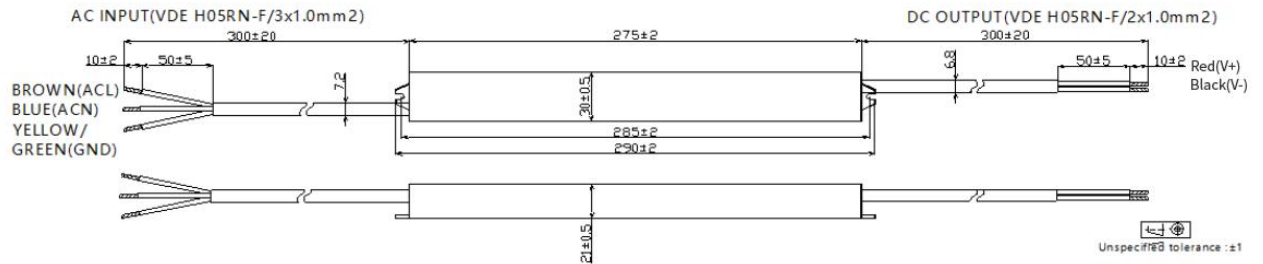

XSV100W48

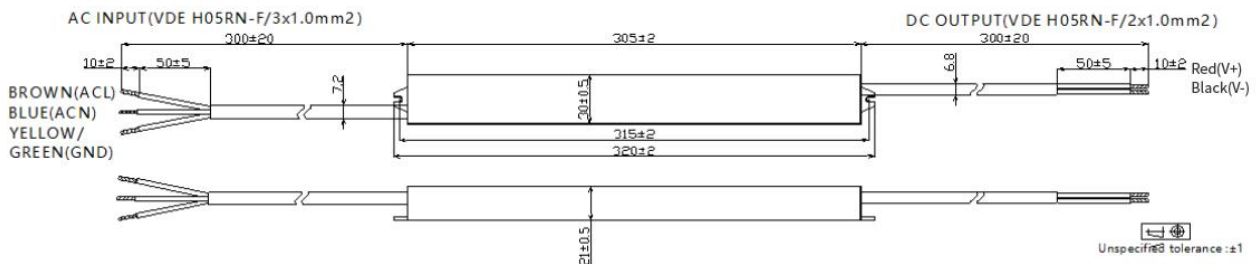

XSV160W48

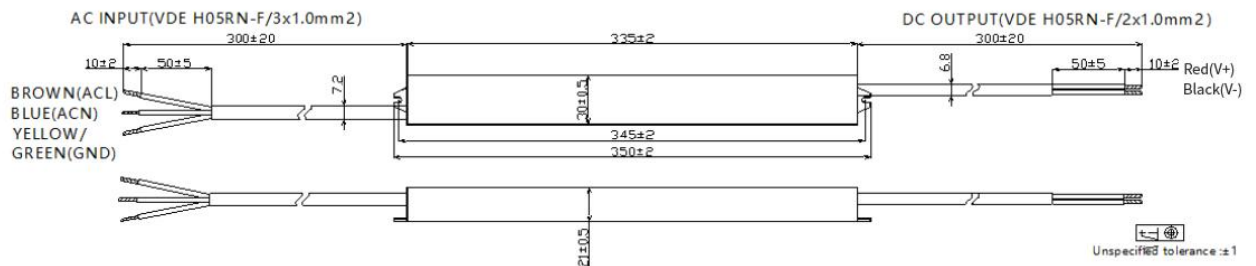

XSV240W48

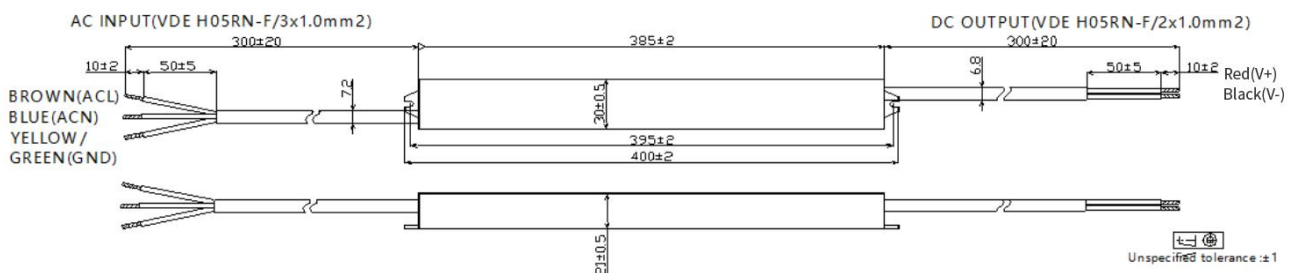

XSV400W48

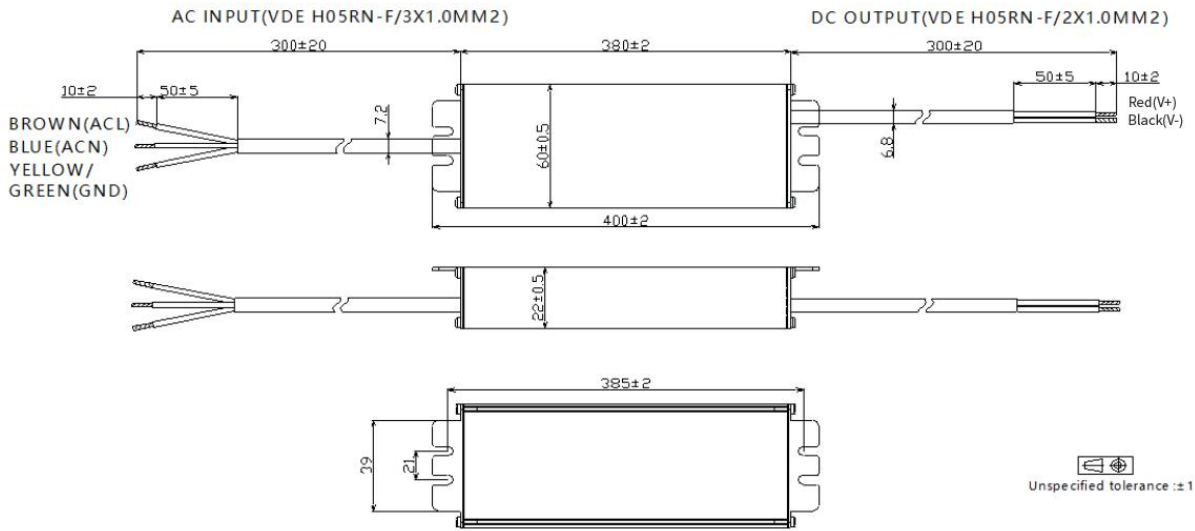

5. Wiring Diagram

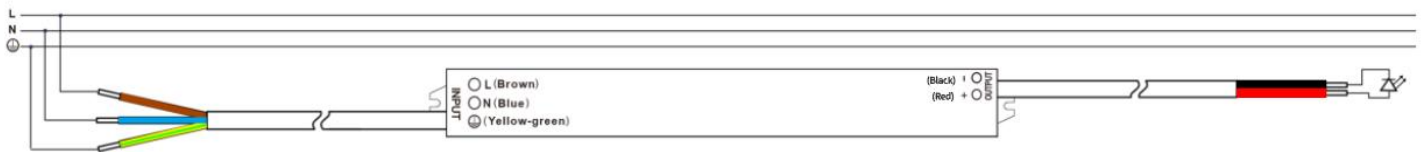

6. Packing information

Model	Carton L*W*H(cm)	Pcs/ Carton	Net weight/ Pcs(g)	Net weight/ Carton(kg)	Gross weight/ Carton(kg)
XSV60W48	34*29*20	30	390	11.7	13.3
XSV100W48	39*29*20	30	420	12.6	14.3
XSV160W48	39*29*20	30	470	14.1	15.8
XSV240W48	44*29*14	20	530	10.6	11.9
XSV400W48	44*29*14	12	1050	12.6	13.6

7.REVISION HISTORY

Date	Revision	Remark
2021-12-06	A	Preliminary Edition
2022-3-06	B	Standard Edition
2024-5-17	C	Add ENEC certification mark
2024-08-12	D	Add life vs. Tc curve
2024-09-28	E	Update carton qty
2024-10-26	F	Output wire color change to red/black