

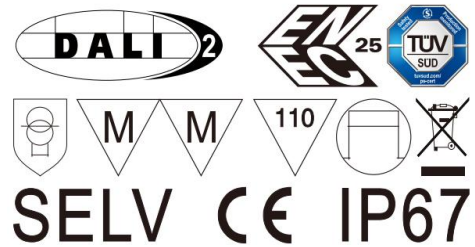

Constant Voltage Driver

Model: XSV DALI Series



Model	Rated Input Voltage	Input Power	Input Current	PF	Output Power Range	Output Voltage	Output Current	Efficiency (typ.)
XSV30W24 DALI	220-240VAC	≤36W	≤0.2A	≥0.95	0-30W	24V	1.25A	86%
XSV60W24 DALI		≤72W	≤0.4A		0-60W		2.5A	88%
XSV100W24 DALI		≤115W	≤0.6A		0-100W		4.17A	90%
XSV160W24 DALI		≤180W	≤0.9A		0-160W		6.67A	92%
XSV240W24 DALI		≤265W	≤1.5A		0-240W		10A	92%
XSV400W24 DALI		≤435W	≤2.3A		0-400W		16.67A	93%

* Test result @230V, 50Hz, Full Load.

1.Parameters

category	Item	Technical Norm						
Features	Output Type	Constant Voltage						
	Dimming Type	DALI-2						
	Output Features	Isolation SELV						
	IP Grade	IP67						
	Installation	Independent						
	Insulation Class	Class I						
Input	Rated Input Voltage	220-240VAC						
	Range of AC Input Voltage	176-264VAC						
	Range of DC Input Voltage	175-280VDC (EMI not evaluated)						
	Frequency	Rate:50/60Hz, Range:47~63Hz						
	Power Factor	≥0.95, 220-240VAC, Rated Load, see graphs						
	THD	≤10%, 230VAC, Rated Load, see graphs						
	Standby Power Consumption	≤0.5W, @230VAC, Dim to OFF						
	Inrush Current	Model	IP	IP (typ.)	Duration time	240Vac/50Hz, 90-degree phase, full load, cold start-up, duration time measure from 50%Ipk to 50%Ipk		
	30W	<30A	25A	200us				
	60W	<30A	26A	220us				
	100W	<50A	45A	250us				
	160W	<60A	56A	250us				

		240W	<80A	76A	320us	
		400W	<100A	88A	430us	
	Connected quantity of 16A Breaker	30W	16pcs, 16A type B / 26pcs 16A type C			
		60W	16pcs, 16A type B / 26pcs 16A type C			
		100W	10pcs, 16A type B / 16pcs 16A type C			
		160W	8pcs, 16A type B / 13pcs 16A type C			
		240W	6pcs, 16A type B / 8pcs 16A type C			
400W	4pcs, 16A type B / 5pcs 16A type C					
Output	Output Voltage	24VDC±3%				
	Rated Load Range	30W	9-30W			
		60W	24-60W			
		100W	30-100W			
		160W	48-160W			
		240W	72-240W			
		400W	120-400W			
	Output Voltage Ripple	<240mV _{PK-PK} (0.5%)				
	Line Regulation	±1%				
	Load Regulation	±2%				
	Overshoot	<105%Vo (<110%Vo, only for 30W)				
	Start-up Time	0.6S(typ.) (220-240VAC)				
	Efficiency	30W	≥84%	86% typ.	230VAC, Rated Load, at output terminals, see graphs	
60W		≥86%	88% typ.			
100W		≥90%	92% typ.			
160W		≥90%	92% typ.			
240W		≥90%	92% typ.			
400W		≥91%	93% typ.			
Protection	Short Circuit Protection	Auto Recovery				
	Over Current Protection	120%-200%Io, Auto Recovery				
	Over Voltage Protection	120%-150%Vo, Auto Recovery				
	Over Temperature Protection	90<Tc<110°C, Auto Recovery				
	Insulation voltage	I/P to O/P, 3KVac/5mA/1min				
	Insulation resistance	>100M ohm @ 500VDC				
	Leakage current	I/P to O/P < 250µA				
Control Method	PUSH dimming	PUSH dimming (Max. lead wire length: 20m, same port of DALI)				
	PUSH Dimming Synchronization	The power connected to the same PUSH switch can be synchronized by pressing and holding the PUSH switch for longer than 10S.				
	DALI function	DALI dimming (Max. lead wire length: 300m) logarithm or linear dimming curve selectable				
	Dimming range	DALI dimming: 1%-100%, (1KHz)				
Environment	Ta/Operation Temperature	-25....+50°C				
	Ts/Storage Temperature	-40....+85°C				

	Tc/Enclosure Temperature For Safety	30W/60W/100W	75°C	
		160W	85°C	
		240W/400W	90°C	
	Humidity	5%....85%RH		
	Atmosphere	86-108KPa		
Standards	Certification	CE		
	Safety Standards	EN61347-1:2015, EN61347-2-13:2014/A1:2017, EN62493:2015, AS61347.2.13:2018, AS/NZS 61347.1:2016 Inc A1		
	EMC Standards	EN55015:2013/A1:2015, EN61000-3-2:2014, EN61000-3-3:2013, EN61547:2009		
	Performance	EN62384; IEC 62386-101 Edition 2.0 2014-11; BS EN 62386-102:2014 ; BS EN 62386-207:2009		
	Surge	L-N:4KV, L/N-PE:6KV		
Others	RoHS	2011/65/EU		
	MTBF	≥250KHours, Ta=25°C (MIL-HDBK-217F)		
	Audible Noise	<25dB @ 10cm distance, 20dB background		
	Life Time	30W/60W/100W/160W	≥100K Hrs 65 °C case temperature, refer to life vs. Tc curve	
		240W/400W	≥100K Hrs 75 °C case temperature, refer to life vs. Tc curve	
	Warranty	5years		
	Dimensions (L*W*H)	30W	235*30*21MM (body), 250*30*21MM (endcaps included)	
		60W	275*30*21MM (body), 290*30*21MM (endcaps included)	
		100W	305*30*21MM (body), 320*30*21MM (endcaps included)	
		160W	335*30*21MM (body), 350*30*21MM (endcaps included)	
240W		385*30*21MM (body), 400*30*21MM (endcaps included)		
400W		385*60*22MM (body), 400*60*22MM (endcaps included)		
Wiring	Input	H05RN-F/3X1.0mm ² , Brown/Blue/(Yellow/Green)		
	Output	H05RN-F/2X1.0mm ² , Red/Black (Two cables are connected in parallel for 400W)		
	DALI	H05RN-F/2X0.75mm ² , Purple/Gray		
	Output Cable Length	Max. 1M		

Remark:

- All Parameters, if not specified, are measured at 230VAC/50Hz and 25°C ambient temperature.
- LED Driver is a component of the luminaires, Luminaires and wire layout will affect the EMC, please check the EMC with end products again.
- Output ripple should be measured at the output end which has with 0.1uF/50V ceramic capacitance and 47uF/50V Aluminum capacitance connected in parallel. Measured using oscilloscope with bandwidth limited to 20MHz.

2.Graph PF VS LOAD Curve

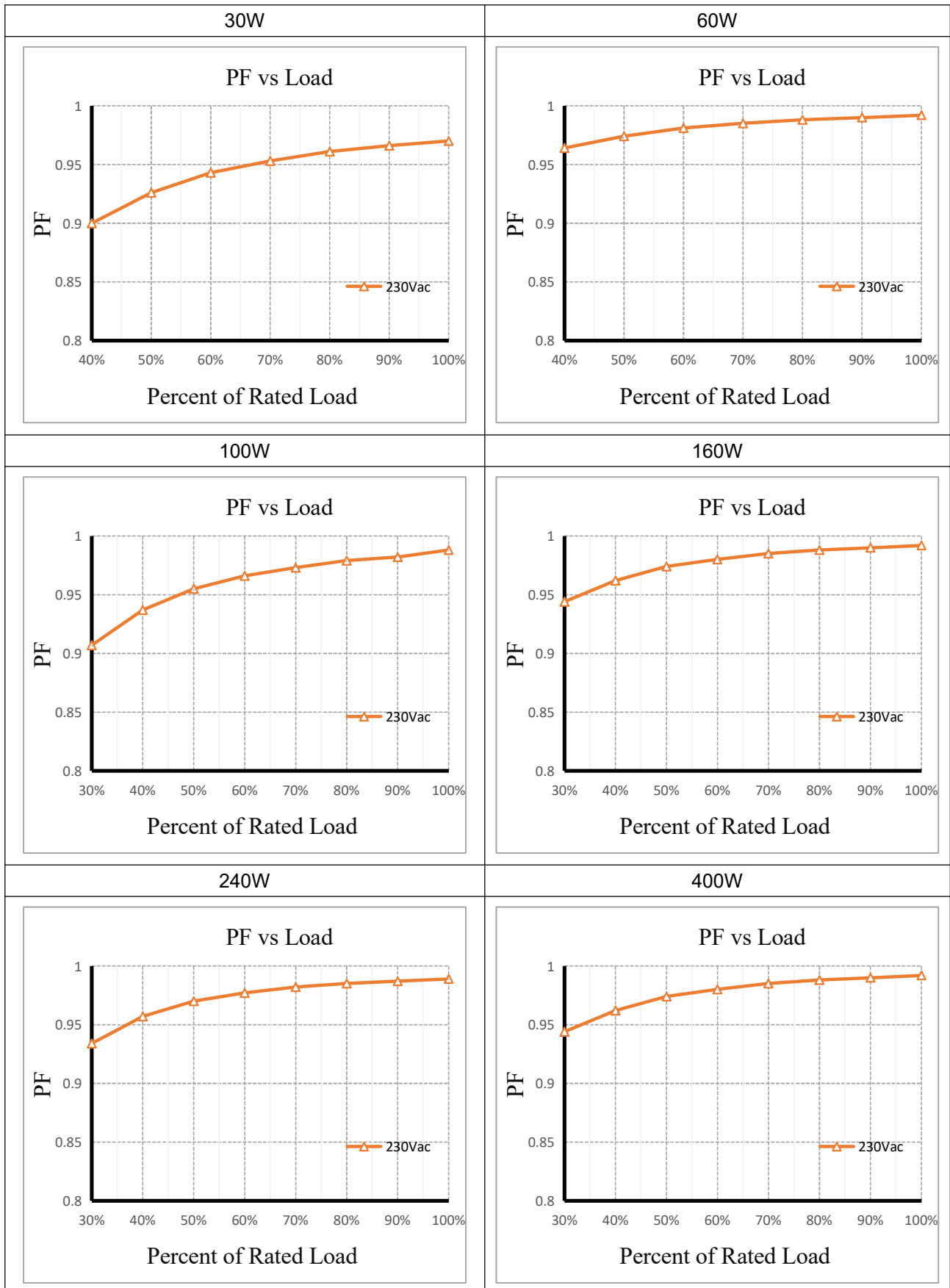

THD VS LOAD Curve

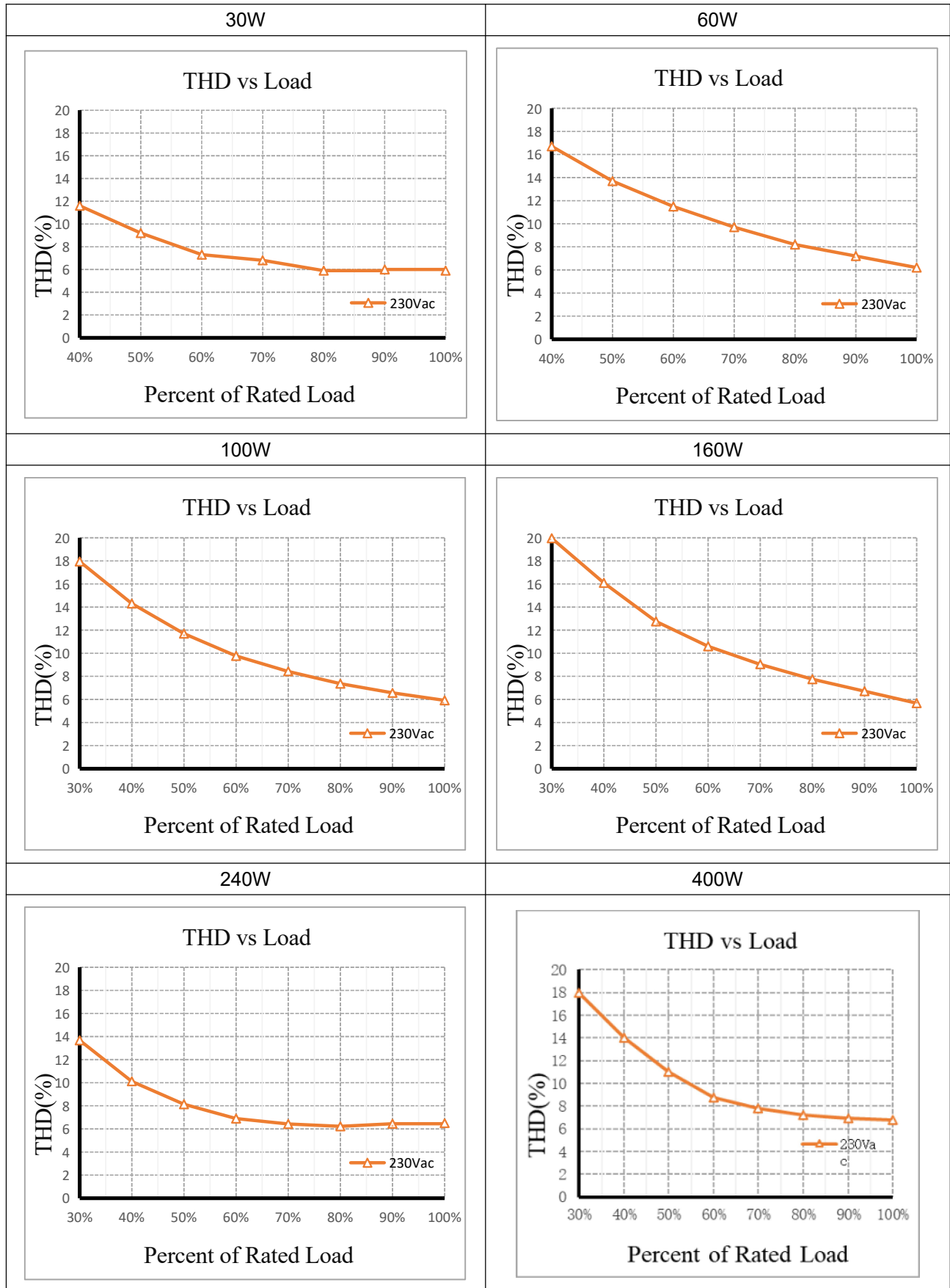

Efficiency VS LOAD Curve

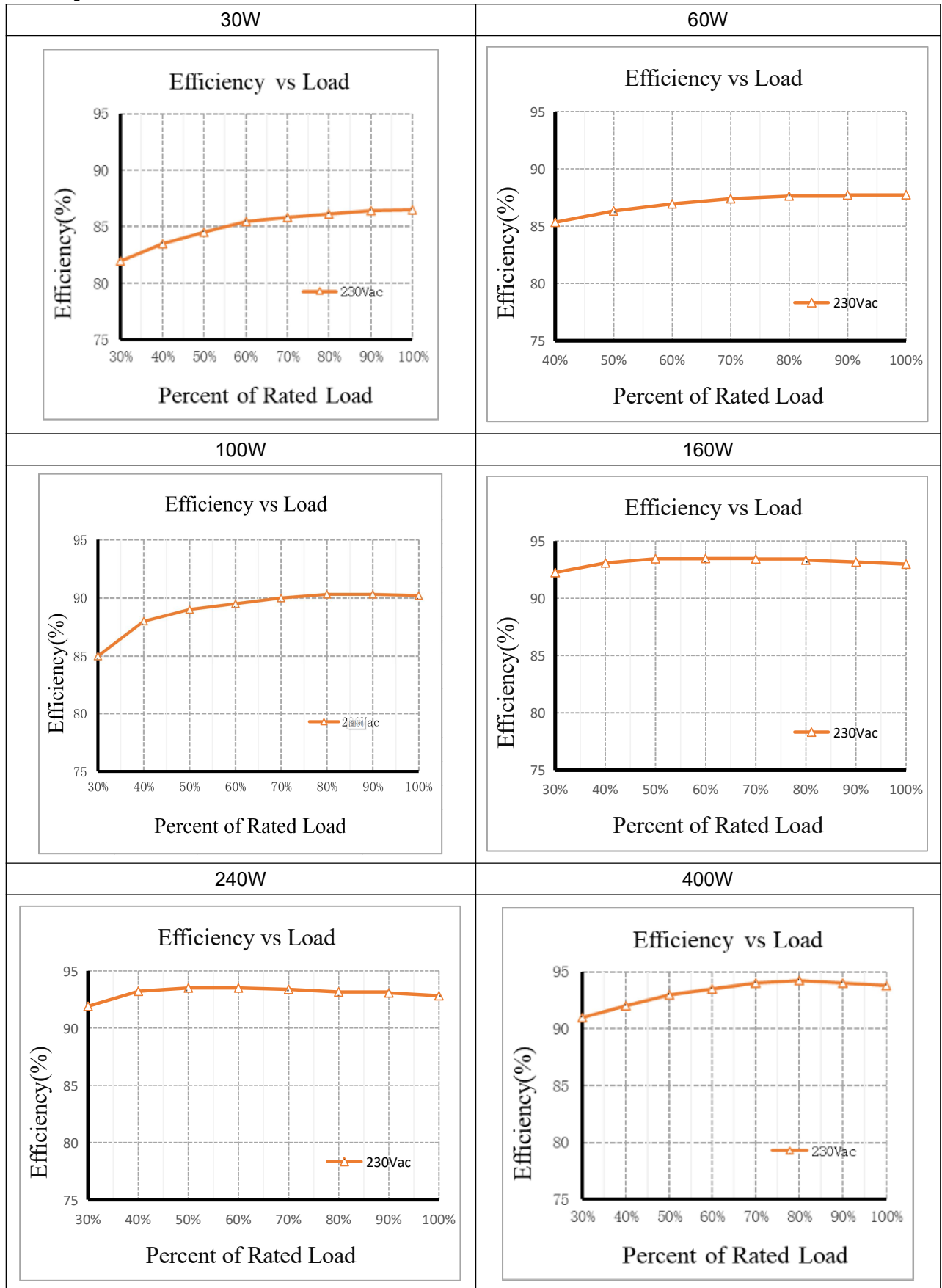

Lifetime vs. Case Temperature

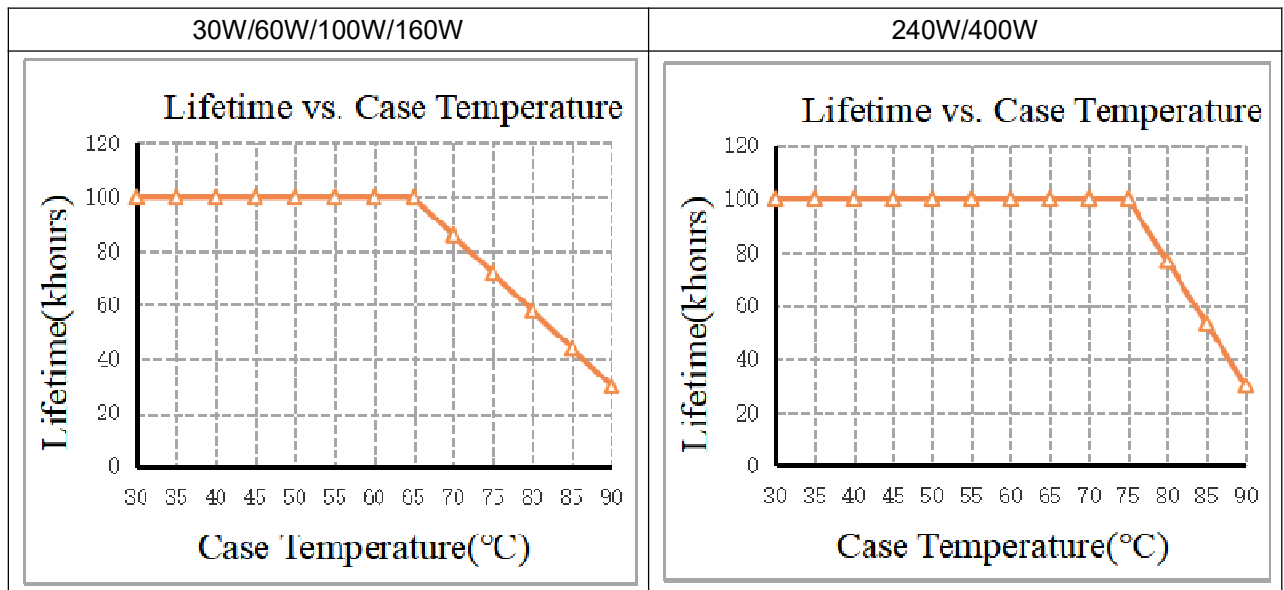

(End of Life: Maximum Failure Rate=10%)

3.DALI dimming curve

3.1 formula for DALI dimming.

$$X(n) = 10^{\left\{ \frac{(n-1)}{(253/3)} - 1 \right\}}$$

Here, n means the target dimming stage of the total 254 stages.

X(n) means the percent of the maximum output current

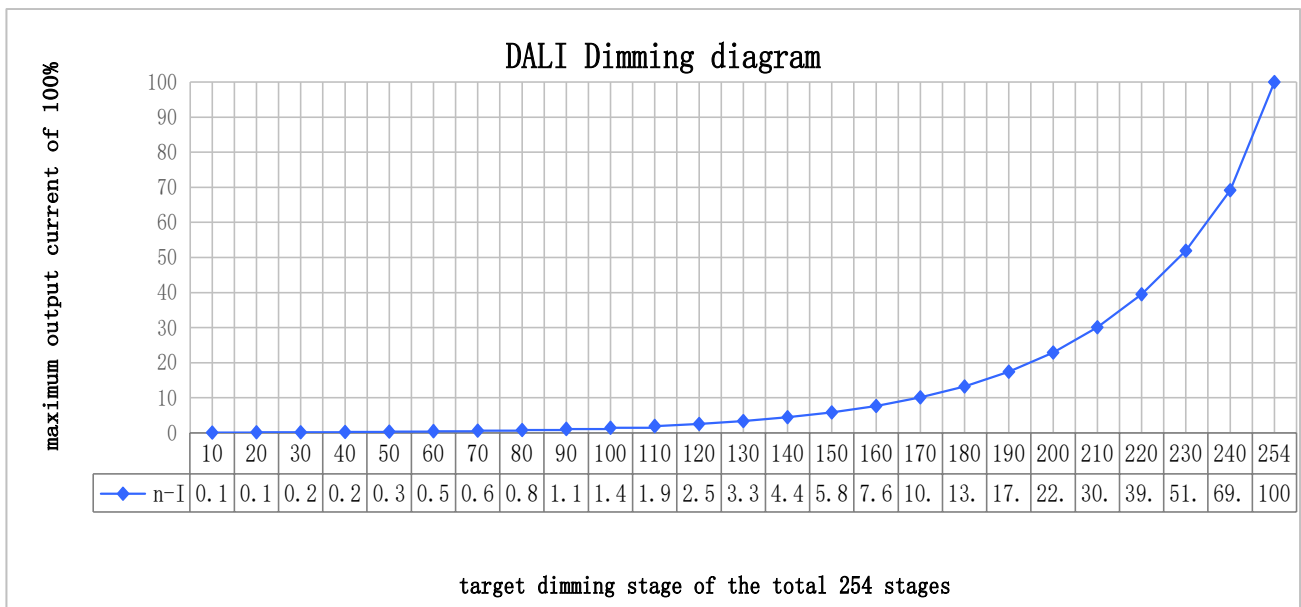

4.Label

L (Brown)
 N (Blue)
 (Yellow-green)

KGP
 KGP Electronics GmbH
 Hueckstraße 19
 DE-58511 Lüdenscheid

XSV30W24 DALI
 Dimmable LED Driver
 Constant Voltage Type
 For LED modules only

Input: 220-240V~, 50/60Hz, 0.2A, $\lambda: 0.95$
 Output: 24V-0-1.25A Max.30W
 *tc Ta: -25 ~ +50°C Tc:75°C

(Black) I
 (Red) +
 OUTPUT

(Purple) DA
 (Gray) DA
 DIM

L (Brown)
 N (Blue)
 (Yellow-green)

KGP
 KGP Electronics GmbH
 Hueckstraße 19
 DE-58511 Lüdenscheid

XSV60W24 DALI
 Dimmable LED Driver
 Constant Voltage Type
 For LED modules only

Input: 220-240V~, 50/60Hz, 0.4A, $\lambda: 0.95$
 Output: 24V-0-2.5A Max.60W
 *tc Ta: -25 ~ +50°C Tc:75°C

(Black) I
 (Red) +
 OUTPUT

(Purple) DA
 (Gray) DA
 DIM

L (Brown)
 N (Blue)
 (Yellow-green)

KGP
 KGP Electronics GmbH
 Hueckstraße 19
 DE-58511 Lüdenscheid

XSV100W24 DALI
 Dimmable LED Driver
 Constant Voltage Type
 For LED modules only

Input: 220-240V~, 50/60Hz, 0.6A, $\lambda: 0.95$
 Output: 24V-0-4.17A Max.100W
 *tc Ta: -25 ~ +50°C Tc:75°C

(Black) I
 (Red) +
 OUTPUT

(Purple) DA
 (Gray) DA
 DIM

L (Brown)
 N (Blue)
 (Yellow-green)

KGP
 KGP Electronics GmbH
 Hueckstraße 19
 DE-58511 Lüdenscheid

XSV180W24 DALI
 Dimmable LED Driver
 Constant Voltage Type
 For LED modules only

Input: 220-240V~, 50/60Hz, 0.9A, $\lambda: 0.95$
 Output: 24V-0-6.67A Max.160W
 *tc Ta: -25 ~ +50°C Tc:85°C

(Black) I
 (Red) +
 OUTPUT

(Purple) DA
 (Gray) DA
 DIM

L (Brown)
 N (Blue)
 (Yellow-green)

KGP
 KGP Electronics GmbH
 Hueckstraße 19
 DE-58511 Lüdenscheid

XSV240W24 DALI
 Dimmable LED Driver
 Constant Voltage Type
 For LED modules only

Input: 220-240V~, 50/60Hz, 1.5A, $\lambda: 0.95$
 Output: 24V-0-10A Max.240W
 *tc Ta: -25 ~ +50°C Tc:90°C

(Black) I
 (Red) +
 OUTPUT

(Purple) DA
 (Gray) DA
 DIM

L (Brown)
 N (Blue)
 (Yellow-green)

KGP
 KGP Electronics GmbH
 Hueckstraße 19
 DE-58511 Lüdenscheid

XSV400W24 DALI
 Dimmable LED Driver
 Constant Voltage Type
 For LED modules only

Input: 220-240V~, 50/60Hz, 2.3A, $\lambda: 0.95$
 Output: 24V-0-16.67A Max.400W
 *tc Ta: -25 ~ +50°C Tc:90°C

(Black) I
 (Red) +
 OUTPUT

(Black) I
 (Red) +
 (Purple) DA
 (Gray) DA
 DIM

5.Dimension (Unit: mm)

XSV30W24 DALI

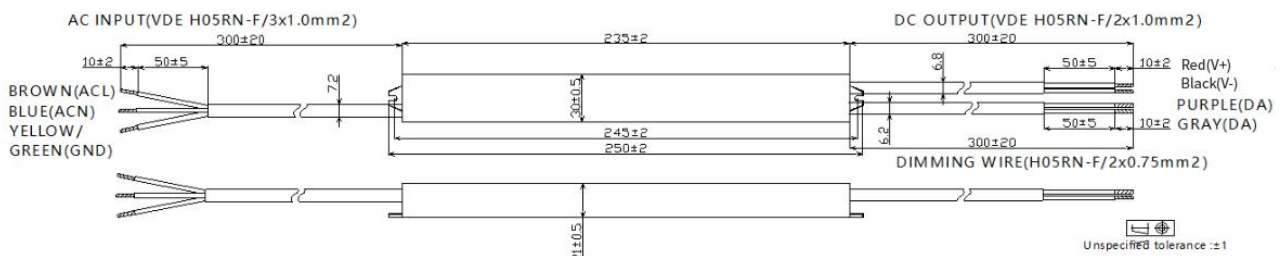

XSV60W24 DALI

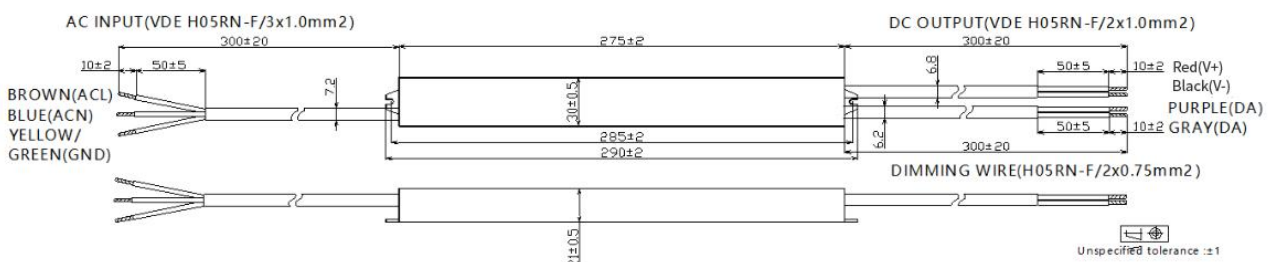

XSV100W24 DALI

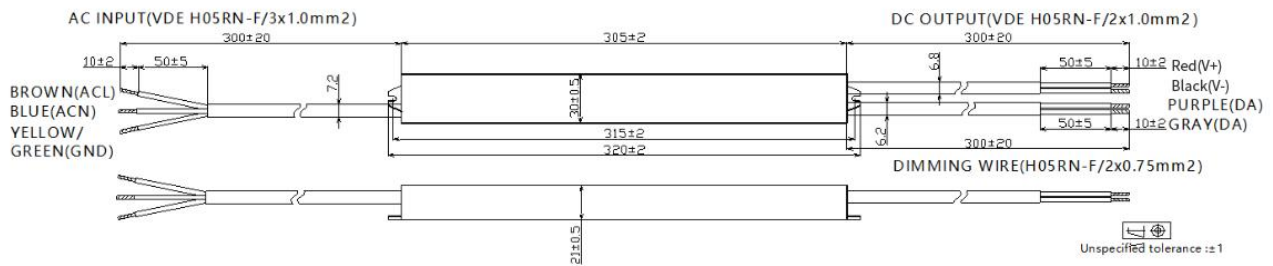

XSV160W24 DALI

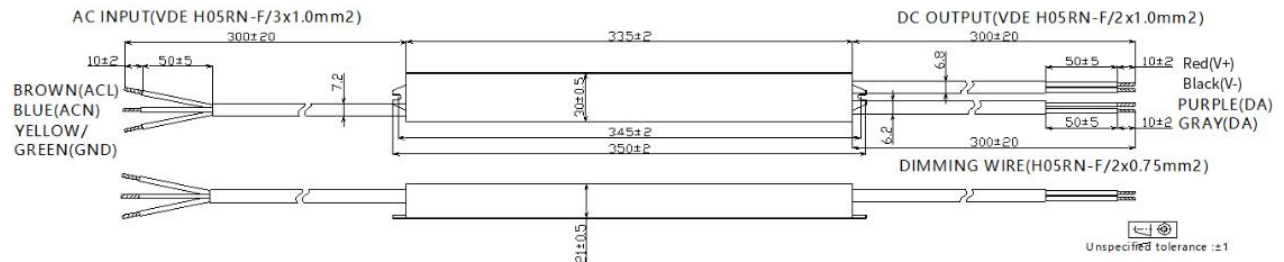

XSV240W24 DALI

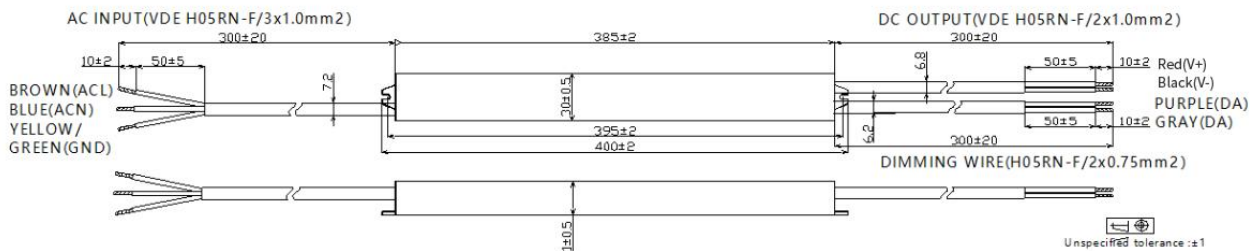

XSV400W24 DALI

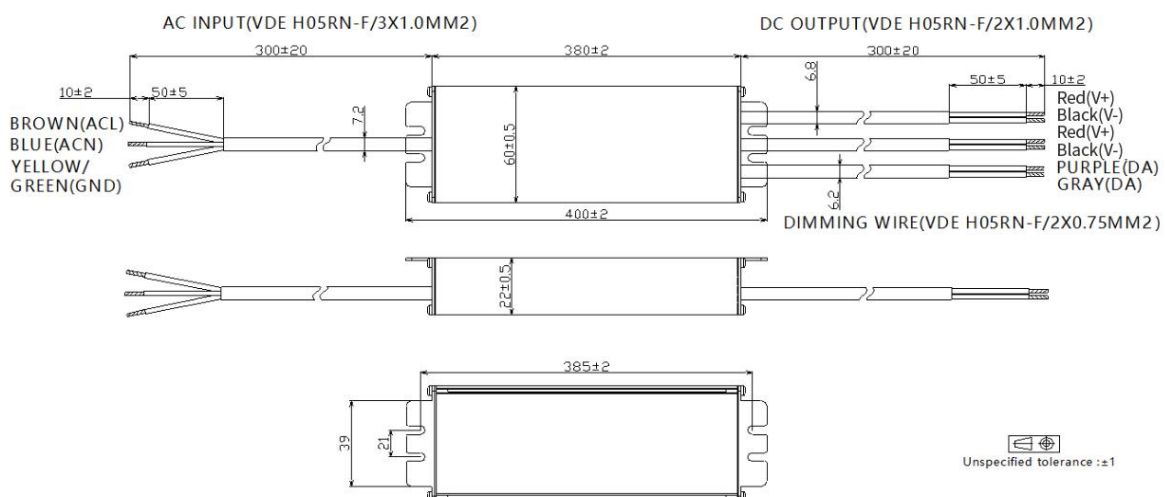

Remark: Two output cables are in parallel inside the drive, and the current of each cable does not exceed 10A.

6.Wiring Diagram

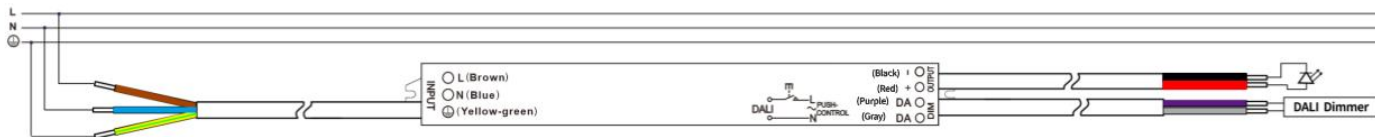

7.Packing information

Model	Carton L*W*H(cm)	Pcs/ Carton	Net weight/ Pcs(g)	Net weight/ Carton(kg)	Gross weight/ Carton(kg)
XSV30W24 DALI	34*29*20	30	340	10.2	11.8
XSV60W24 DALI	34*29*20	30	390	11.7	13.3
XSV100W24 DALI	39*29*20	30	420	12.6	14.3
XSV160W24 DALI	39*29*20	30	470	14.1	15.8
XSV240W24 DALI	44*29*14	20	530	10.6	11.9
XSV400W24 DALI	44*29*14	12	1050	12.6	13.6

8.REVISION HISTORY

Date	Revision	Remark
2021-08-30	A	Preliminary Edition
2021-11-15	B	Add 400W, update packing information
2024-05-17	C	Minimum Rated Load Range of 30W , changed from 12W to 9W ; Add ENEC certification mark
2024-08-12	D	Add life vs. Tc curve
2024-09-28	E	Update carton qty
2024-10-26	F	Output wire color change to red/black