

XRCXXXWYYYY-YYYY\*

## Constant Current Driver

Model: XRC120W400-600\*  
 XRC160W500-800\*  
 XRC200W700-1000\*  
 XRC240W840-1200\*  
 XRC300W1100-1500\*



Model	Input Current	Input Voltage Range	Rated Output Power	Output Current	Rated Output Voltage	Typical Efficiency	PF	No load Voltage
XRC120W400-600*	1.5A.max	120-277VAC	72- 120W	0.4-0.6A	180-260V	0.92	0.95	350V
XRC160W500-800*	1.9A.max	120-277VAC	90- 160W	0.5-0.8A	180-260V	0.93	0.95	350V
XRC200W700-1000*	2.3A.max	120-277VAC	126-200W	0.7- 1.0A	180-260V	0.94	0.95	350V
XRC240W840-1200*	2.8A.max	120-277VAC	150-240W	0.84- 1.2A	180-260V	0.95	0.95	350V
XRC300W1100-1500	2.8A.max	120-277VAC	200-300W	0.84-1.4A	180-260V	0.95	0.95	350V

\* Test result @230V, 50Hz, Full Load.

\* meaning different version : BH=Three in one dimming+12V auxiliary power supply+turn off to remove afterglow; 0-10V=0-10V version; =standard version

## 1. Parameters

Category	Item	Technical Norm
Features	Output Type	Constant Current
	Dimming Type	0- 10V
	Dimming Range	0%- 100%
	IP Grade	IP65
	Insulation Class	Class I
Input	Rated Input Voltage	120-277VAC
	Range of Input Voltage	90-305VAC
	Frequency	0/50/60Hz
	Input Current	≤ 1.5A@ 120W ; ≤ 1.9A@ 160W ≤ 2.3A@ 200W ; ≤ 2.8A@ 240W ≤ 2.8A@ 300W
	Power Factor	≥0.95
	THD	Full load @230V≤ 10%,@ 120V≤ 10%
	Standby power	@230V≤0.5W, dim off
	No-load Power Consumption	≤ 1W
	Inrush Current :	≤ 80A/400us @ 120W ≤ 80A/400us @ 160W ≤ 100A/400us @ 200W ≤ 100A/400us @ 240W ≤ 100A/400us @ 300W

	Connected quantity of 16A Breaker	8pcs/type B ; 13pcs/type C @ 120W 8pcs/type B ; 13pcs/type C @ 160W 7pcs/type B ; 12pcs/type C @ 200W 7pcs/type B ; 12pcs/type C @ 240W 7pcs/type B ; 12pcs/type C @ 300W
Output	Current Accuracy	± 5%
	Toggle the ammeter Toggle the typical value of the ammeter @200Vdc potentiometer to fine tune the current 240W factory Settings in the L shift current is 920mA; 200W factory Settings in the L shift current is 770mA; 160W factory Settings in the L shift current is 615mA; 120W factory Settings in the L shift current is 460mA; Please refer to Note 2 for instructions on current regulation and current gear switch toggle of potentiometer.	300W: LOW@840mA;ADJ/IO@0.84- 1.4A MID @ 1200mA HIGA @ 1400mA 240W: LOW@840mA;ADJ/IO@0.84- 1.2A MID @ 1000mA HIGA @ 1200mA 200W: LOW@700mA;ADJ/IO@0.7-1.0A MID @850mA HIGA @ 1000mA 160W: LOW@500mA;ADJ/IO@0.5-0.8A MID @650mA HIGA @800mA 120W: LOW@400mA;ADJ/IO@0.4-0.6A MID @500mA HIGA @600mA
	Dual output	CW@Io.max NW@LED- 1/50%Io.mA; LED-2/50%Io.mA WW@Io.max
	Started Delay Time	@230V≤0.5S,@ 120V≤ 1S
	Current Ripple (< 120 Hz)	±5% (Imax-Imin) / (Imax+Imin)
	PstLM	≤ 1
	SVM	≤0.4
	12V auxiliary power supply	Output voltage: 11- 14V; Output current: 250mA.max
Protection	Short Circuit Protection	Auto Recovery
	Overload Protection	Auto Recovery
	No-load Protection	Auto Recovery
	Insulation voltage	I/P to PE , 1.5KVac/1min
	Insulation resistance	I/P to DIM>10M ohm @ 500VDC
	Leakage current	I/P to PE < 0.7mA
	Surge	L-N: 6KV(2Ω), L/N-PE: 6KV(12Ω)
Environment	Ta/Operation Temperature	-40 ... +50°C @120-277V
	Ts/Storage Temperature	-40 ... +85°C
	Tc/Enclosure Temperature	90 °C
	Humidity	10%....90%RH
	Atmosphere	86- 108KPa

Wire	Input Wire	VDE: H05RN-F 300/500V 3G1.0mm <sup>2</sup> $\Phi$ 7.4 $\pm$ 1mm AC-L /Brown ; AC-N /Blue; PE /yellow green L:300 $\pm$ 10mm ( 40 $\pm$ 4mm / 10 $\pm$ 1.5mm) UL: 3*18AWG $\Phi$ 7.8 $\pm$ 1mm AC-L black AC-N white ; PE green L:300 $\pm$ 10mm ( 40 $\pm$ 4mm / 10 $\pm$ 1.5mm)
	Output Wire	VDE: H05RN-F 300/500V 3G1.0mm <sup>2</sup> $\Phi$ 7.4 $\pm$ 1mm LED+ Brown ; LED- 1 Blue ; LED-2 black L:200 $\pm$ 10mm ( 40 $\pm$ 4mm/10 $\pm$ 1.5mm) UL: 3*18AWG $\Phi$ 7.8 $\pm$ 1mm LED+ Red ; LED- 1 black ; LED-2 pink L:200 $\pm$ 8mm (35 $\pm$ 4mm/10 $\pm$ 1.5mm)
	Dimmer Wire1	3*22AWG UL 21996 $\Phi$ 5 $\pm$ 0.5mm DIM+purple; DIM- pink; +12V black and white; L: 220 $\pm$ 8mm /(40 $\pm$ 4mm/10 $\pm$ 1.5mm)
	Dimmer Wire2	3*22AWG UL 21996 $\Phi$ 5 $\pm$ 0.5mm DIM+purple; DIM-pink; +12V black and white; L: 250 $\pm$ 8mm / (40 $\pm$ 4mm/10 $\pm$ 1.5mm)
Standards	Certification	CE,UL
	Safety Standards	EN61347-1:2015,EN61347-2-13:2014/A1:2017,EN62493:2015, AS/NZ SIEC61347.2. 13:2013, AS/NZS 61347. 1:2016 Inc A1,UL8750
	EMC Standards	EN55015:2013/A1:2015,EN61000-3-2:2014,EN61000-3-3:2013,EN61 547:2009
	Performance	EN62384
Others	RoHS	Complied to 2011/65/EU
	Life Time	50000h Tc=75 $^{\circ}$ C
	Warranty	5years,F.R. < 10000ppm
<p>Remark 1.All Parameters, if not specified, are measured at 230VAC/50Hz and 25<math>^{\circ}</math>C ambient temperature.</p> <p>2.LED Driver is a component of the luminaires, Luminaires and wire layout will affect the EMC, please check the EMC with end products again.</p> <p>3. Potentiometer current regulation and current gear switch toggle instructions:</p> <p>1 ) When the potentiometer is needed to adjust the current when the gear switch is shifted to L, the potentiometer can be adjusted in the nominal output current range;</p> <p>2 ) when the need to switch toggle to adjust the current potentiometer to the minimum value to achieve the toggle switch to H/M/L to reach the nominal output current value.</p>		

## 2. Dimming function

Reference		Minimum Value	Typical Value	Maximum Value	Notes
0- 10V dimming	Maximum Applied Voltage	0V	12V	15V	
	Dimming Output Range	0%Io		100%Io	
	Suggested Dimming Voltage	0V		10V	
PWM dimming	PWM High Level	9V		10V	
	PWM Low Level	0V		0.3V	
	PWM Frequency Segment	1KHz		2KHz	
	PWM Duty Cycle	0%		99%	
Resistance dimming	Resistance Value	0 KΩ		100 KΩ	
	DIM Line output current		100uA		
	Dimming Output Range	0%Io		100%Io	

## 3. Dimming Operation

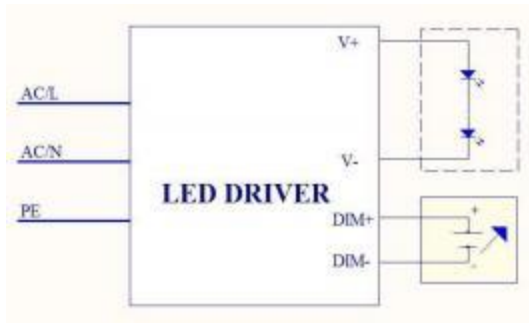

- ❖ Connect 0-10V Direct Voltage or 10V PWM1KHz signal between DIM+ and DIM- to adjust the output constant current values.
- ❖ Don't connect "DIM-" and "V-". The dimmer port can withstand a maximum voltage of 12V. If the external voltage exceeds 12V or the signal cable is reversed, the power supply may be damaged.

- Output current values (Typical Values) of 0- 10V Dimming adjustment.

Applied Dimming Voltage	0V	1V	2V	3V	4V	5V	6V	7V	8V	9V	10V	OPEN
Output Current Percentage	0%	10%	21%	32%	44%	55%	66%	77%	88%	100%	100%	100%

- Output current values (Typical Values) of PWM Dimming adjustment. Frequency Range: 1 KHz-2 KHz.

Duty Cycle	0%	10%	20%	30%	40%	50%	60%	70%	80%	90%	100%	OPEN
Output Current Percentage	0%	10%	21%	32%	44%	55%	66%	77%	88%	100%	100%	100%

- Output current values (Typical Values) of Resistance Dimming adjustment. Resistance Range: 0- 100K $\Omega$  .

Resistance Value	0K $\Omega$	10K $\Omega$	20K $\Omega$	30K $\Omega$	40K $\Omega$	50K $\Omega$	60K $\Omega$	70K $\Omega$	80K $\Omega$	90K $\Omega$	100K $\Omega$	OPEN
Output Current Percentage	0%	10%	21%	32%	44%	55%	66%	77%	88%	100%	100%	100%

- Dimming curve

0-10V dimming curve 0-10V

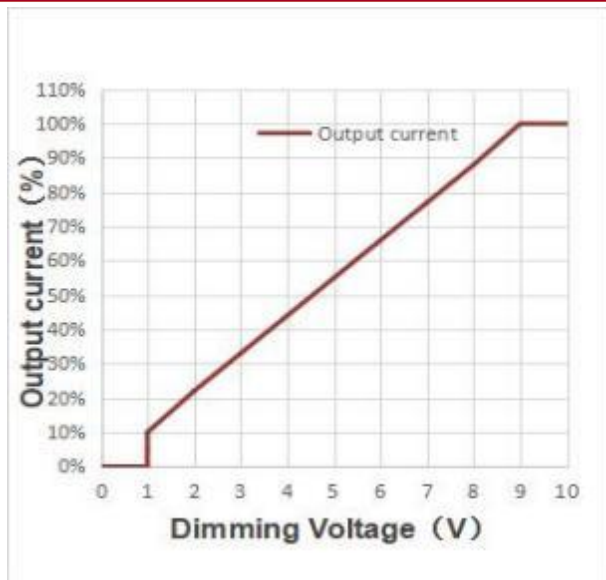

PWM dimming curve PWM

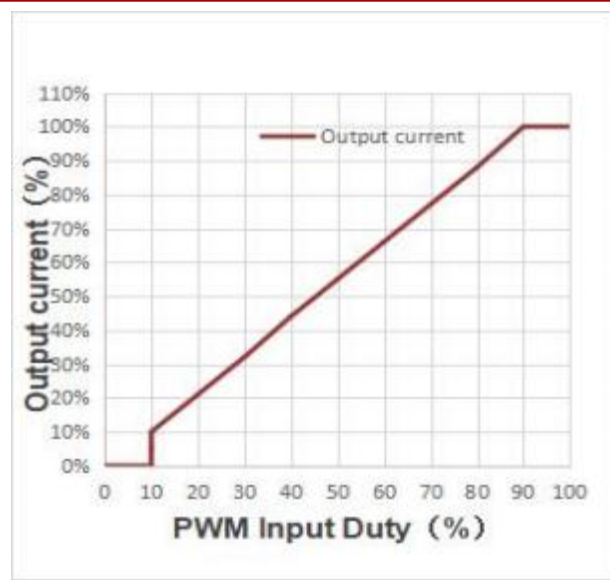

Resistance dimming curve

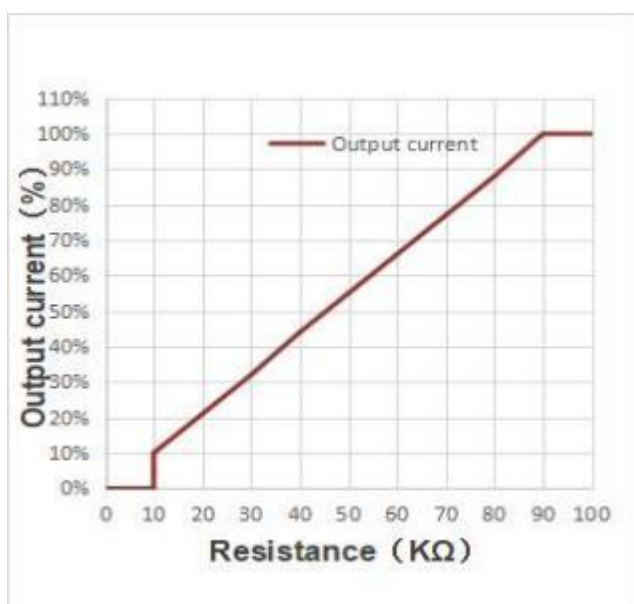

- Characteristic curve

**Output power Vs. input voltage  
(ring temperature 50 °C)**

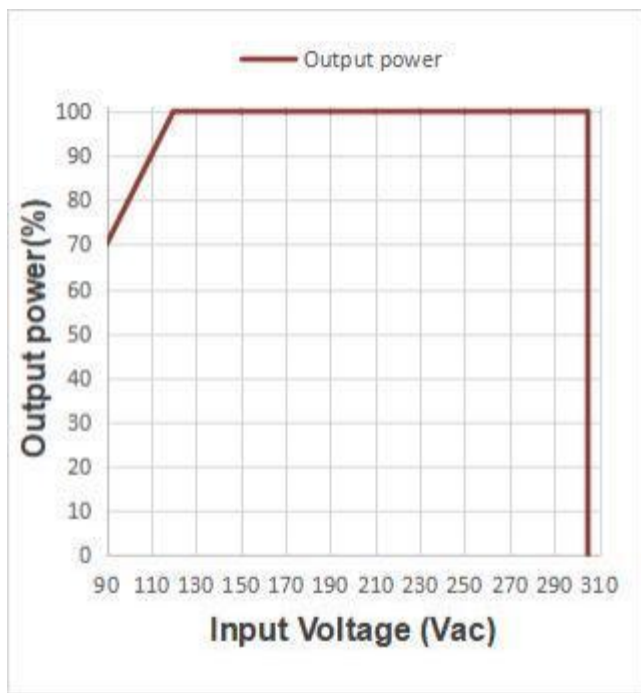

**Life Vs. shell temperature**

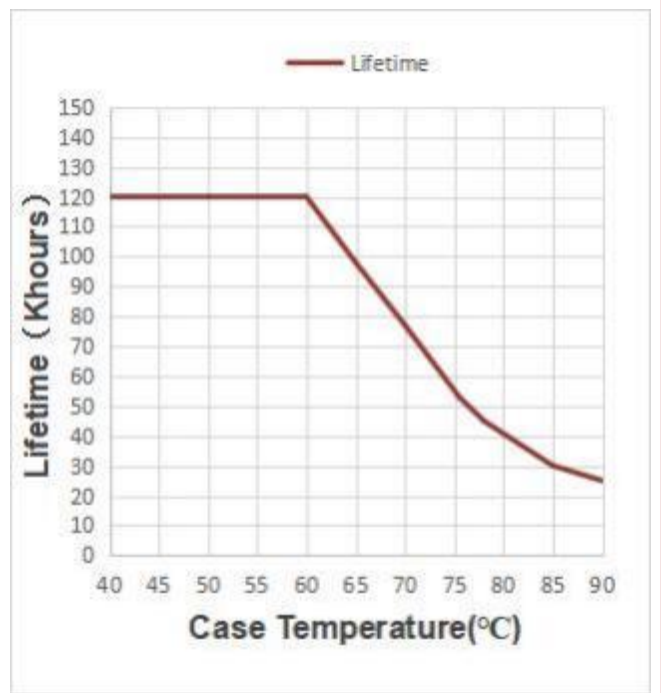

**Output power Vs. shell temperature**

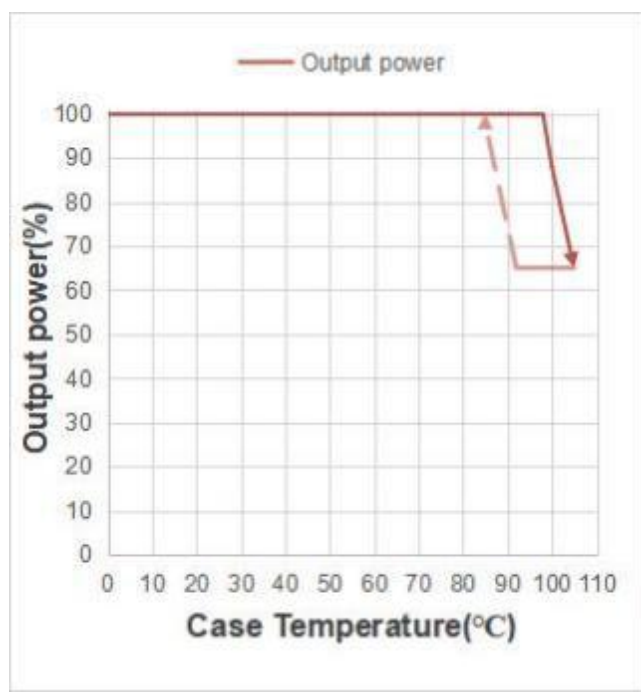

## 4. Dimension (Unit: mm)

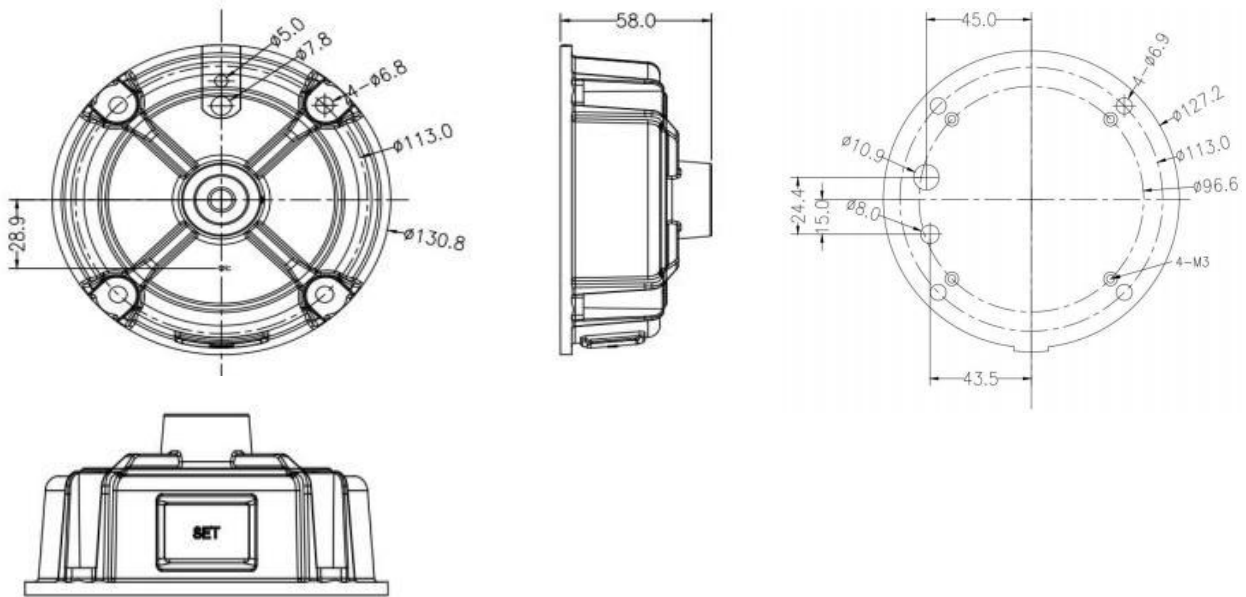

## 5. Packing information

Carton L*W*H(mm)	Pcs/Carton	Net weight/ Pcs(kg)	Net weight/ Carton(kg)	Gross weight / Carton(kg)
490*385*155	10	0.86	8.6	9.7

## 6. Wiring Diagram

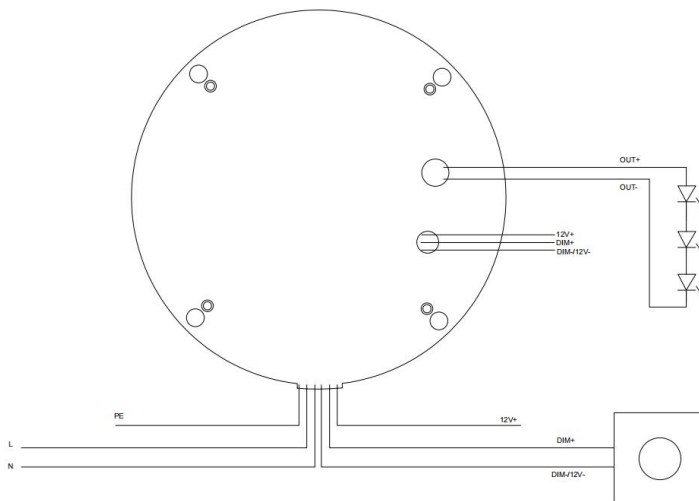

## 7. Wiring instructions

- All connections must be kept as short as possible to ensure good EMI behaviour
- Mains leads should be kept apart from LED Driver and other leads (ideally 5 – 10 cm distance)
- Advice the maximum length of output wires is 3 m
- Secondary switching is not permitted (Except for constant voltage)
- Incorrect wiring can damage LED modules.
- The wiring must be protected against short circuits to earth (sharp edged metals parts, metal cable clips, louver, etc.)

## 8. Schematic diagram of dimming end outlet

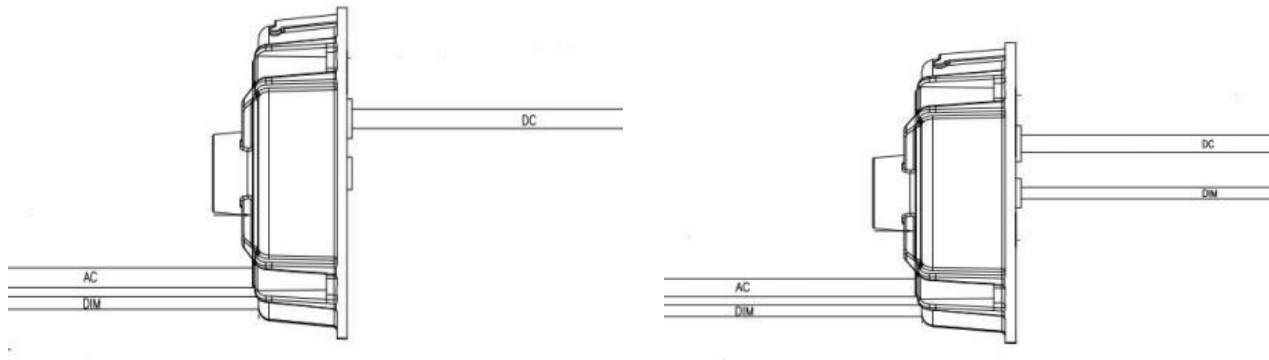

Dimmer Wire1

Dimmer Wire 2

### Warm tips:

1. It is recommended that LED beads be arranged first and then in a string.
- 2 external adjustable potentiometer and toggle switch, please after the operation, it is recommended to use 704 silicone waterproof glue seal.
- 3 LED lamp beads and aluminum substrate pressure to > 3KV.
4. The safety creepage distance between the aluminum substrate wiring and the edge of the plate  $\geq 5\text{mm}$ .
5. Bead wiring on the aluminum substrate reduces the copper laying area, reduces junction capacitance and reduces leakage current.
6. No residual dimming version description: When the dimming signal of the model S plate is 0V, the power supply has no output, and there will be junction capacitance between the copper foil of the aluminum base plate of the lamp and the ground wire, which will cause the lamp bead to appear slightly bright. It is necessary to add a resistor to each bead string and match the resistance value according to the parameters of the aluminum base plate and the lamp bead (typical value:  $5\text{K}\Omega \pm 1\text{K}\Omega$ ).

## 9. REVISION HISTORY

DATE	REV	Modification details
2024-05-30	V1.0	Initial release.