



Constant Current Driver

Model: XC100W700CG NS
XC150W700CG NS
XC200W700CG NS



Model	Output Current	Input Current	Input Power	Output Power Range	PF	Efficiency (*Typical)	Output Voltage	No load Voltage
XC100W700CG NS	700mA	0.48A ±10%	107W ±10%	100W ±5%	≥0.95	≥93%	100-143V	<190V
XC150W700CG NS	700mA	0.71A ±10%	160W ±10%	150W ±5%	≥0.95	≥94%	150-215V	<290V
XC200W700CG NS	700mA	0.93A ±10%	210W ±10%	200W ±5%	≥0.95	≥94%	200-285V	<350V

* Test result @230V, 50Hz, Full Load.

1. Parameters

Category	Item	Technical Norm
Features	Output Type	Constant Current
	Output Features	Non-Isolation
	IP Grade	IP67
	Insulation Class	Class II
Input	Rated Input Voltage	220-240VAC
	Range of Input Voltage	198-264VAC
	Frequency	50/60Hz
	Input Current	≤0.53A @100W (230VAC, full load) ≤0.78A @150W (230VAC, full load) ≤1.03A @200W (230VAC, full load)
	Input Power	≤118W @100W (230VAC, full load) ≤176W @150W (230VAC, full load) ≤231W @200W (230VAC, full load)
	Power Factor	≥0.95 (230VAC, full load)
	THD	≤15% (230VAC, full load)
	Inrush Current	≤60A/200us (230VAC, full load)
Output	Output Voltage Range	100-143VDC @100W 150-215VDC @150W 200-285VDC @200W
	No Load Voltage	190VDC Max. @100W 290VDC Max. @150W 350VDC Max. @200W
	Output Current	700mA
	Max. Output Power	100W 150W 200W
	Efficiency	≥93% @100W (230VAC, full load) ≥94% @150W&200W (230VAC, full load)

	Current Ripple(< 120 Hz)	$\pm 5\%$ (Imax-Imin)/(Imax+Imin)
	PstLM	≤ 1
	SVM	≤ 0.4
	Current Accuracy	$\pm 5\%$
	Line Regulation	$\pm 5\%$
	Load Regulation	$\pm 5\%$
	Started Delay Time	$\leq 0.5S(230VAC, \text{ full load})$
Protection	Short Circuit Protection	Auto Recovery
	Overload Protection	Auto Recovery
	No-load Protection	Auto Recovery
	Insulation voltage	1500V 5mA 60S between I/P to PE, O/P to PE
	Insulation resistance	>100M ohm @ 500VDC
	Leakage current	I/P to O/P <0.7mA
Environment	Ta/Operation Temperature	-40....+50°C
	Ts/Storage Temperature	-40....+85°C
	Tc/Enclosure Temperature	+90 °C
	Humidity	10%....93%RH
	Atmosphere	86-108KPa
Construction	Connection Method	Cable
	Installation	Independent
	PRI Wire preparation	3*1.0mm ² /1000mm
	SEC Wire preparation	2*0.75mm ² /300mm
	Dimension	126*41*29mm (L*W*H) @100W , 150W 143*49*33mm (L*W*H) @200W
Standards	Certification	CE EMC
	Safety Standards	EN 61347-1:2015/A1:2021 EN 61347-2-13:2014/A1:2017 EN IEC 62384:2020 EN 62493:2015 AS61347.2.13:2018 AS/NZS61347.1:2016 Inc A1 BS EN 61347-1:2015/A1:2021 BS EN 61347-2-13:2014/A1:2017 BS EN 62493:2015 BS EN IEC 62384:2020
	EMC Standards	EN IEC 55015:2019 EN IEC 55015:2019/A11:2020 EN IEC 61000-3-2:2019/A1:2021 EN 61000-3-3:2013/A2:2021 EN 61547:2009
	Performance	EN62384:2020
	Surge	L - N / 6kV ; L/N - PE / 6kV
	Others	
Others	RoHS	Complied to 2011/65/EU
	REACH	EU Regulation (EC) No 1907/2006
	Life Time	50000h @Ta/ Tc
	Warranty	5years ,F.R. < 10000ppm
	Noise	$\leq 24dB$ @Background noise $\leq 18dB$,Interval $\geq 15cm$

Remark:

1. All Parameters, if not specified, are measured at 230VAC/50Hz and 25°C ambient temperature.
2. LED Driver is a component of the luminaires, Luminaires and wire layout will affect the EMC, please check the EMC with end products again.
3. Do not install upside down.

2. Connected quantities of different current Breaker

TYPE	Connected quantities of different current Breaker						Input Voltage	Inrush Current /A	Time
	current (A)	10	13	16	20	25			
	Installation wire diameter	1.5mm ²	2.5mm ²	2.5mm ²	4mm ²	4mm ²			
TYPE B		10	13	16	20	25	@230VAC	60	200us
TYPE C		16	21	26	32	40			
TYPE D		26	33	41	51	64			

3. Label

XC100W700CG NS

INPUT	KGP LED Driver	OUTPUT
<ul style="list-style-type: none"> • ACL BN • ACN BU ⊕ GN/YR 	<small>KGP Electronics GmbH Hueckstraße 19 DE-58511 Lüdenscheid</small> MODEL:XC100W700CG NS INPUT:220-240V~Max.0.53A 50/60Hz PF≥0.95 OUTPUT:100-143V=0.7A Uout:Max.190VDC 100W Suitable for Dry, Damp and Wet Locations. For LED Module only ta:50°C tc:90°C CE SELV IP67	<ul style="list-style-type: none"> Vo+RD • Vo- BK •

XC150W700CG NS

INPUT	KGP LED Driver	OUTPUT
<ul style="list-style-type: none"> • ACL BN • ACN BU ⊕ GN/YR 	<small>KGP Electronics GmbH Hueckstraße 19 DE-58511 Lüdenscheid</small> MODEL:XC150W700CG NS INPUT:220-240V~Max.0.78A 50/60Hz PF≥0.95 OUTPUT:150-215V=0.7A Uout:Max.290VDC 150W Suitable for Dry, Damp and Wet Locations. For LED Module only ta:50°C tc:90°C CE SELV IP67	<ul style="list-style-type: none"> Vo+RD • Vo- BK •

XC200W700CG NS

INPUT	KGP LED Driver	OUTPUT
<ul style="list-style-type: none"> • ACL BN • ACN BU ⊕ GN/YR 	<small>KGP Electronics GmbH Hueckstraße 19 DE-58511 Lüdenscheid</small> MODEL:XC200W700CG NS INPUT:220-240V~Max.1.03A 50/60Hz PF≥0.95 OUTPUT:200-285V=0.7A Uout:Max.350VDC 200W Suitable for Dry, Damp and Wet Locations. For LED Module only ta:50°C tc:90°C CE SELV IP67	<ul style="list-style-type: none"> Vo+RD • Vo- BK •

4. Electrical values

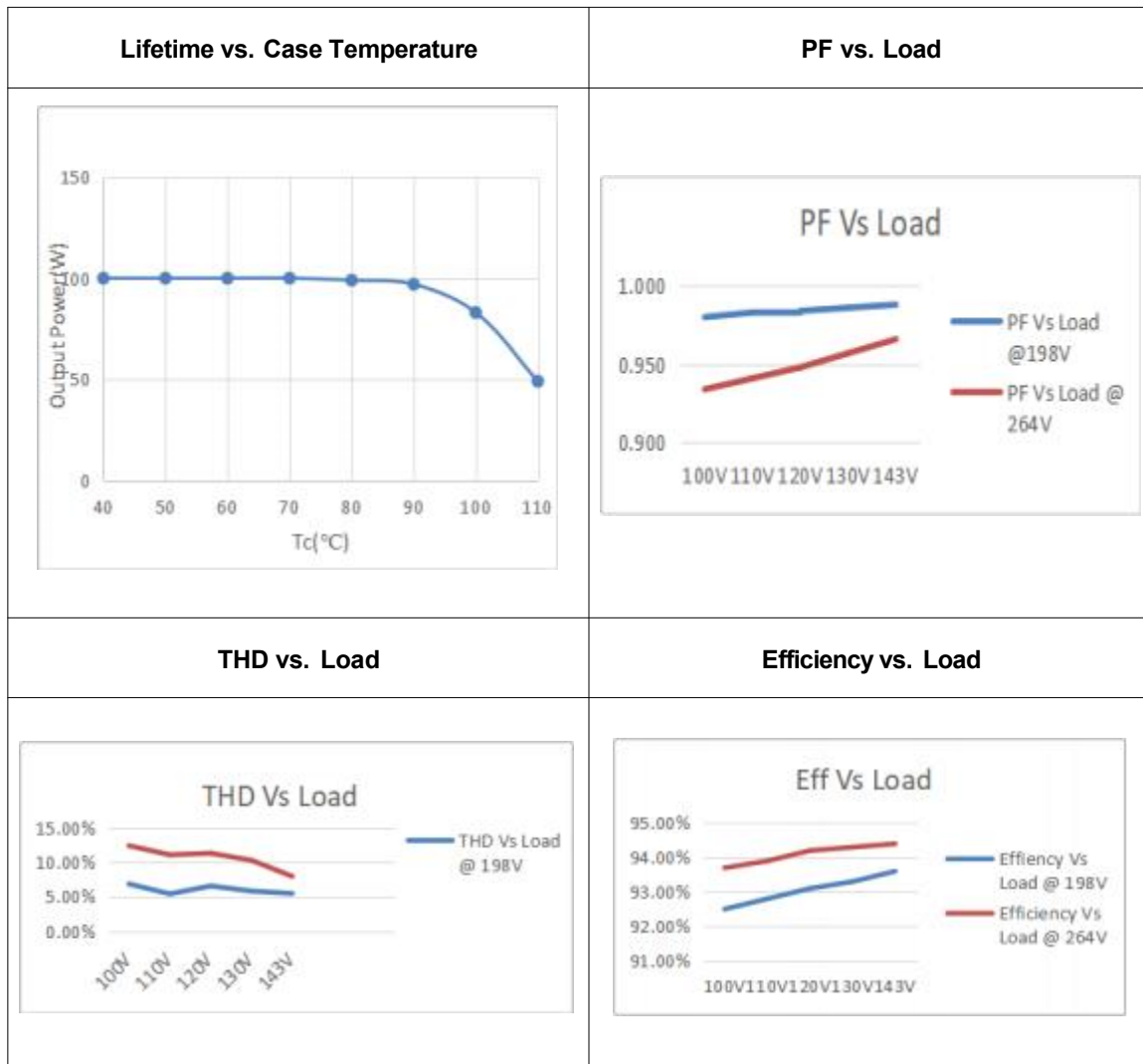

5. Dimension (Unit: mm)

XC100W700CG NS & XC150W700CG NS

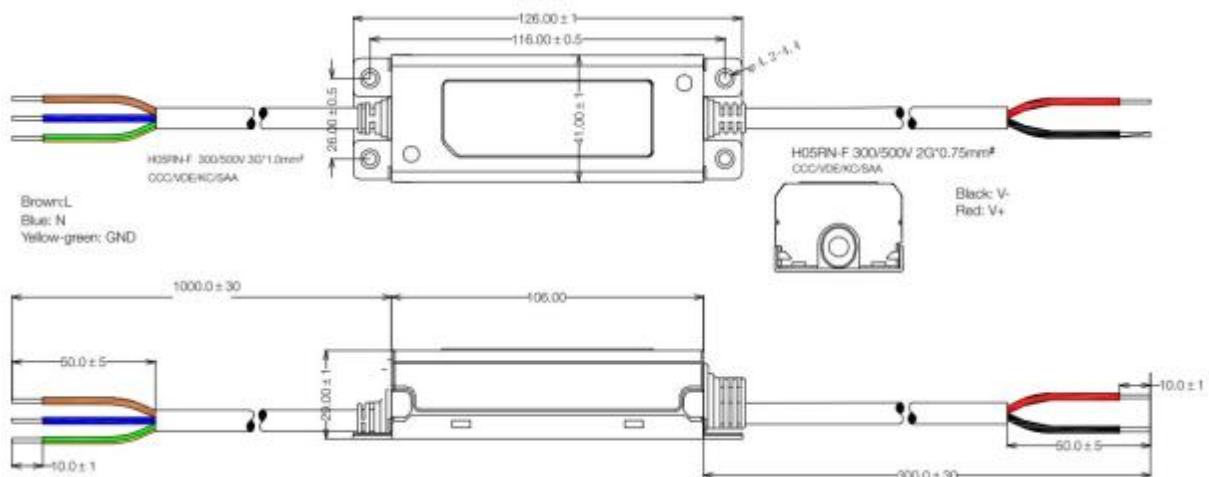

XC200W700CG NS

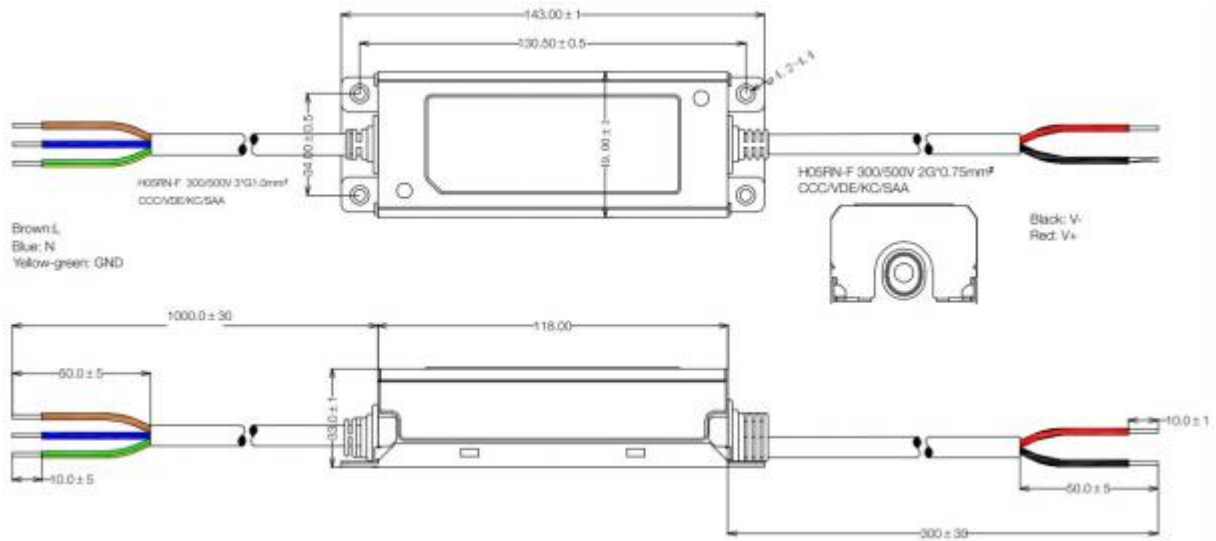

6. Wiring Diagram

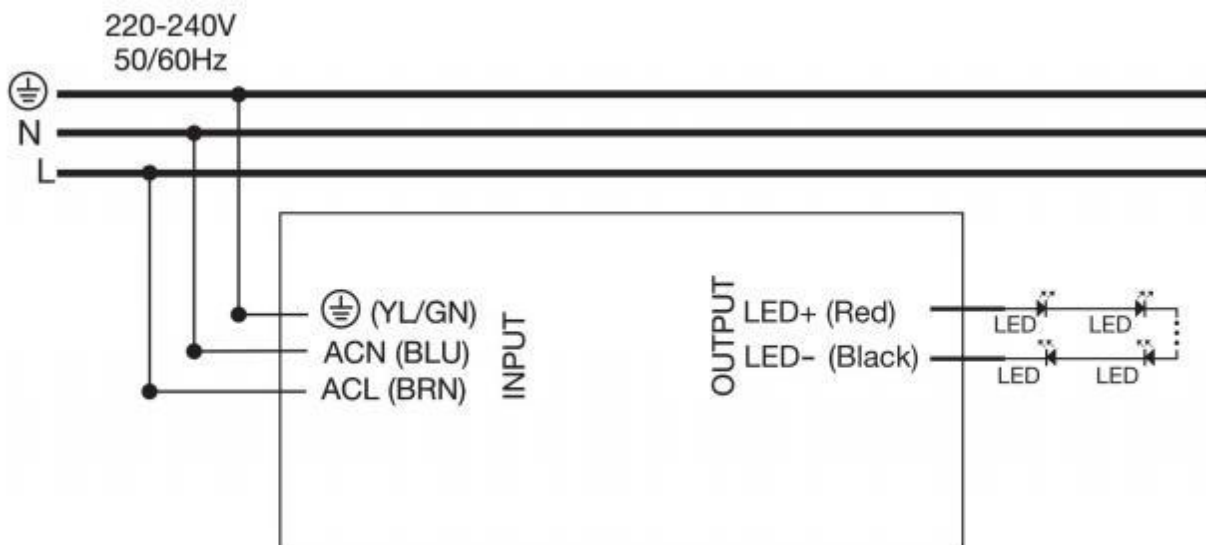

7. Packing information

Packing way	Model	Carton L*W*H(mm)	Pcs/ Carton	Net weight/ Pcs(kg)	Net weight/ Carton(kg)	Gross weight/ Carton(kg)
Industrial	XC100W700CG NS	335*320*165mm	32	0.315	10.08	11.06
	XC150W700CG NS	335*320*165mm	32	0.315	10.08	11.07
	XC200W700CG NS	385*255*225mm	30	0.443	13.29	14.44

8. Wiring instructions

- All connections must be kept as short as possible to ensure good EMI behaviour
- Mains leads should be kept apart from LED Driver and other leads (ideally 5 – 10 cm distance)
- Advice the maximum length of output wires is 0.5 m
- Secondary switching is not permitted (Except for constant voltage)
- Incorrect wiring can damage LED modules.
- The wiring must be protected against short circuits to earth (sharp edged metals parts, metal cable clips, louver, etc.)
- Hot plug-in is not supported due to residual output voltage of > 0 V up to mains voltage. Danger to life.
- When connecting an LED load, restart the device to activate the LED output.
- This can be done via mains reset or via interface (DALI, DSI, switch DIM).

9. Replace LED module

- Mains off
- Remove LED module
- Wait for 30 seconds
- Connect LED module again
- Hot plug-in or secondary switching of LEDs is not permitted and may cause a very high current to the LEDs

10. REVISION HISTORY

DATE	REV	Modification details
2024-11-20	V1.0	Initial release.
2025-7-29	V1.1	modificationTHD和Ta