



Constant Current Driver

Model:XC50W530-1400
 XC50W1450-2100
 XC75W700-1050
 XC75W1300-2100
 XC100W700-1050
 XC100W1750-2780
 XC150W500-1150
 XC150W1800-4200



Model	Output Current	Input Current	Input Power	Output Power Range	PF	Efficiency (*Typical)	Output Voltage	No load Voltage
XC50W530-1400	1400mA	≤0.30A	56W	11.7-50W	0.95	89%	22~54V	64V
XC50W1450-2100	2100mA	≤0.30A	56W	31.9-50W	0.95	88%	22~34V	46V
XC75W700-1050	1050mA	≤0.45A	89W	37-75W	0.95	91%	53~107V	119V
XC75W1300-2100	2100mA	≤0.45A	89W	35-75W	0.95	89%	27-56V	64V
XC100W700-1050	1050mA	≤0.60A	115W	49.7-100W	0.95	91%	71-142V	155V
XC100W1750-2780	2780mA	≤0.60A	115W	47.25-100W	0.95	90%	27-56V	64V
XC150W500-1150	1150mA	≤0.80A	175W	47.5-150W	0.95	91%	95-214V	250V
XC150W1800-4200	4200mA	≤0.80A	175W	45-150W	0.95	90%	25-56V	64V

* Test result @230V, 50Hz, Full Load.

* The efficiencies were all tested under steady state

1. Parameters

Category	Item	Technical Norm
Features	Output Type	Constant Current
	Output Features	Isolation
	IP Grade	IP67
	Insulation Class	Class I
Input	Rated Input Voltage	100-277VAC
	Range of Input Voltage	100-305VAC or 142-431VDC
	Frequency	50-60Hz
	Input Current	≤0.30A @50W(230VAC, full load) ≤0.45A @75W(230VAC, full load) ≤0.60A @100W(230VAC, full load) ≤0.80A @150W(230VAC, full load)
	Input Power	≤56W @50W(230VAC, full load) ≤89W @75W(230VAC, full load) ≤115W @100W(230VAC, full load) ≤175W @150W(230VAC, full load)
	Power Factor	≥0.95 (230VAC, full load)
	THD	≤10% (230VAC, full load)

	No-load Power Consumption	/
Output	Output Voltage Range	22-54VDC@XC50W530-1400 22-34VDC@XC50W1450-2100 53-107VDC@XC75W700-1050 27-56VDC@XC75W1300-2100 71-142VDC@XC100W700-1050 27-56VDC@XC100W1750-2780 95-214VDC@XC150W500-1150 25-56VDC@XC150W1800-4200
	No Load Voltage	64VDC Max.@XC50W530-1400 46VDC Max.@XC50W1450-2100 119VDC Max.@XC75W700-1050 64VDC Max.@XC75W1300-2100 155VDC Max.@XC100W700-1050 64VDC Max.@XC100W1750-2780 250VDC Max.@XC150W500-1150 64VDC Max.@XC150W1800-4200
	Output Current	530-1400mA @XC50W530-1400(adjustable) 1450-2100mA @XC50W1450-2100(adjustable) 700-1050mA @XC75W700-1050(adjustable) 1300-2100mA @XC75W1300-2100(adjustable) 700-1050mA@XC100W700-1050(adjustable) 1750-2780mA@XC100W1750-2780(adjustable) 500-1150mA@XC150W500-1150(adjustable) 1800-4200mA@XC150W1800-4200(adjustable)
	Max. Output Power	50W@XC50W530-1400 50W@XC50W1450-2100 75W@XC75W700-1050 75W@XC75W1300-2100 100W@XC100W700-1050 100W@XC100W1750-2780 150W@XC150W500-1150 150W@XC150W1800-4200
	Efficiency	≥89%@XC50W530-1400(230VAC, full load) ≥88%@XC50W1450-2100(230VAC, full load) ≥91%@XC75W700-1050(230VAC, full load) ≥89%@XC75W1300-2100(230VAC, full load) ≥91%@XC100W700-1050(230VAC, full load) ≥90%@XC100W1750-2780(230VAC, full load) ≥91%@XC150W500-1150 3IN1 (230VAC, full load) ≥90%@XC150W1800-4200 3IN1 (230VAC, full load)
	Current Ripple(< 120 Hz)	±5%
	PstLM	≤1
	SVM	≤0.4

	Current Accuracy	±5%
	Line Regulation	±5%
	Load Regulation	±5%
	Started Delay Time	≤0.5S(230VAC, full load) ≤1.2S(115VAC, full load)
Protection	Short Circuit Protection	Auto Recovery
	Over-temperature protection	When the TC point temperature of the casing exceeds 90℃, it switches to a current reduction mode, and the current automatically resumes once the over-temperature is cleared.
	AC Over Voltage Protection	320-380Vac (When the input voltage exceeds the protection voltage, the output voltage will be shut off, and it can automatically recover after the abnormal input condition is removed)
	AC Under Voltage protection	75-85Vac (When the input voltage falls below the protection voltage, the output voltage will be cut off and can automatically recover after the abnormal input condition is removed)
	Output overload protection	Protection mode:Flicker restart mode, can automatically recover after abnormal conditions are removed
	No-load Protection	Auto Recovery
	Insulation voltage	I/P-O/P: 3750Vac/5mA/60S I/P-FG: 1800Vac/5mA/60S O/P-FG: 1500Vac/5mA/60S
	Insulation resistance	>100M ohm @ 500VDC/+25℃/70%RH
	Leakage current	I/P-FG: <0.75mA
Environment	Ta/Operation Temperature	-40....+50℃@Vin100-200V -40....+60℃@Vin200-277V
	Ts/Storage Temperature	-40....+85℃
	Tc/Enclosure Temperature	+90℃
	Humidity	10%....90%RH
	Atmosphere	86-108KPa
Construction	Connection Method	Cable
	Installation	Independent
	PRI Wire preparation	3*0.75mm ² /290mm
	SEC Wire preparation	2*0.75mm ² /290mm
	Dimension	143*49*33mm (L*W*H)@50W,75W 164*53*33mm (L*W*H)@100W 186*60*38mm (L*W*H)@150W
Standards	Certification	CE
	Safety Standards	EN 61347-1:2015/A1:2021 EN 61347-2-13:2014/A1:2017

		EN IEC 62384:2020 EN 62493:2015 AS61347.2.13:2018 AS/NZS61347.1:2016 Inc A1 BS EN 61347-1:2015/A1:2021 BS EN 61347-2-13:2014/A1:2017 BS EN 62493:2015 BS EN IEC 62384:2020
	EMC Standards	EN IEC 55015:2019 EN IEC 55015:2019/A11:2020 EN IEC 61000-3-2:2019/A1:2021 EN 61000-3-3:2013/A2:2021 EN 61547:2009
	Performance	EN62384:2020
	Surge	L-N/:6kV @50W,75W,100W,150W L/N-Earth:6kV @50W L/N-Earth:10kV @75W,100W,150W
Others	RoHS	complied to 2011/65/EU
	REACH	EU Regulation (EC) No 1907/2006
	Life Time	50000h @Tc<+80°C
	Warranty	5years ,F.R. < 100ppm
	Noise	≤ 24dB @Background noise ≤15dB ,Interval≥20cm

Remark:

1. All Parameters, if not specified, are measured at 230VAC/50Hz and 25°C ambient temperature.
2. LED Driver is a component of the luminaires, Luminaires and wire layout will affect the EMC, please check the EMC with end products again.
3. Do not install upside down.

2. Connected quantities of different current Breaker

XC50W530-1400&XC50W1450-2100

TYPE	Connected quantities of different current Breaker						Input Voltage (V)	Inrush Current(A)	Time (μs)
	current (A)	10	13	16	20	25			
	Installation wire diameter	1.5mm ²	2.5mm ²	2.5mm ²	4mm ²	4mm ²			
TYPE B	11	14	17	22	27	@230VAC	55	200	
TYPE C	17	23	28	35	44				
TYPE D	28	36	45	56	70				

XC75W700-1050&XC75W1300-2100

TYPE	Connected quantities of different current Breaker						Input Voltage (V)	Inrush Current(A)	Time (μs)
	current (A)	10	13	16	20	25			
	Installation wire diameter	1.5mm ²	2.5mm ²	2.5mm ²	4mm ²	4mm ²			
TYPE B	9	12	15	18	23	@230VAC	65	200	
TYPE C	15	19	24	30	37				
TYPE D	24	31	38	47	59				

XC100W700-1050&XC100W1750-2780

TYPE	Connected quantities of different current Breaker						Input Voltage (V)	Inrush Current(A)	Time (μs)
	current (A)	10	13	16	20	25			
	Installation wire diameter	1.5mm ²	2.5mm ²	2.5mm ²	4mm ²	4mm ²			
TYPE B	8	10	13	16	20	@230VAC	75	200	
TYPE C	13	17	20	26	32				
TYPE D	20	27	33	41	51				

XC150W500-1150&XC150W1800-4200

TYPE	Connected quantities of different current Breaker						Input Voltage (V)	Inrush Current(A)	Time (μs)
	current (A)	10	13	16	20	25			
	Installation wire diameter	1.5mm ²	2.5mm ²	2.5mm ²	4mm ²	4mm ²			
TYPE B	7	9	11	14	18	@230VAC	85	200	
TYPE C	11	15	18	23	28				
TYPE D	18	23	29	36	45				

3. Label

XC50W530-1400

INPUT	KGP LED Driver MODEL:XC50W530-1400	OUTPUT
<ul style="list-style-type: none"> • ACL BN • ACN BU ⊕ GN/YR 	<p>INPUT:100-277V~Max.0.6A 50/60Hz PF\geq0.95 OUTPUT:22-54V = 0.53-1.4A Uout:Max.64VDC Max.50W Suitable for Dry, Damp and Wet Locations. Constant Current Type for LED Only ta:50°C@Vin100-200V ta:60°C@Vin200-277V tc:90°C</p>	<ul style="list-style-type: none"> Vo+BN • Vo- BU • Io ADJ.
<p>EAC CE UK CA SELV IP67 </p>		

XC50W1450-2100

INPUT	KGP LED Driver MODEL:XC50W1450-2100	OUTPUT
<ul style="list-style-type: none"> • ACL BN • ACN BU ⊕ GN/YR 	<p>INPUT:100-277V~Max.0.6A 50/60Hz PF\geq0.95 OUTPUT:22-34V=1.45-2.1A Uout:Max.46VDC Max.50W Suitable for Dry, Damp and Wet Locations. Constant Current Type for LED Only ta:50°C@Vin100-200V ta:60°C@Vin200-277V tc:90°C</p>	<ul style="list-style-type: none"> Vo+BN • Vo- BU • Io ADJ.
<p>EAC CE UK CA SELV IP67 </p>		

XC75W700-1050

INPUT	KGP LED Driver MODEL:XC75W700-1050	OUTPUT
<ul style="list-style-type: none"> • ACL BN • ACN BU ⊕ GN/YR 	<p>INPUT:100-277V~Max.1.0A 50/60Hz PF\geq0.95 OUTPUT:53-107V=0.7-1.05A Uout:Max.119VDC Max.75W Suitable for Dry, Damp and Wet Locations. Constant Current Type for LED Only ta:50°C@Vin100-200V ta:60°C@Vin200-277V tc:90°C</p>	<ul style="list-style-type: none"> Vo+BN • Vo- BU • Io ADJ.
<p>EAC CE UK CA SELV IP67 </p>		

XC75W1300-2100

INPUT	KGP LED Driver MODEL:XC75W1300-2100	OUTPUT
<ul style="list-style-type: none"> • ACL BN • ACN BU ⊕ GN/YR 	<p>INPUT:100-277V~Max.1.0A 50/60Hz PF\geq0.95 OUTPUT:27-56V=1.3-2.1A Uout:Max.64VDC Max.75W Suitable for Dry, Damp and Wet Locations. Constant Current Type for LED Only ta:50°C@Vin100-200V ta:60°C@Vin200-277V tc:90°C</p>	<ul style="list-style-type: none"> Vo+BN • Vo- BU • Io ADJ.
<p>EAC CE UK CA SELV IP67 </p>		

XC100W700-1050

INPUT	KGP LED Driver MODEL:XC100W700-1050	OUTPUT
<ul style="list-style-type: none"> • ACL BN • ACN BU ⊕ GN/YR 	<p>INPUT:100-277V~Max.1.1A 50/60Hz PF\geq0.95 OUTPUT:71-142V=0.7-1.05A Uout:Max.155VDC Max.100W Suitable for Dry, Damp and Wet Locations. Constant Current Type for LED Only ta:50°C@Vin100-200V ta:60°C@Vin200-277V tc:90°C</p> <p>UK EAC CE IP67</p>	<ul style="list-style-type: none"> Vo+BN Vo- BU Io ADJ.

XC100W1750-2780

INPUT	KGP LED Driver MODEL:XC100W1750-2780	OUTPUT
<ul style="list-style-type: none"> • ACL BN • ACN BU ⊕ GN/YR 	<p>INPUT:100-277V~Max.1.1A 50/60Hz PF\geq0.95 OUTPUT:27-56V=1.75-2.78A Uout:Max.64VDC Max.100W Suitable for Dry, Damp and Wet Locations. Constant Current Type for LED Only ta:50°C@Vin100-200V ta:60°C@Vin200-277V tc:90°C</p> <p>EAC CE UK SELV IP67</p>	<ul style="list-style-type: none"> Vo+BN Vo- BU Io ADJ.

XC150W500-1150

INPUT	KGP LED Driver MODEL:XC150W500-1150	OUTPUT
<ul style="list-style-type: none"> • ACL BN • ACN BU ⊕ GN/YR 	<p>INPUT:100-277V~Max.1.8A 50/60Hz PF\geq0.95 OUTPUT:95-214V=0.5-1.15A Uout:Max.150VDC Max.150W Suitable for Dry, Damp and Wet Locations. Constant Current Type for LED Only ta:50°C@Vin100-200V ta:60°C@Vin200-277V tc:90°C</p> <p>UK EAC CE IP67</p>	<ul style="list-style-type: none"> Vo+BN Vo- BU Io ADJ.

XC150W1800-4200

INPUT	KGP LED Driver MODEL:XC150W1800-4200	OUTPUT
<ul style="list-style-type: none"> • ACL BN • ACN BU ⊕ GN/YR 	<p>INPUT:100-277V~Max.1.8A 50/60Hz PF\geq0.95 OUTPUT:25-56V=1.8-4.2A Uout:Max.64VDC Max.150W Suitable for Dry, Damp and Wet Locations. Constant Current Type for LED Only ta:50°C@Vin100-200V ta:60°C@Vin200-277V tc:90°C</p> <p>UK EAC CE SELV IP67</p>	<ul style="list-style-type: none"> Vo+BN Vo- BU Io ADJ.

4. Electrical values

XC50W530-1400:

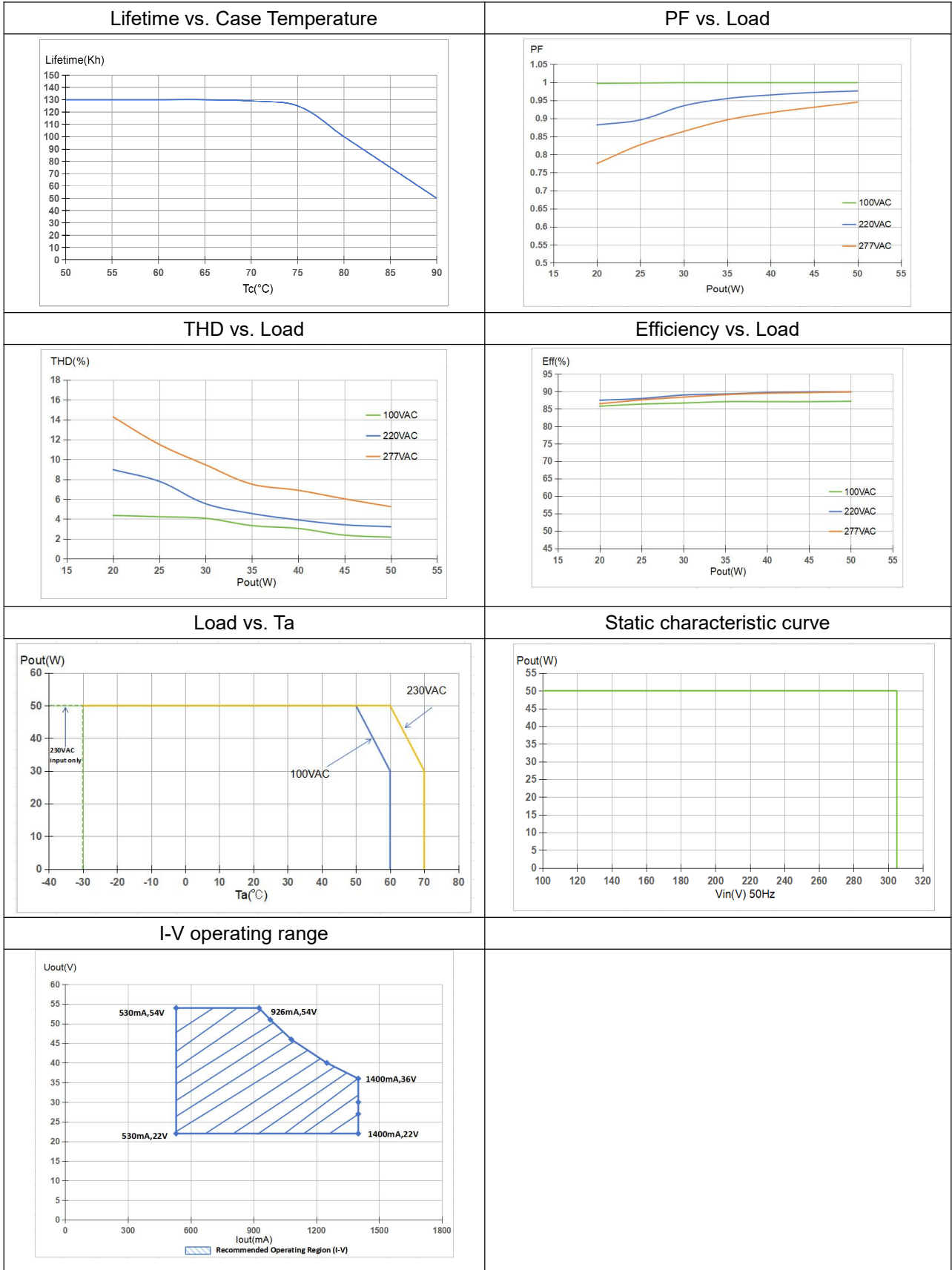

XC50W1450-2100:

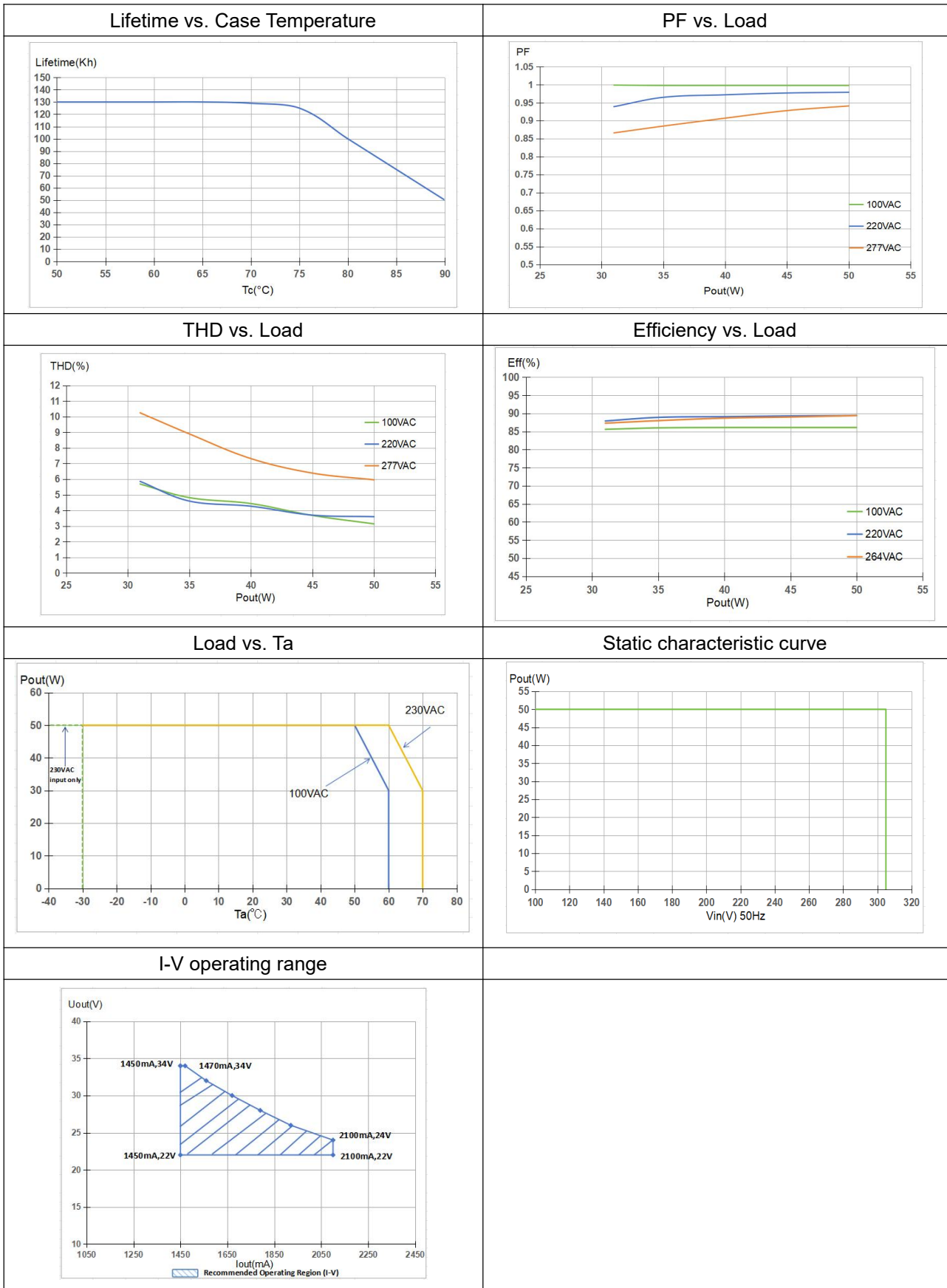

XC75W700-1050:

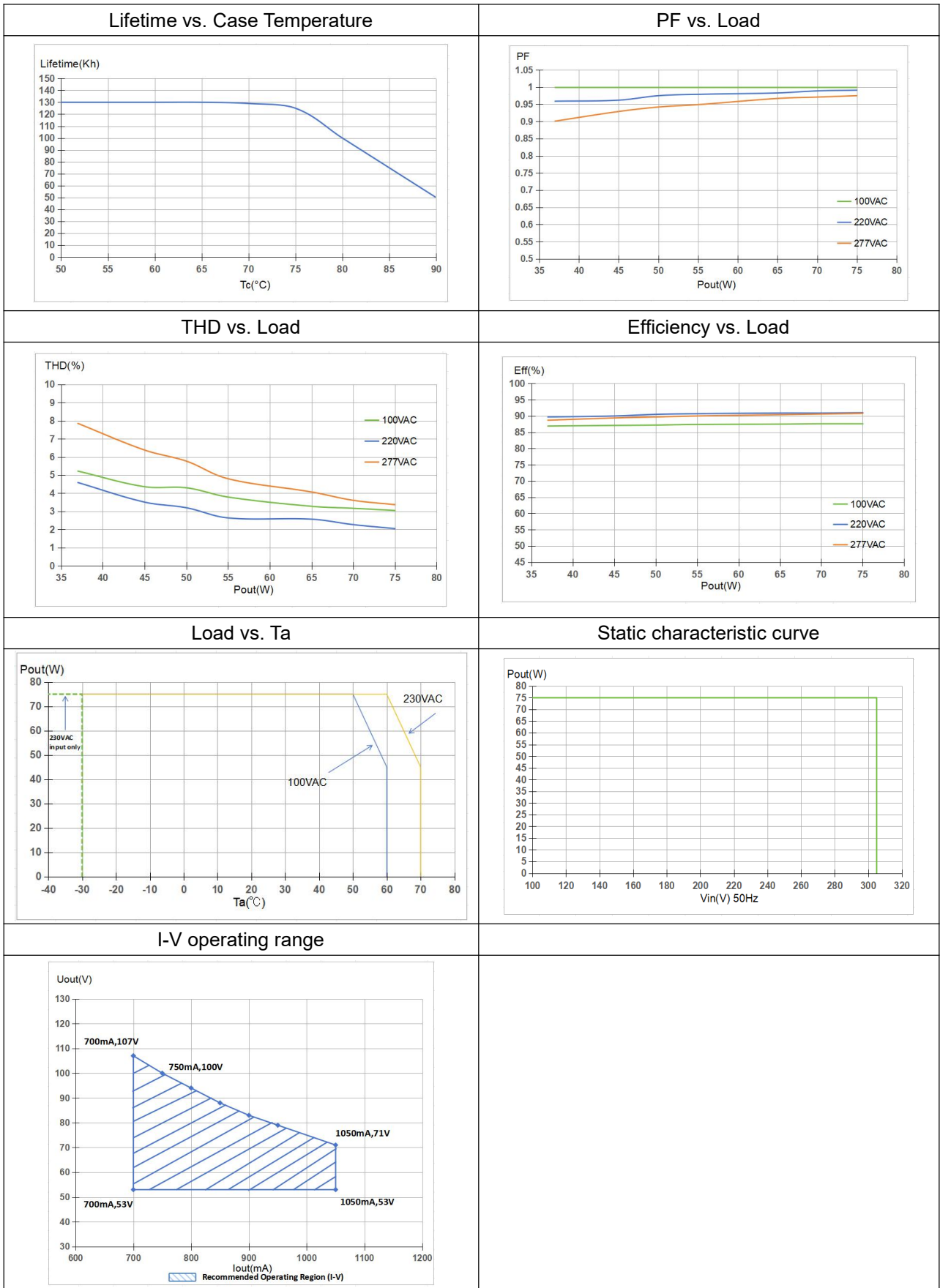

XC75W1300-2100:

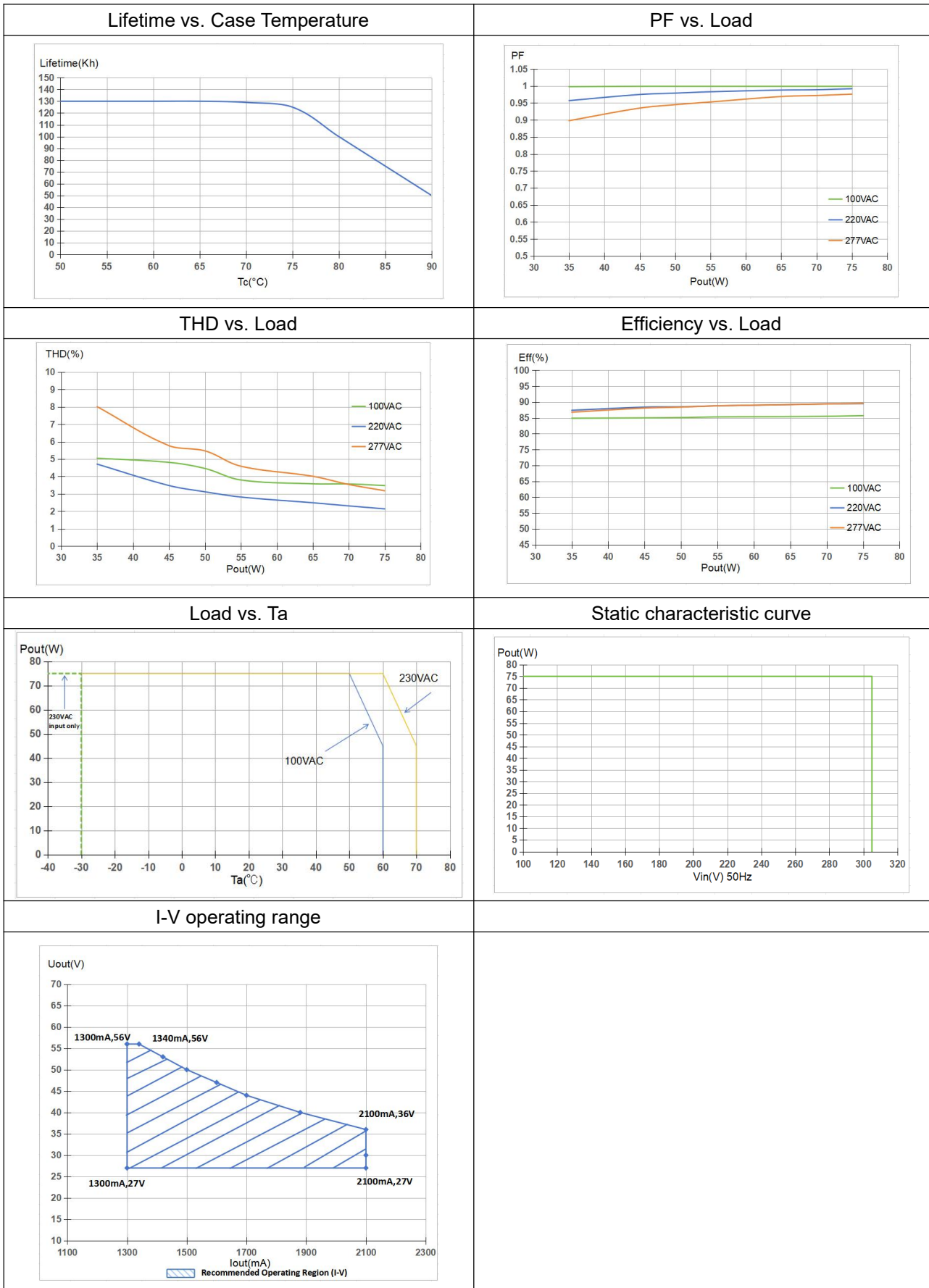

XC100W700-1050:

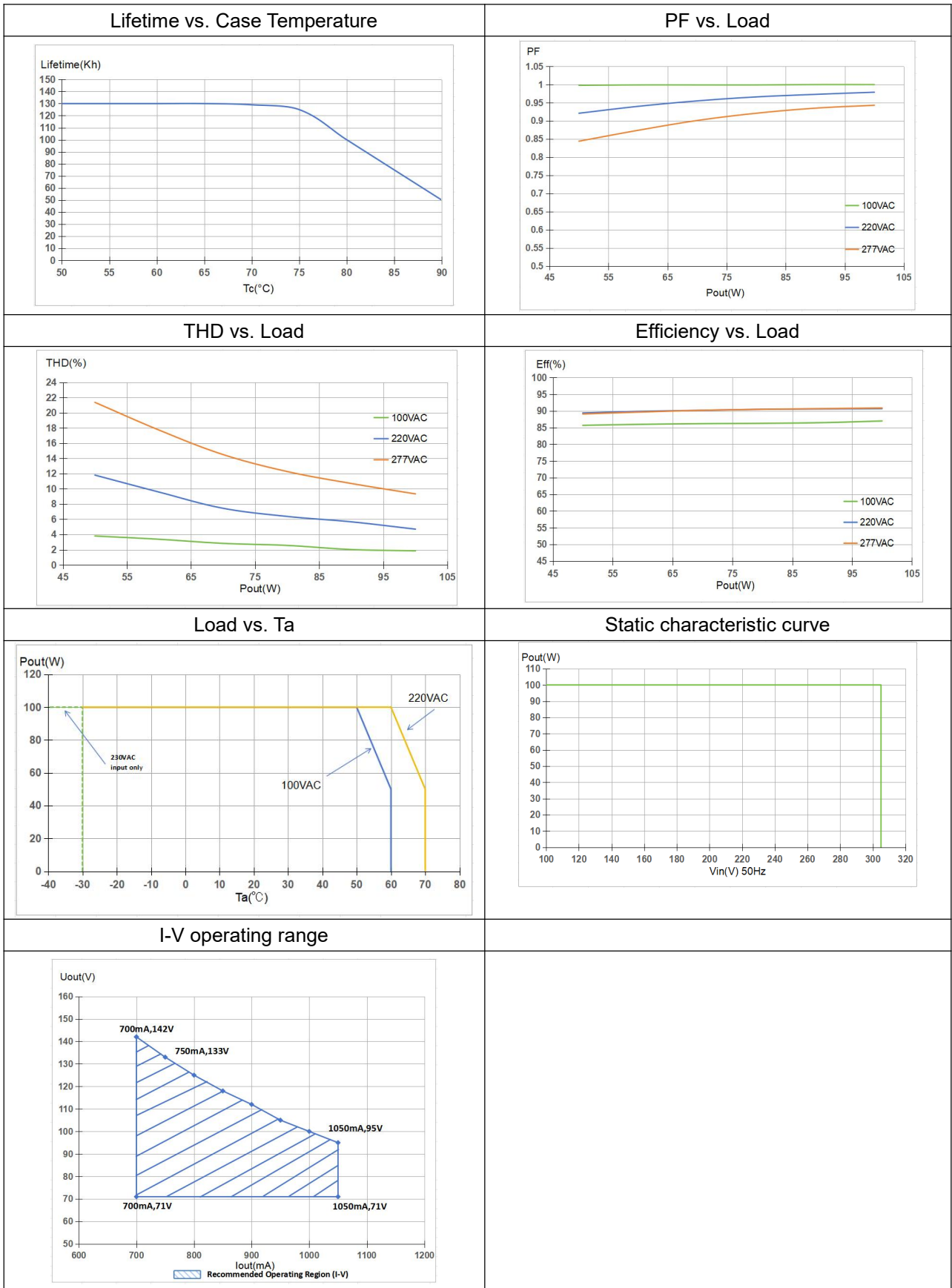

XC100W1750-2780:

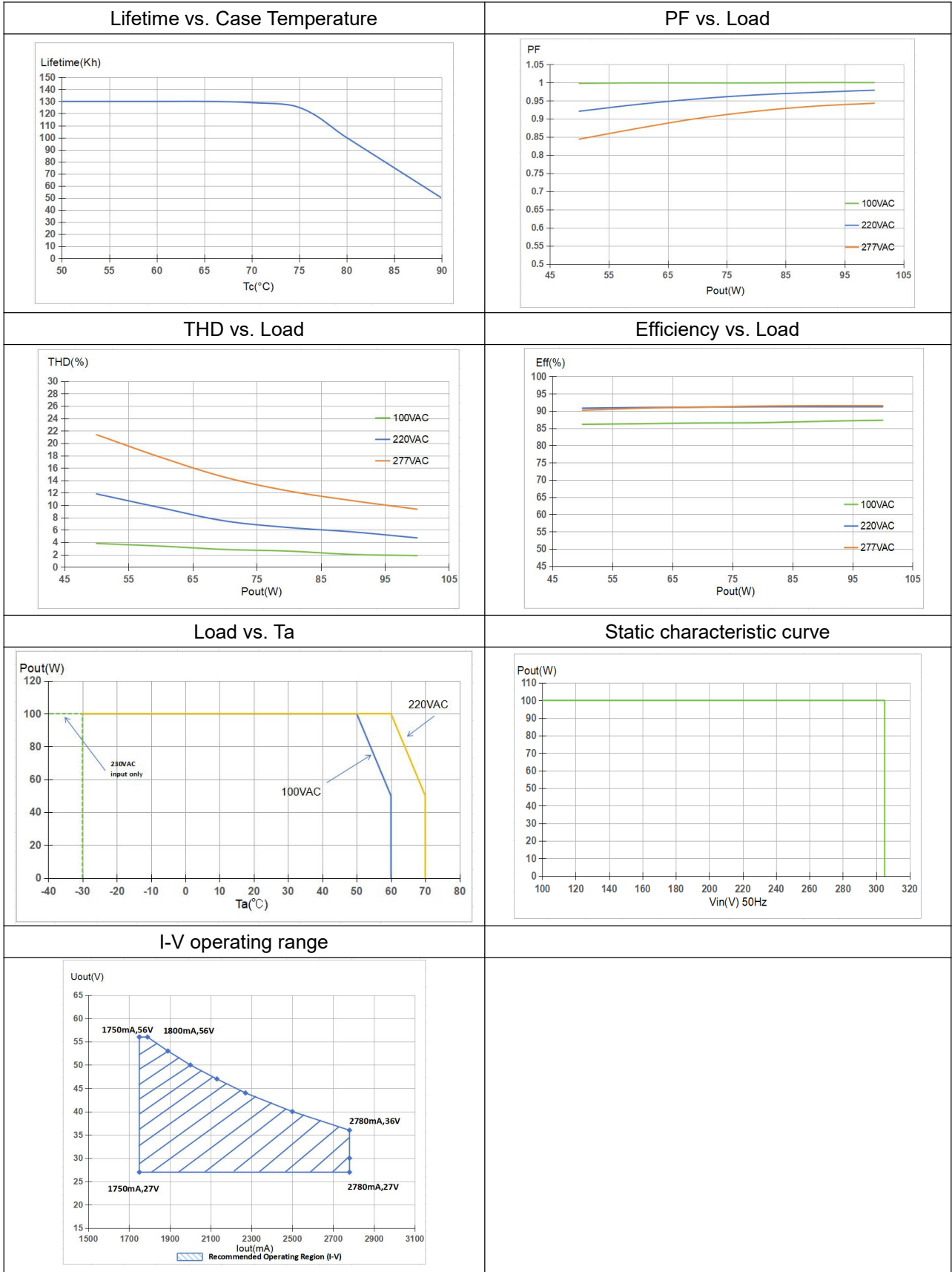

XC150W500-1150:

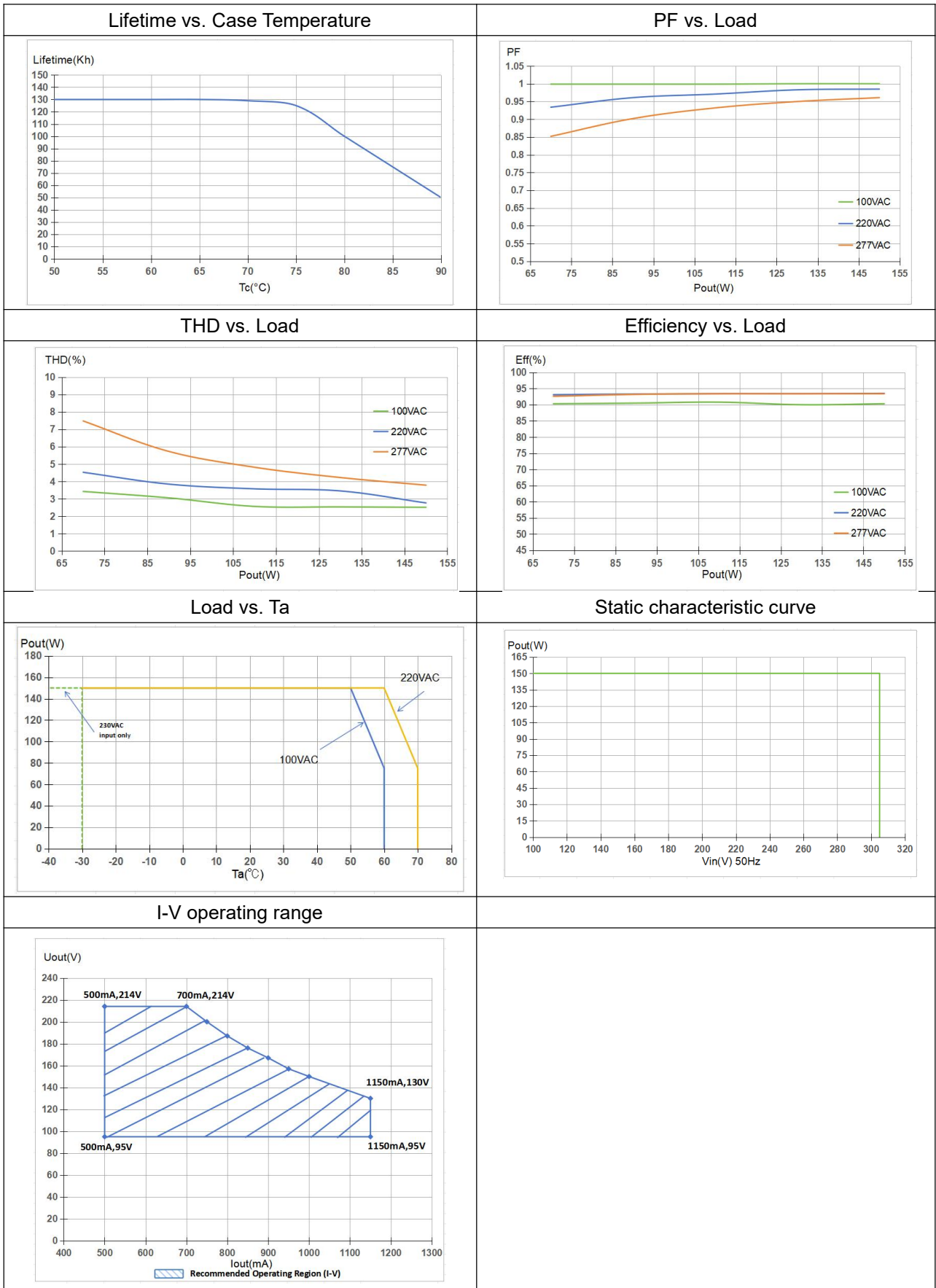

XC150W1800-4200:

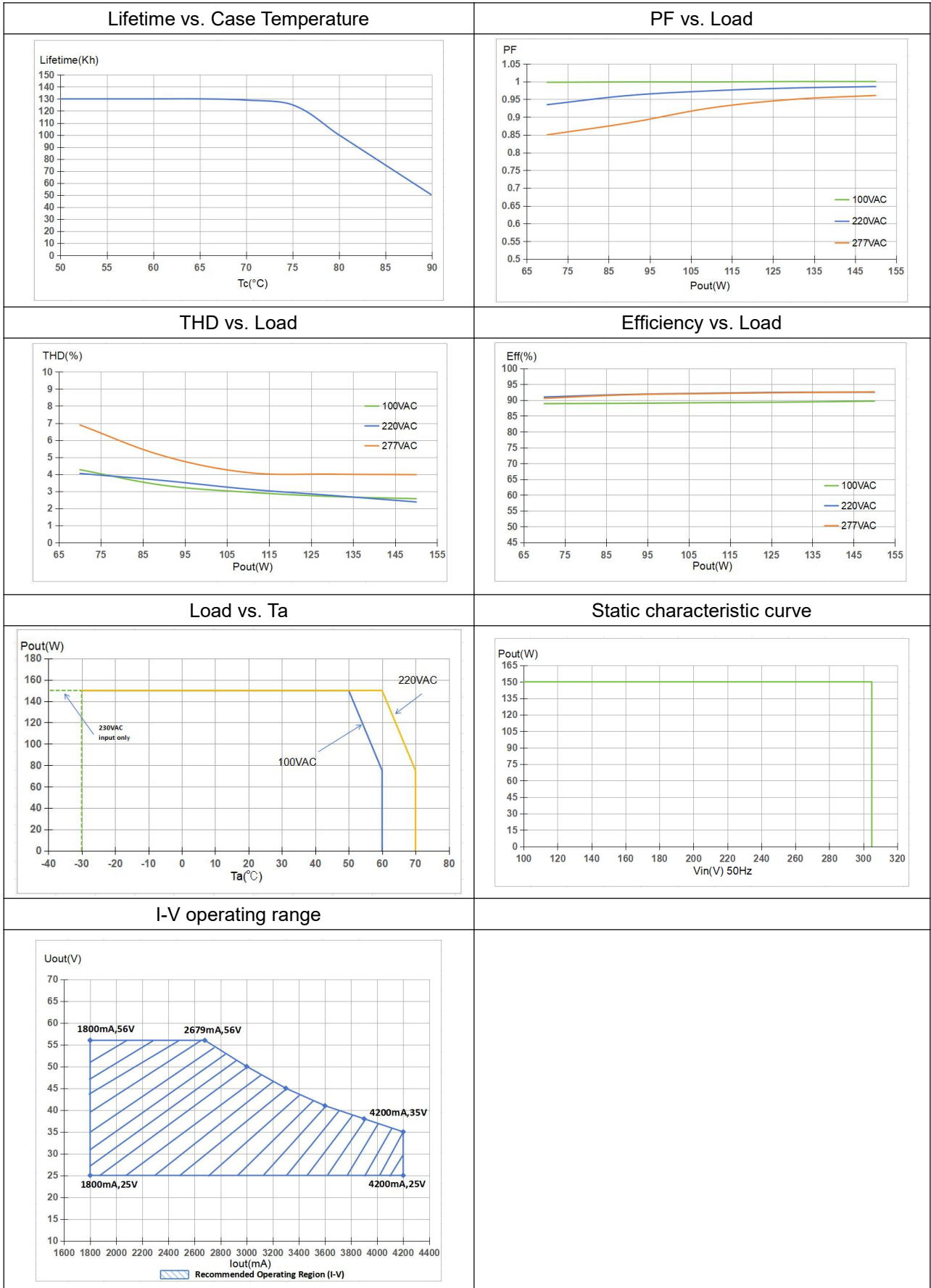

5. Dimension (Unit: mm)

XC50W530-1400 & XC50W1450-2100

XC75W700-1050 & XC75W1300-2100

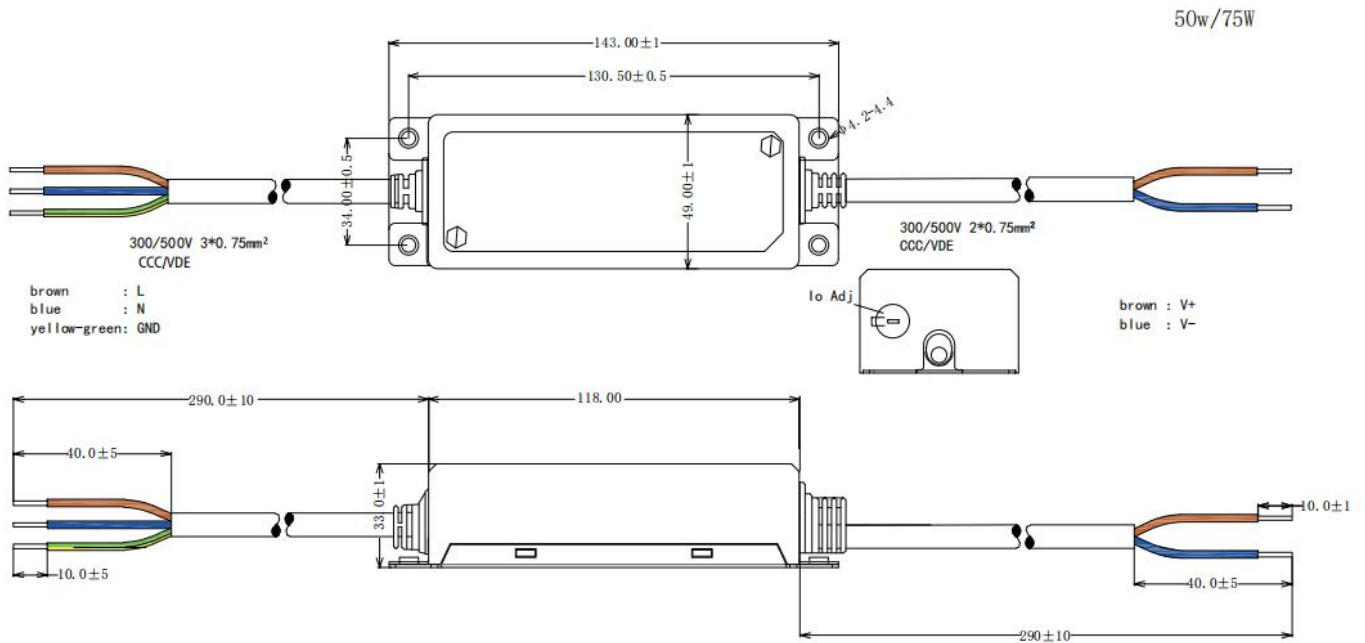

XC100W700-1050 & XC100W1750-2780

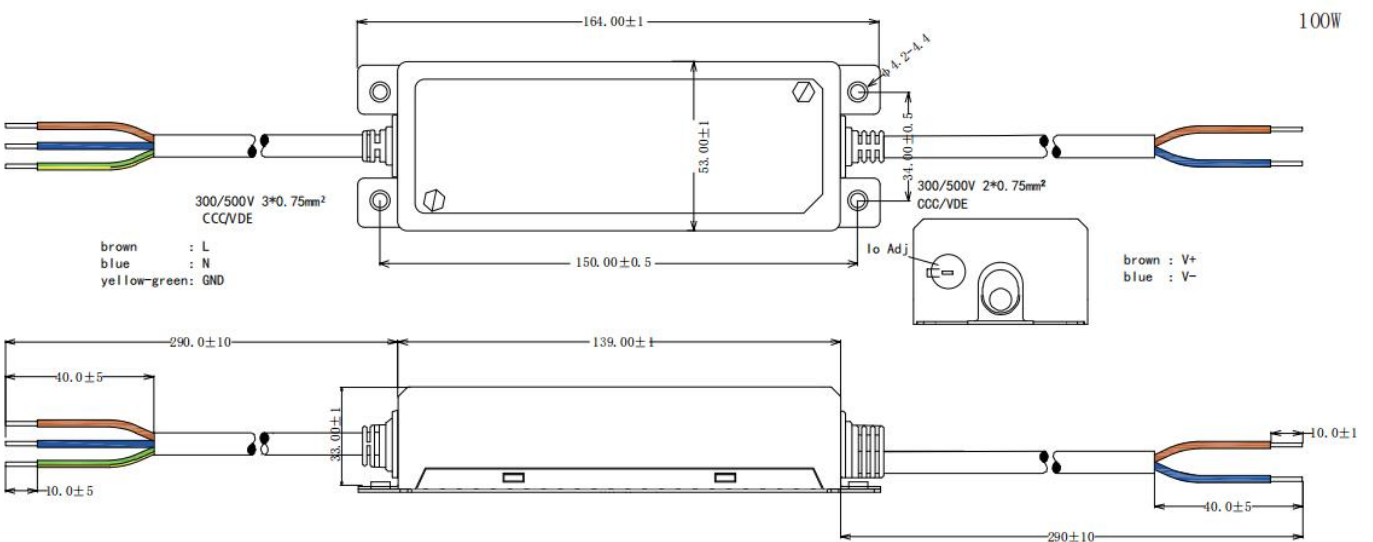

XC150W500-1150 & XC150W1800-4200

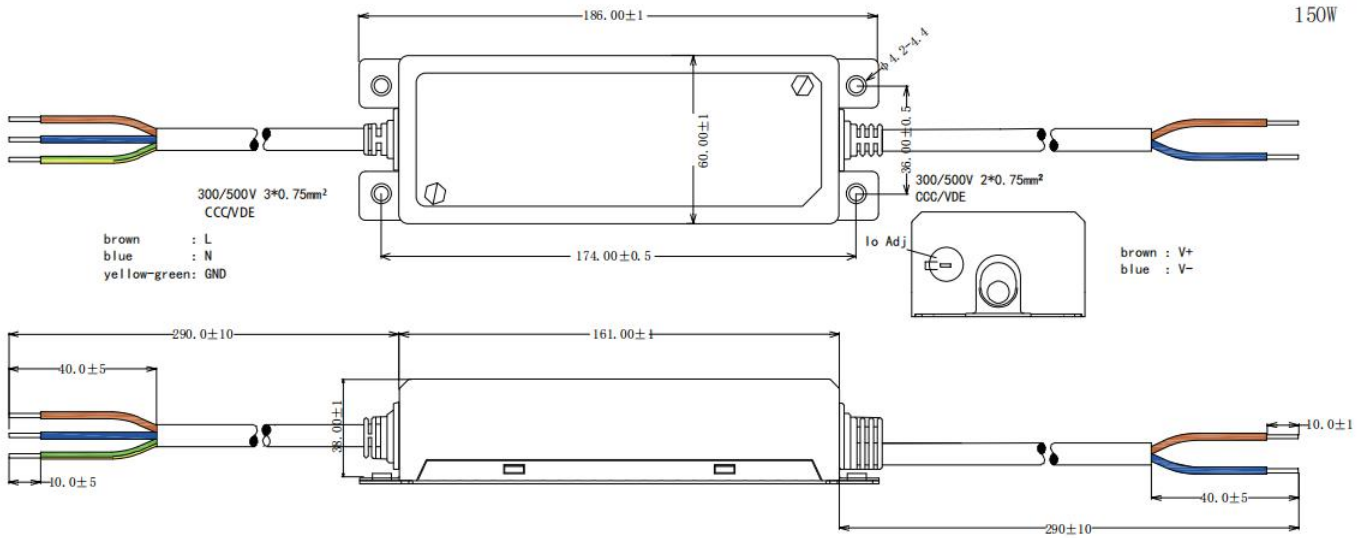

6. Recommended mounting method

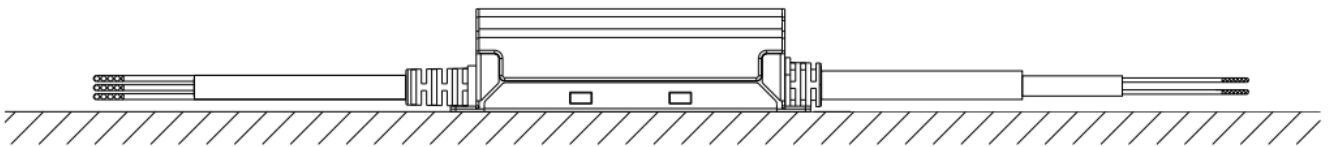

7. Packing information

Packing way	Model	Colour	Carton L*W*H(mm)	Pcs/ Carton (g)	Net weight/ Pcs(kg)	Net weight/ Carton(kg)	Gross weight/ Carton(kg)
Industrial	XC50W530-1400	Silver-white	L345*W310*H158	32	0.36	11.5	12.6
Industrial	XC50W1450-2100	Silver-white	L345*W310*H158	32	0.36	11.5	12.6
Industrial	XC75W700-1050	Silver-white	L375*W245*H220	30	0.43	12.9	14.1
Industrial	XC75W1300-2100	Silver-white	L375*W245*H220	30	0.43	12.9	14.1
Industrial	XC100W700-1050	Silver-white	L420*W280*H210	30	0.58	17.4	18.6
Industrial	XC100W1750-2780	Silver-white	L420*W280*H210	30	0.58	17.4	18.6
Industrial	XC150W500-1150	Silver-white	L457*W250*H220	20	0.71	14.2	15.4
Industrial	XC150W1800-4200	Silver-white	L457*W250*H220	20	0.71	14.2	15.4

8. Wiring instructions

- All connections must be kept as short as possible to ensure good EMI behaviour
- Mains leads should be kept apart from LED Driver and other leads (ideally 5 – 10 cm distance)
- Advice the maximum length of output wires is 0.5 m
- Secondary switching is not permitted (Except for constant voltage)
- Incorrect wiring can damage LED modules.
- The wiring must be protected against short circuits to earth (sharp edged metals parts, metal cable clips, louver, etc.)
- Hot plug-in is not supported due to residual output voltage of > 0 V up to mains voltage. Danger to life.
- When connecting an LED load, restart the device to activate the LED output.

9. Replace LED module

- Mains off
- Remove LED module
- Wait for 30 seconds
- Connect LED module again
- Hot plug-in or secondary switching of LEDs is not permitted and may cause a very high current to the LEDs

10. REVISION HISTORY

DATE	REV	Modification details
2026-6-24	V1.0	Initial release.