



深圳扬兴科技有限公司
YangXing Technology Co.,Ltd.of Shenzhen

产 品 规 格 书

SPECIFICATION

产 品 名 称	石英晶体谐振器 QUARTZ CRYSTAL UNITS
型 号	YST310S
料 号	X321532768KGD2SI
标 称 频 率	32.768KHZ-12.5PF-20PM
页 次	共 6 页

批 准	审 核	拟 制
Kevin	Sandy	Andy

确 认 签 章

APPROVAL SIGNATURE

客 户		
客户物料号		
机种 / 型号		
批 准	审 核	检 验

深圳扬兴科技有限公司

产品规格书/ SPECIFICATION	型号	YST310S
I 晶振电性能 Electrical Characteristics		
1. 标称频率 Nominal Frequency	_____ 32.768 _____	KHZ
2. 振动模式 Mode of vibration	_____ 基 波 _____	
3. 工作温度范围 Operating Temperature Range	— <u> 40 </u> °C ~ + <u> 85 </u> °C	
4. 保存温度范围 Storage Temperature Range	—55°C ~ +125°C	
5. 频率偏差 Adjustment Tolerance	± <u> 20 </u> ppm Max at 25°C	
6. 斜率 Parabolic Coefficient	_____ -0.04 _____	
	PPM/°C ²	
7. 等效电阻 Equivalent Series Resistance	_____ 70 _____	
	K Ω Max. at 25°C	
8. 静电容 Shunt Capacitance	_____ ≤ 1.1 _____	
	pF Max	
9. 绝缘电阻 Insulation resistance	500M Ω Min. /DC100V ± 15V	
10. 老化率 Aging	± 3ppm Max	
11. 标字 Marking : 0XXXX or YXC32GDI	<div style="border: 1px solid black; width: 100px; height: 20px; margin: 0 auto; display: flex; align-items: center; justify-content: center;"> XXXXXX </div>	
12. 动态电容 Shunt Capacitance	_____ 4.1 _____	
	pF	
II-1. 测试条件 Test Condition		
1. 负载电容 Load Capacitance	_____ 12.5 _____	
	pF	
2. 激励功率 Level of Drive	_____ 1 _____	
	μ W	
3. 测试仪表 Equipment	250B Crystal Impedance Meter	
TEL: 0755-28444777 FAX: 0755-28444777-812 WEB: http://www.yxc.hk page 2		

----- (签 字)

样品确认后，请将此页签字回传我公司。

深圳扬兴科技有限公司

产品规格书/ SPECIFICATION	型号	YST310S
<p>III. 包装 PACKING 包装方式应符合运输和装卸要求，特殊包装须经双方认可。 Packing must prevent damage during transportation and handing. Specific method will be settled by mutual agreement.</p> <p>IV.对环境影响 INFLUENCE TO ENVIRONMENT 本产品在生产过程中不使用 ODS I，对臭氧层无破坏。 This product doesn't use the class I ODS at any of production process .</p> <p>V. 生产厂家 MANUFACTURE 公司名称: 深圳扬兴科技有限公司 YangXing Technology Co.,Ltd.of Shenzhen</p> <p>VI.其它 OTHERS</p> <p>1. 如果您对本公司产品规格书有疑问或书中未列出，请与我方联系，协商解决及改进。 If you have some doubt or unknowing about this specification, Please contact us for settlement or development.</p> <p>2.我们按照产品规格书要求保证晶体品质，若客户要求具体数据，我们可提供。 We guarantee that quartz crystal unit satisfies this specification, If you need the data, we will provide it.</p> <p>3.变更与联络 (MODIFY AND CONTACT) 本产品在设计、工艺、材料、生产场所、关键设备、操作人员等影响产品质量的因素有变更时，应事先提供更改后的产品并经过质量认可后，方可大批量供货。 When the quality is changed due to the changes of the design, technology, material, manufacture place, main equipment and workers, we will first supply the modified products and obtain approval from you, then start to supply mass production.</p> <p>4.售后服务 (AFTER SALE SERVICE) 若在生产过程中遇到不良品，本公司负责调换，并及时提交不良品的分析及改进措施报告经认可。 If the defection product was found in the production process, we will exchange and provide the improving measures in time.</p>		
<p>TEL: 0755-28444777 FAX: 0755-28444777-812 WEB: http://www.yxc.hk page 3</p>		

深圳扬兴科技有限公司

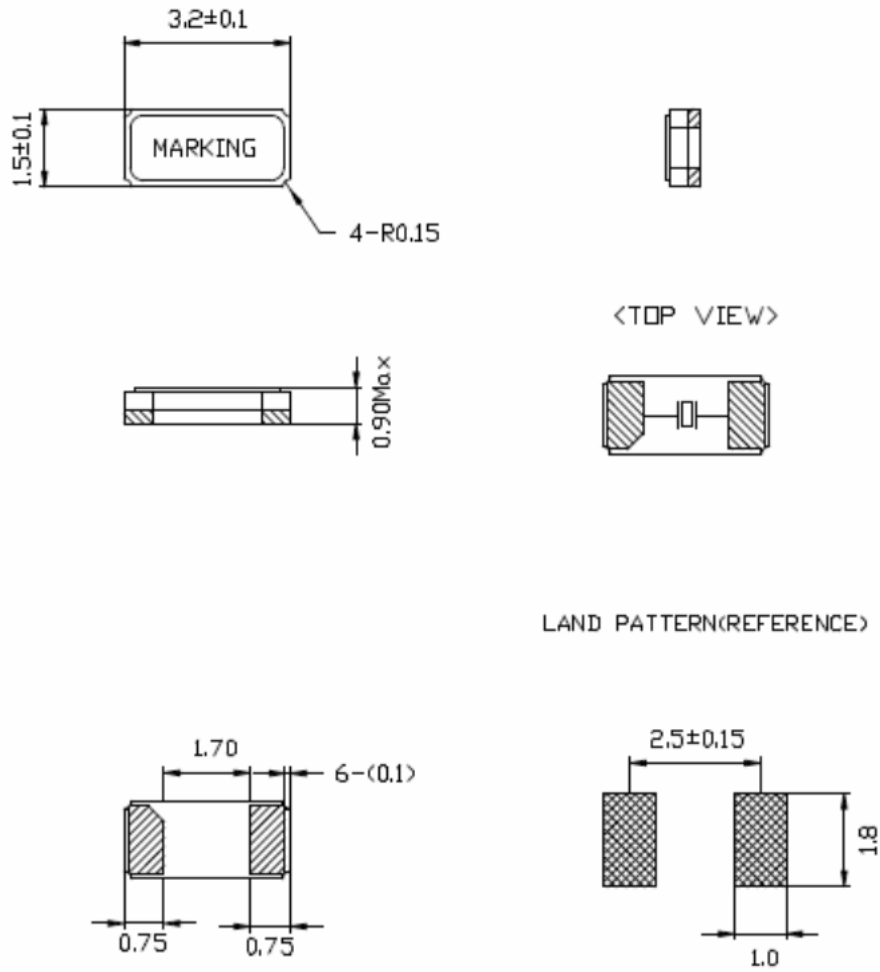
产品规格书/ SPECIFICATION	型号	YST310S
 <p>Technical drawing of the YST310S component. The drawing includes the following views and dimensions:</p> <ul style="list-style-type: none"> Top View: Shows a rectangular component with a width of 3.2 ± 0.1 and a height of 1.5 ± 0.1. The word "MARKING" is located in the center. The corners are chamfered with a radius of $4 \times R0.15$. Side View: Shows the component's profile with a maximum thickness of 0.90 Max. LAND PATTERN (REFERENCE): Shows the reference land pattern for the component. It features two rectangular pads. The distance between the centers of the pads is 2.5 ± 0.15. The width of each pad is 1.0 and the height is 1.8. The distance from the center of each pad to the edge of the component is 1.70. The total width of the component is 6 ± 0.1. 		
<p>TEL: 0755-28444777 FAX: 0755-28444777-812 WEB: http://www.yxc.hk page 4</p>		

深圳扬兴科技有限公司

产品规格书/ SPECIFICATION

型号

YST310S

可靠性试验 RELIABILITY SPECIFICATION

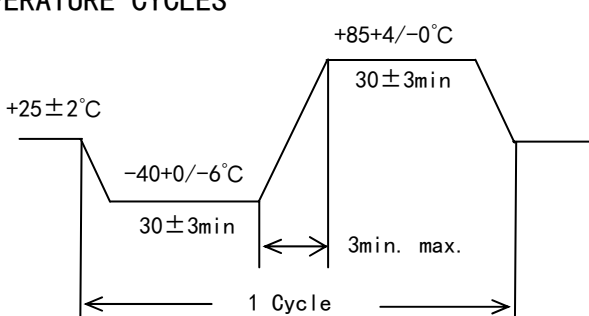
参考标准 REFER		JIS C 6701	
NO.	项目 ITEM	测试条件 CONDITIONS	测试标准 Criteria
1	跌落 FREE FALL	从180cm位置高度跌落在水泥板上,分6个面,每个面跌落3次. Dumy:150g, Height:180cm;Dropped Cycle:3 Cycle DROP IT ONTO A CONCRETE BOARD FOR 6 DIRECTIONS (XX', YY' ZZ') THIS SHOULD BE 1 CYCLE.	B. C
2	振动 VIBRATION	振动频率: 10~55 Hz, 振幅: 1.5mm±15%, 时间: 每个方位三面 (X、Y、Z) 各振动2小时 FREQUENCY: 10~55Hz; AMPLITUDE (TOTAL EXCURSION): 1.5mm±15%; SWEEP TIME: 2-3MIN, 3 DIRECTION (X, Y, Z) EACH FOR 2 Hrs.	A. C
3	冷热冲击 TEMPERATURE CYCLE	晶体放入试验箱中,高、低温循环100次 THE CRYSTAL UNIT SHALL BE SUBJECTED TO 100 SUCCESSIVE CHANGE OF TEMPERATURE CYCLES 	A. C. G
4	气密性 FINE LEAK	氦气压力标准: 5.0~5.5Kg/cm ² , 加压时间: 2小时 HELIUM BOMBING 5.0~5.5 Kg / cm ² , FOR 2 HOURS.	E
5	可焊性 SOLDERABILITY	温度: 260±5°C, 浸锡时间: 2±0.6秒 THE LEAD IS IMMERSED IN A 260±5°C SOLDER BATH WITHIN 2±0.6 SECONDS.	F
6	高温高湿 HIGH TEMP. & HUMIDITY	温度: 60°C ± 2°C, 湿度: 90%~95%, 保持时间: 500个小时 STORED AT 60±2°C AND HUMIDITY 90~95% FOR 500±12 H.	A. C. D. G
7	高温存储 HIGH TEMPERATURE STORAGE	高温温度: 85°C ± 2°C, 时间: 500±12个小时 如果客户的温度要求是高于标准,则必须根据客户的要求测试 STORED AT 85±2°C FOR 500±12H. If Customer's temperature request is higher than the standard, Temperature test must be done for customer requirements	A. C. G
8	低温存储 LOW TEMPERATURE STORAGE	低温温度: -40°C ± 2°C, 时间: 500±12个小时 STORED AT -40±2°C FOR 500±12H. 如果客户的温度要求是低于标准,则必须根据客户的要求测试 If Customer's temperature request is lower than the	A. C. G

深圳扬兴科技有限公司

产品规格书 / SPECIFICATION	型号	YST310S
-----------------------	----	---------

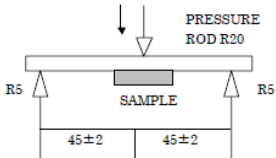
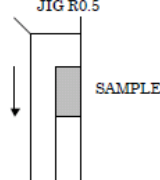
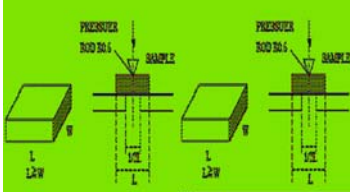
		standard, Temperature test must be done for customer requirements	
9	折板弯曲试验 TERMINAL STRENGTH	<p>弯曲度: 3mm, 保持时间: 5sec, 速度: 0.5mm/sec SHALL BE PRESSURIZED AT A SPEED OF APPROX. 0.5mm/sec IN THE DIRECTION INDICATED BY THE ARROW UNTIL THE BENDING WIDTH REACHES 3mm AND HELD FOR 5 SECONDS.</p> 	B. C
10	折板推力试验 STICKING TENDENCY	<p>荷重: 10N, 保持时间: 10秒, 治具: R0.5(制品侧边位置) A R0.5 JIG SHALL BE USED TO APPLY A 10N DEAD LOAD IN THE DIRECTION INDICATED BY THE ARROW TO THE ELEMENT AND RETAIN IT FOR 10 SECONDS.</p> 	B. C
11	本体荷重试验 ELEMENT ASSEMBLY STRENGTH	<p>荷重: 10N, 保持时间: 10秒, 治具: R0.5(制品中心位置) A R0.5 PRESSURIZED BAR SHALL BE USED TO APPLY A 10N LOAD IN THE CENTER OF ELEMENT AND RETAIN IT FOR 10 SECONDS.</p> 	B. C

SPECIFICATIONS

A	FREQUENCY CHANGE PERMITTED.	$\Delta F \leq 10\text{PPM}$
B	FREQUENCY CHANGE PERMITTED.	$\Delta F \leq 20\text{PPM}$
C	EQUIVALENT SERIES RESISTANCE CHANGE PERMITTED.	$\Delta CI \leq 5\text{K}\Omega$ or 20%
D	INSULATION RESISTANCE	$> 500\text{M}\Omega$
E	LEAK RATE LESS THAN	$< 1 \times 10^{-9} \text{ Pa} \cdot \text{m}^3 / \text{sec}$
F	A NEW UNIFORM COATING OF SOLDER SHALL COVER A MINIMUM 95% OF THE SURFACE	
G	THEN $25 \pm 2^\circ\text{C}$ OVER 2Hr BEFORE TESTING	

Remark:

※ Each test done independently

※ Measurement condition: Electrical characteristics measured by S&A250B or equivalent.