

### Features



- External dimensions: 3.0 x 8.0 mm.
- Frequency range: 32.768KHz.
- Frequency tolerance(standard): ±10ppm.
- Excellent Reliability Performance.
- Applications: clock and Microcomputer.

### Electrical Specifications

Item / Type	YT-38
Nominal Frequency Range	32.768 KHz
Vibration Mode	AT Fundamental
Load Capacitance	12.5pF , or specify
Frequency Tolerance (at 25 °C)	± 10 ppm
Frequency Versus Temperature Characteristics	± 20 ppm
Operating Temperature	- 20 ~ + 70 °C
Storage Temperature	-40~+85 °C , or specify
Shunt Capacitance	1.8pF Max.
Level Of Drive	1 ~ 100 μW ( 1.0 μW Tvp )
Insulation Resistance	More Than 500MΩ at DC 100V
Frequency Aging (at 25 °C)	± 3 ppm / year Max.

### Equivalent Series Resistance(ESR)

Fundamental	
32.768 KHz	40Ω Max.

### Dimensions

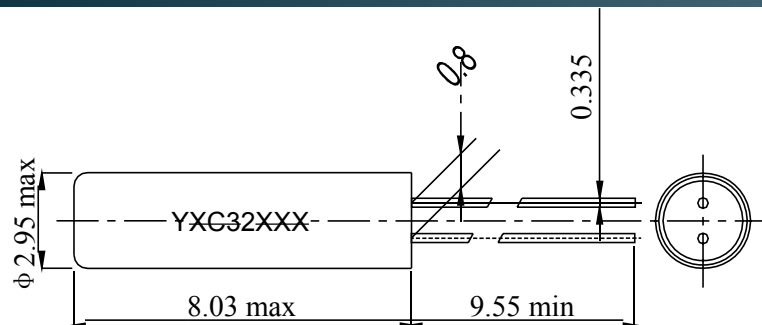

Units: mm( ±0.1mm)

- Mounting of cylinder type products:

Soldering the body of the cylinder type crystal units with PCB must be avoided due to deteriorate the characteristics or damage the products. Rubber adhesive is recommended.

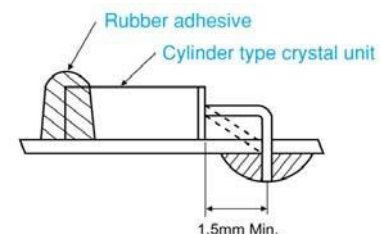

- Soldering

Lead wires should be soldered within 3 seconds with the soldering iron heated to a temperature no higher than 300°C