



RoHS Compliant
Directive 2011/65/EU

REFERENCE SPECIFICATION

Customer: ST MICROELECTRONICS

Item: SAW filter

Type: WFF93A1582UE

Package Type: NS1411UA

Nominal Frequency: 1582.355MHz

Customer's Spec. No.: -----

NDK Spec. No.: WFF93A-03

For your reference we submit this specification.
Please study and keep in your related document file.

Revision Record						
Rev.	Date	Items	Contents	Approved	Checked	Drawn
----	14.Feb.2017	Issue	----	T.Haramatsu	----	H.Fujii
A	20.Feb.2017	Revise	Revise of Att. Spec.	T.Haramatsu	----	H.Fujii
B	10.Mar.2017	Revise	Revise of Att. Spec. due to typing miss. (from 1247 to 1427MHz)	T.Haramatsu	----	H.Fujii
C	30.Oct.2018	Revise	Added NDK Spec. number	T.Haramatsu	----	H.Fujii

1. Scope

This document contains specifications which apply to GPS/GLONASS/BEIDOU SAW filter.
This product is compliant to AEC-Q200.

2. Customer specifications number : -----
3. NDK specification number : WFF93A-03
4. Package Type : NS1411UA
5. Type : WFF93A1582UE

6. Specifications

Parameters		Specifications				Note	
		Min.	Typ.	Max.	Unit		
1	Nominal frequency (Fn)	1582.355				MHz	
2	Max. Insertion loss	1574.42 ~ 1576.42 MHz	-	1.0	1.7	dB	
		1559.05 ~ 1563.15 MHz	-	1.4	2.3	dB	
		1573.37 ~ 1577.47 MHz	-	1.0	2.0	dB	
		1597.78 ~ 1605.66 MHz	-	1.3	2.3	dB	
3	VSWR	1574.42 ~ 1576.42 MHz	-	1.3	2.0	-	
		1559.05 ~ 1563.15 MHz	-	1.5	2.1	-	
		1573.37 ~ 1577.47 MHz	-	1.4	2.0	-	
		1597.78 ~ 1605.66 MHz	-	1.5	2.2	-	
4	Group delay variation	1597.78 ~ 1605.66 MHz	-	4.0	18.0	nsec	
5	Absolute attenuation	50 ~ 824 MHz	40	42	-	dB	
		824 ~ 925 MHz	39	42	-	dB	
		1427 ~ 1453 MHz	40	43	-	dB	
		1710 ~ 1785 MHz	30	38	-	dB	
		1850 ~ 1910 MHz	35	38	-	dB	
		1920 ~ 1980 MHz	35	39	-	dB	
		2400 ~ 2500 MHz	38	43	-	dB	
		2500 ~ 2570 MHz	38	43	-	dB	
2600 ~ 3000 MHz	34	44	-	dB			
6	Operating temperature range	-	-40	-	+105	°C	
7	Storage temperature range	-	-40	-	+105	°C	
8	Moisture Sensitivity Level	-	-	-	-	-	MSL3
9	Max. input power	-	-	-	+15	dBm	CW, 55°C, 50000hours

7. Examination results document

Since a performance is guaranteed, an examination results document does not submit.

8. Usage conditions

Static electricity	Static electricity between signal terminals and grounds may cause degradation or destruction of this component. Please avoid the static electricity when you treat this component.
Pyroelectric noise	Material that is used in the present product (Lithium tantalate), the noise may occur in which the filter output has a pyroelectric effect.
Heat blower	Use of a heat blower is not recommended. When the device temperature is heated to more than 300°C, it may cause a failure. When using a heat blower, note the temperature rise of the device.
Soldering conditions	350 +/- 10°C 5min. However, PCB outer circumference temperature is 360 °C less, the component surface temperature, please set to be 280 °C less.
Storage conditions	When the product of long-term storage, hold our packing state without unpacking, at room temperature 25 ± 10 °C, and stored under the following conditions RH 60% humidity, we recommend the use of within six months. After opening, the room temperature 25 ± 10 °C, and stored at less humidity 60% RH, please use within 7 days.

9. Notice

- 9.1. Order items are manufactured according to specification. As to conditions, which are not indicated in this specification and unpredictable such as applied condition and oscillation margin, please check them beforehand.
- 9.2. Unless we receive request for modification within 3 weeks from the issue date of this NDK specification sheet, we will supply products according to this specification. Also, if you'd like to modify specification of order, which has been placed with delivery request within 3 weeks from the issue data of this specification sheet, we would like to discuss with you separately.
- 9.3. In no event shall the company be liable for any product failure resulting from an inappropriate handling or operation of the product beyond the scope of its guarantee.
- 9.4. Where any change to the process condition is made due to the change(s) in the production line, inform personnel of the specifications.
- 9.5. Should this specification data give rise to any disputes relating to any intellectual property rights or any other rights of a third person, the company shall not indemnify anyone for any damage. Their disclosure must not be construed as the grant of a license to use any of the intellectual property rights owned by the company.
- 9.6. If you intend to use products listed on this specification for applications that may result in loss of life or assets (controls relating to safety, medical equipment, aeronautical equipment, space equipment, etc.), please do not fail to advise us of your intention beforehand.
- 9.7. In the company's production process whatever amount of ozone depleting substances (ODS) as specified in the Montreal protocol is not used.
- 9.8. Information contained in this specification must not be quoted, reproduced or used for other purposes including processing either in part or in full without obtaining prior approval from the company.
- 9.9. Crystal units will be damaged by ultrasonic welding process due to resonance of crystal wafer itself. NDK does not recommend using ultrasonic welding. If Ultra Sonic welding used, NDK strongly recommend verifying crystal unit damage by ultrasonic weld.

10. Application drawing

10.1. Test Circuit	ESD60B-00426
10.2. External dimension	ESD14B-00034
10.3. Taping and reel figure	ESK17B-00024
10.4. Holder marking	ESH11B-00004 Part code : CE
10.5. Reliability assurance Item	ESS30B-00090 AEC-Q200 Compliant
10.6. Recommendation reflow profile	ESS30B-00076
10.7. Recommendation land pattern	ESD15B-00001

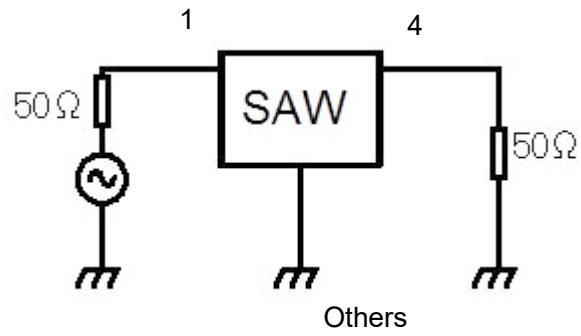

Terminal land connection	
1	INPUT
4	OUTPUT
2,3,5	GND

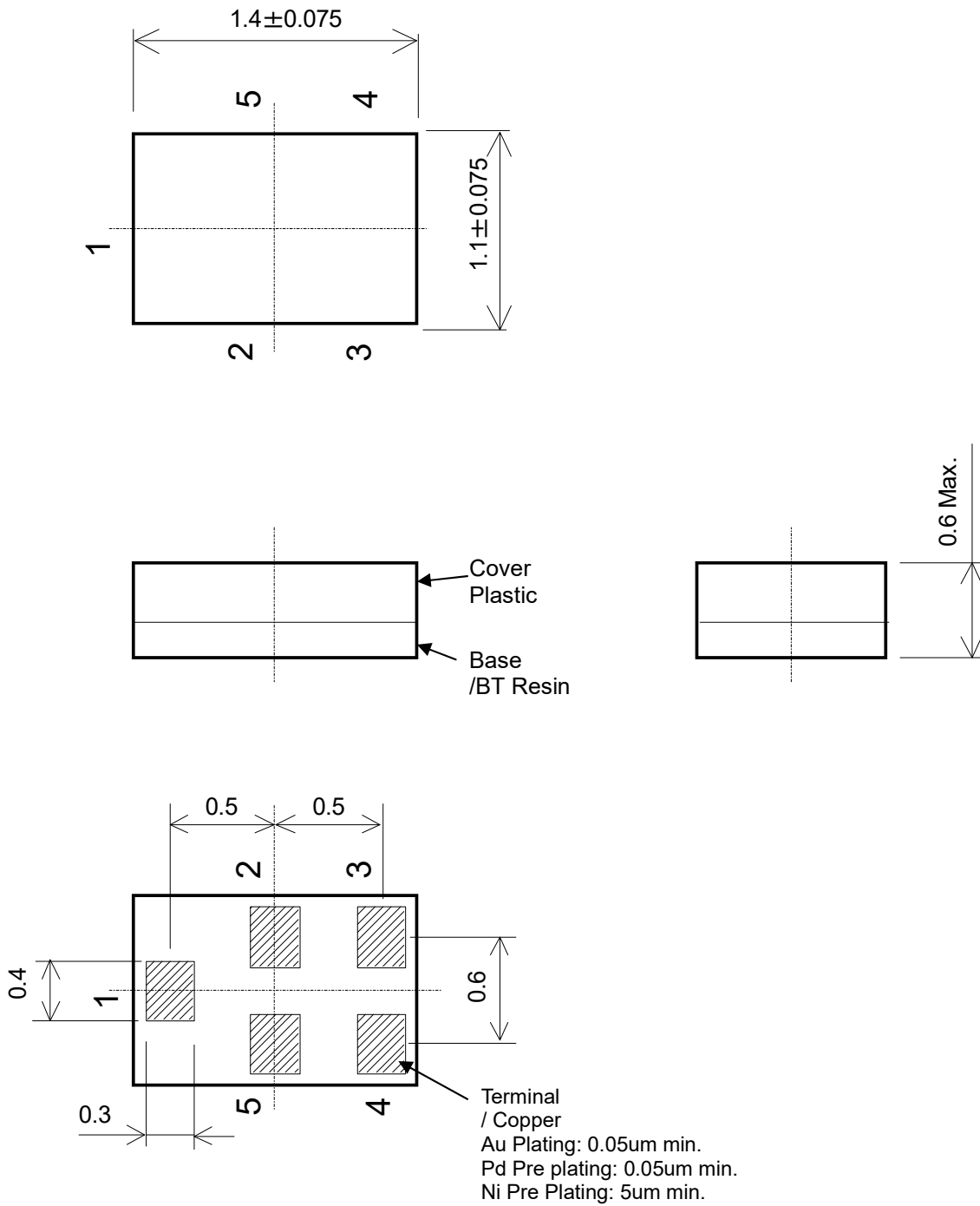

	Date of Revise	Charge	Approved	Reason	
C	28.Sep,2016	H.Fujii	T.Haramatsu	Drawing English version of this document	
	Date	Name	Third Angle Projection	Tolerance	Scale
Drawn	8.Jan.2016	Y. Watanabe	Unit: mm	± 0.1	/
Designed	8.Jan.2016	Y. Watanabe	Title		Drawing No.
Checked	-----	-----	NS1411UA External Dimension		ESD14B-00034
Approved	8.Jan.2016	R. Kajihara			
					C

NIHON DEMPA KOGYO CO., LTD.

Dimension of Tape

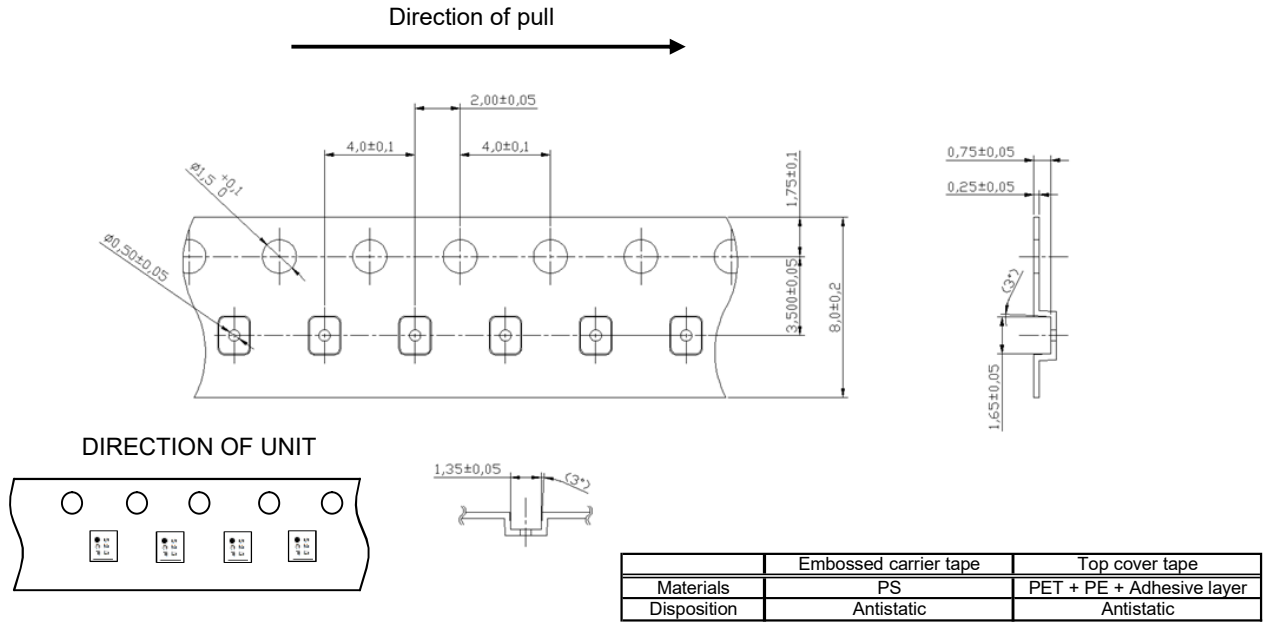

Dimension of Reel

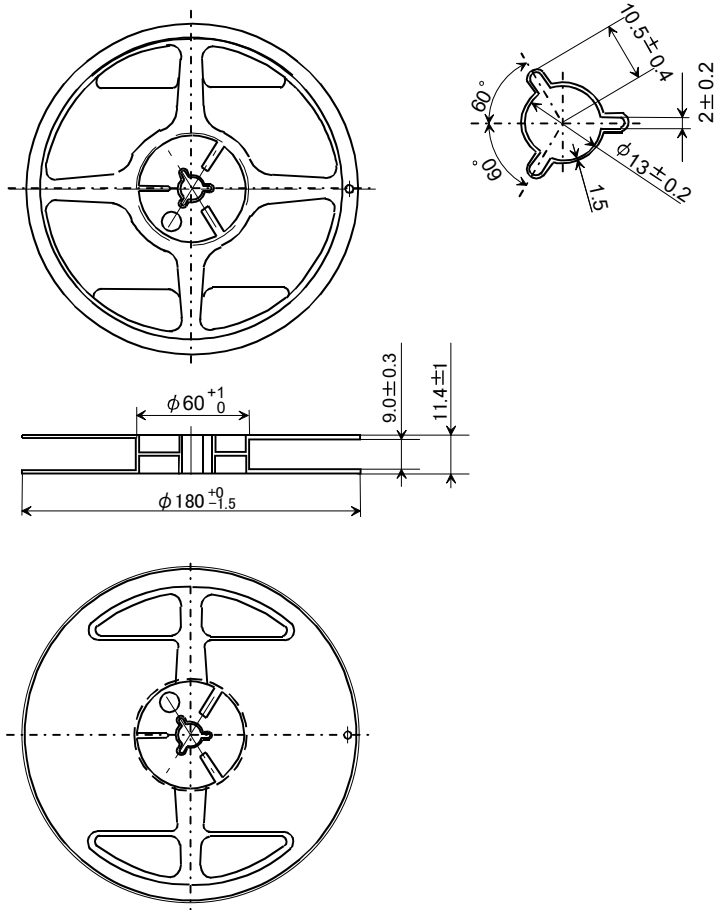

Reel material: Conductive PS

EIAJ standard reel

Date of Revise	Charge	Approved	Reason
5.Jul.2016	Y.Sakuraba	T.Haramatsu	Drawing English version of this document
Date	Name	Third Angle Projection	Tolerance
10.May.2016	H.Fujii	Unit: mm	Scale
Designed	Checked	Approved	Rev.
10.May.2016	R.Kajihara	T.Haramatsu	B
Title		Drawing No.	
NS1411UA Taping and Reel Spec.		ESK17B-00024 1/2	

NIHON DEMPA KOGYO CO., LTD.

Direction of reel

Guiding holes are on the right side of a carrier-tape when a tape is pulled off from upper side of the reel toward this side.

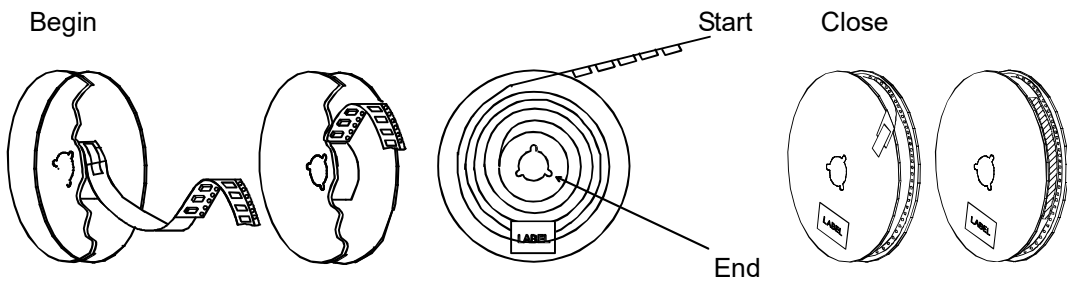
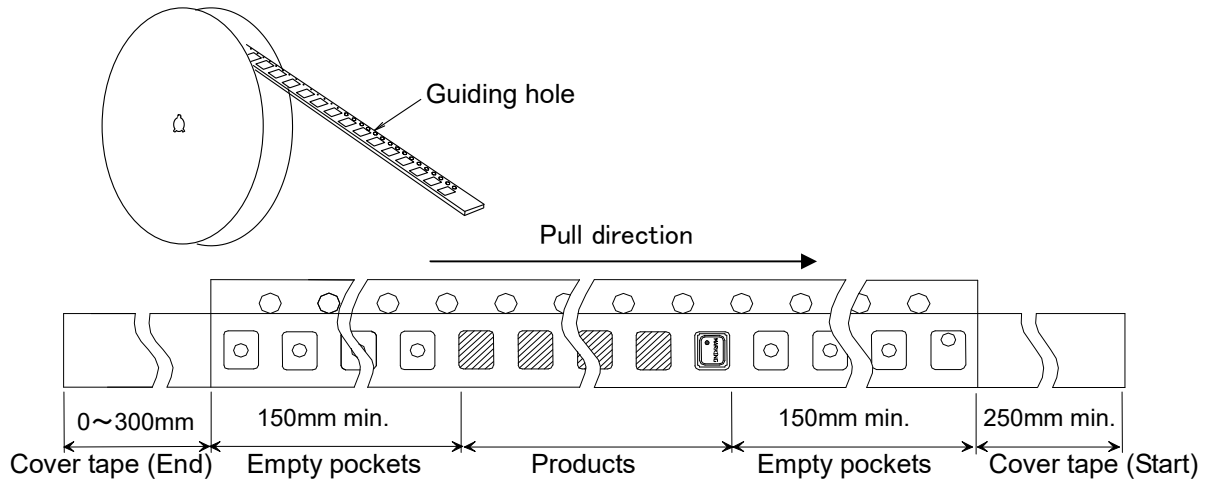

Roll method: 2 kinds of method

Sealing method: 2 kinds of method

2000pcs- Product tape

Pulling Force

Pulling Force: 0.15N to 0.7N, Velocity: 300±10 mm/min

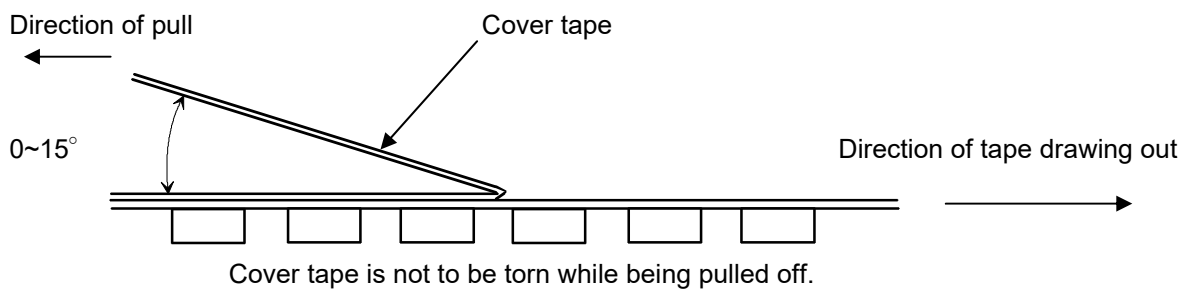

	Date of Revise	Charge	Approved	Reason		
B	5.Jul.2016	Y.Sakuraba	T.Haramatsu	Drawing English version of this document		
	Date	Name	Third Angle Projection	Tolerance	Scale	
Drawn	10.May.2016	H.Fujii	Unit: mm			
Designed	10.May.2016	H.Fujii	Title	Drawing No.	Rev.	
Checked	10.May.2016	R.Kajihara				
Approved	10.May.2016	T.Haramatsu				
			NS1411UA Taping and Reel Spec.		ESK17B-00024 2/2	B

NIHON DEMPA KOGYO CO., LTD.

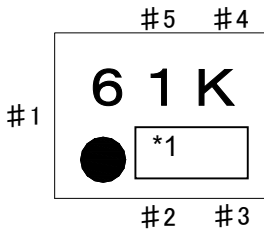

Marking	Description
●	Dot #1 Direction
*1	Part code(Alphabet 2 digits)
6 1 K	Lot number 6 : Year of manufacturing(Lower one column of the year) 1 : Month of manufacturing (See the bellow table) K : /Day of manufacturing (See the bellow table)

*If it is possible to distinguish the marking, this part is acceptable.

Table Month code of manufacturing

Month	1	2	3	4	5	6	7	8	9	10	11	12
Code	1	2	3	4	5	6	7	8	9	O	N	D

Table Day code of manufacturing

Day	1	2	3	4	5	6	7	8	9	10	
Code	1	2	3	4	5	6	7	8	9	A	
Day	11	12	13	14	15	16	17	18	19	20	
Code	B	C	D	E	F	G	H	J	K	L	
Day	21	22	23	24	25	26	27	28	29	30	31
Code	M	N	P	Q	R	S	T	V	W	X	Y

	Date of Revise	Charge	Approved	Reason	
A	28.Sep.2016	H.Fujii	T.Haramatsu	Drawing English version of this document	
	Date	Name	Third Angle Projection	Tolerance	Scale
Drawn	20.Jun. 2016	H.Fujii	Unit: mm		/
Designed	20.Jun. 2016	H.Fujii	Title SAW Marking	Drawing No. ESH11B-00004	Rev. A
Checked	-----	-----			
Approved	20.Jun. 2016	T.Haramatsu			

NIHON DEMPA KOGYO CO., LTD.

Reliability assurance item

(page: 1/1)

	Test item	Test methods	Spec. code
1	High temperature storage	Temperature: +105°C Duration: 1000H	A
2	Low temperature storage	Temperature: -40°C Duration: 1000H	A
3	Temperature humidity	Temperature: +85°C Humidity: 85%RH Duration: 1000H	A
4	Thermal shock	Temperature: -40°C / +105°C Time: each 30 min. (1h/cycle) Test cycles: 1000 cycles	A
5	Vibration	Freq./Amplitude: 10-55Hz, Sweep time: 1 min. Amplitude: ±0.75 mm, Direction: XYZ Duration: 2h in each direction	A
6	Mechanical shock	Half sine shock pulses: 6 msec, Amplitude: 100G 6 each direction, 3 times (Total: 18 times)	A
7	Soldering	Temperature: 350+/-5°C Time: 5 sec.	A
8	ESD	Machine Model : 50 V Human Body Model : 100 V	A

Spec. Code	Spec
A	To satisfy the electrical characteristics

Sn-3.0Ag-0.5Cu Pb free solder reflow condition

IR reflow condition

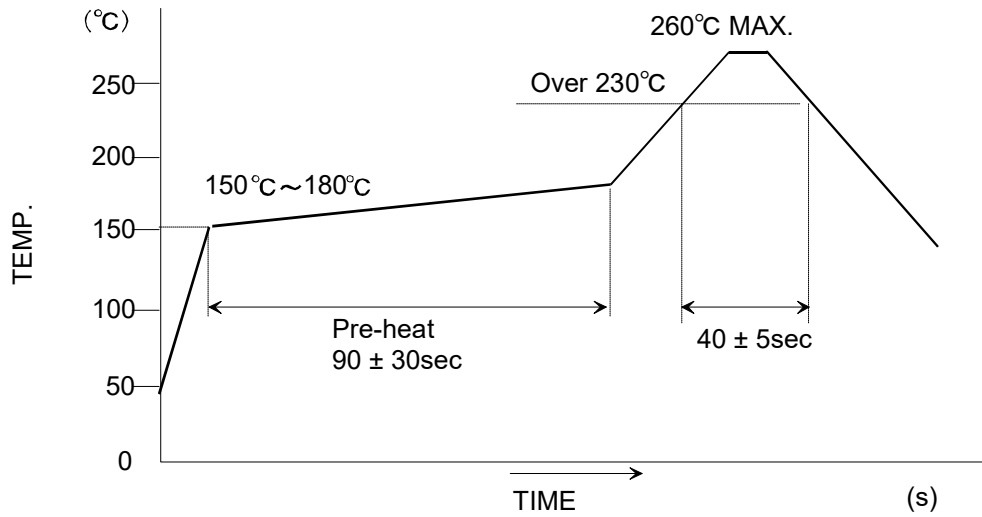

Raising the temp. gradient	Typ.-2.5degC /sec Max. 3.0degC /sec to 150degC
Pre-heating	150~180degC for 60~120sec, Typ90sec
Raising the temp. gradient	Typ-2.5degC /sec Max. 3.0degC /sec to 230degC
Heating	Min. Temp. 230degC for 35~45sec
Max. temperature	Max. Temp. 260degC for 5 ~10sec
Lowering the tem. gradient	Typ-2.5degC /sec to room Temp.
Reflow	3 times

Recommended land pattern

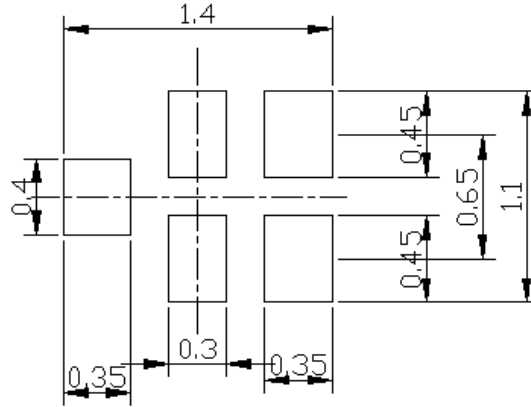

	Date of Revise	Charge	Approved	Reason	
A	28.Sep.2016	H.Fujii	T.Haramatsu	Drawing English version of this document	
	Date	Name	Third Angle Projection	Tolerance	Scale
Drawn	16.May.2016	H.Fujii	Unit: mm	±0.1	/
Designed	16.May.2016	H.Fujii	Title	Drawing No.	Rev.
Checked	16.May.2016	R.Kajihara			
Approved	16.May.2016	T.Haramatsu			
			Recommended land pattern	ESD15B-00001	A

NIHON DEMPA KOGYO CO., LTD.