

Mechanical:

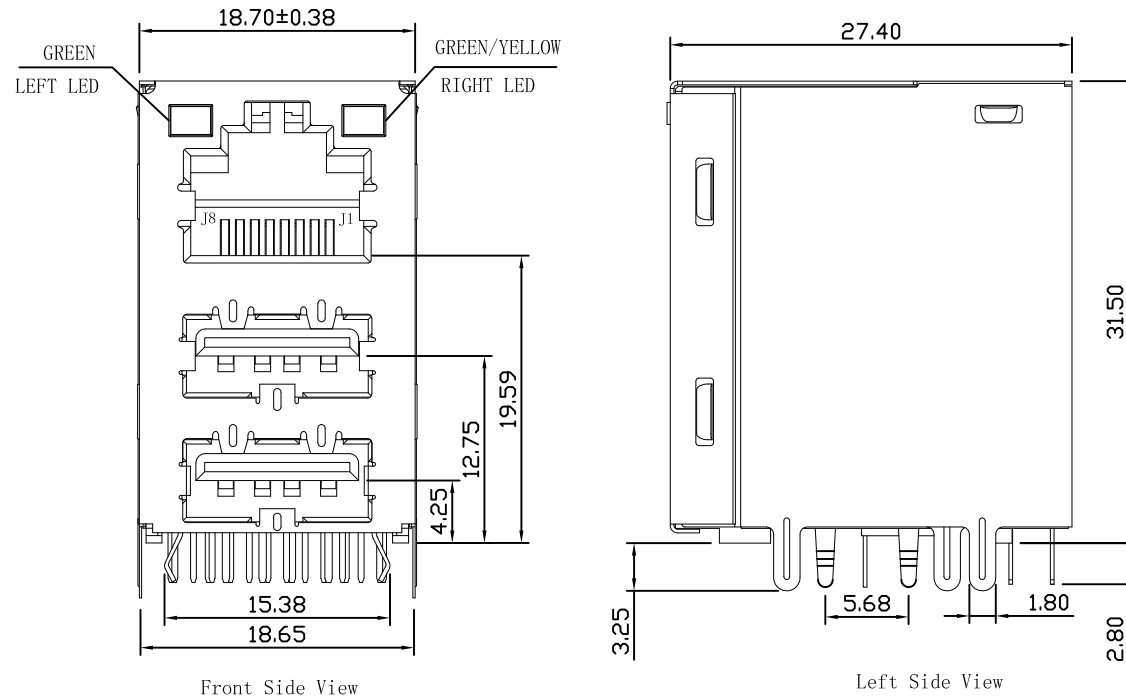

Front Side View

Left Side View

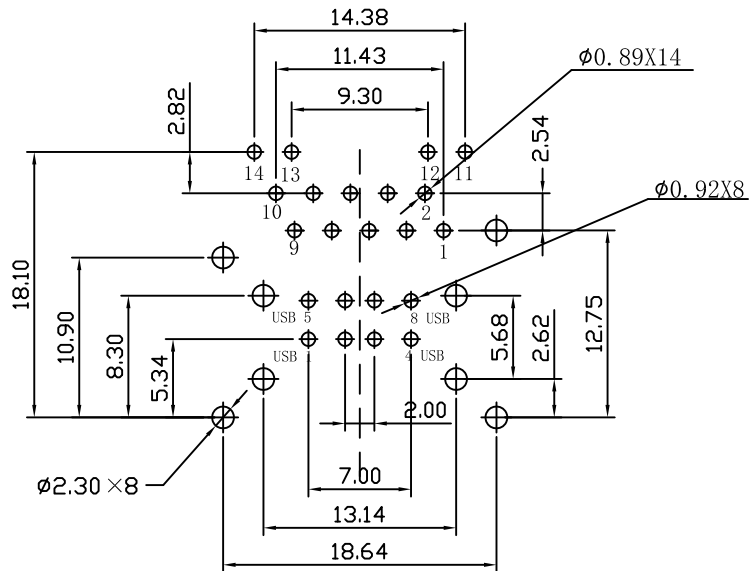

Suggested PCB Layout



REV.	ECN NO.	DESCRIPTION	DATE	APPD
A	REL		2015-05-19	



Top Side View

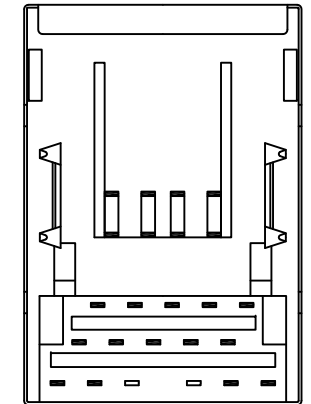

Bottom Side View

NOTES:

- Meets IEEE 802. specification
- Connector Materials:
 Housing Material: Thermoplastic PBT+30%G. F UL94V-0
 Contact Material: Phosphor Bronze C5210R-EH Thickness=0.35mm
 Pins: Brass C2680R-H Thickness=0.35mm
 Shield: SUS 201-1/2H Thickness=0.35mm
 Contact plating: Gold 6 micro-inches min. In contact area.
 USB Contact plating: Gold 6 micro-inches min.
- Wave solder tip temperature: 265°C Max, 5 Sec.
- UL Certification: File Number E321120

X:X ±0.25	APPD:	Trxcom HuiZhou Trxcom Electronics Co., Ltd.
X:XX ±0.20	CHKD:	
X:XXX ±0.05	DR: SEA	TITLE: RJ45 Connector with 1000 Base-TX Jack/Dual USB Combo
ANGLES ±1°	UNIT: mm	PART NO.: TRJU5303B50NL
	SCALE: 2/1	SHEET: 1/4
	REV: A	DWG NO.: TRC15051921

Schematic:

REV.	ECN NO.	DESCRIPTION	DATE	APPD
A	REL		2015-05-19	

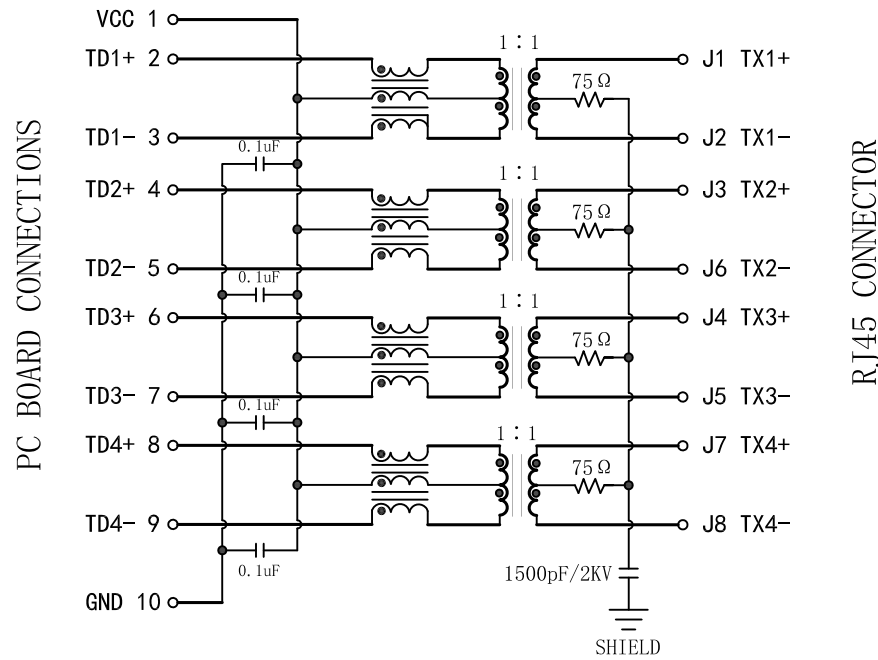

ELECTRICAL SPECIFICATIONS @25°C

- Turn Ratio($\pm 3\%$):
Pri:Sec = 1CT:1CT
- Inductance OCL:
350uH MIN @ 100KHz 0.1V 8mA DC Bias
- DCR: 1.2 Ω MAX
- Insertion Loss:
-1.0dB MAX @ 1-100MHz
- Return Loss:
-18dB MIN @ 1-30MHz
-15dB MIN @ 30-60MHz
-12dB MIN @ 60-100MHz
- Cross talk:
-40dB MIN @ 30MHz
-35dB MIN @ 60MHz
-30dB MIN @ 100MHz
- Common Mode Rejection:
-30dB MIN @ 1-100MHz
- Hipot Test: 1500Vrms
- Operating Temperature Range: 0°C TO 70°C

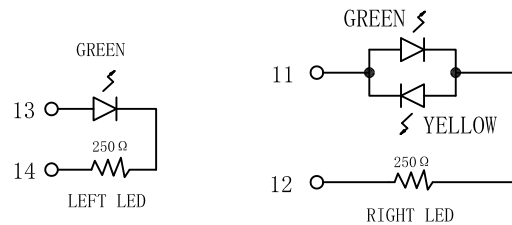

Emitting Color	λ p(nm)	VF@IF=20mA	IR @VR=5V
GREEN	565	1.8~2.4V	10 μ A max
YELLOW	585	1.8~2.4V	10 μ A max



X:X	± 0.25	APPD:	Trxcom HuiZhou Trxcom Electronics Co.,Ltd.	
X:XX	± 0.20	CHKD:		
X:XXX	± 0.05	DR: SEA	TITLE: RJ45 Connector with 1000 Base-TX Jack/Dual USB Combo	
ANGLES	$\pm 1^\circ$	UNIT: mm	PART NO. : TRJU5303B50NL	
	SCALE: 2/1	SHEET: 2/4	REV: A	DWG NO. : TRC15051921

Profile of wave solder:

REV.	ECN NO.	DESCRIPTION	DATE	APPD
A	REL		2015-05-19	

SUGGESTED PROFILE OF WAVE SOLDER FOR ROHS PRODUCT

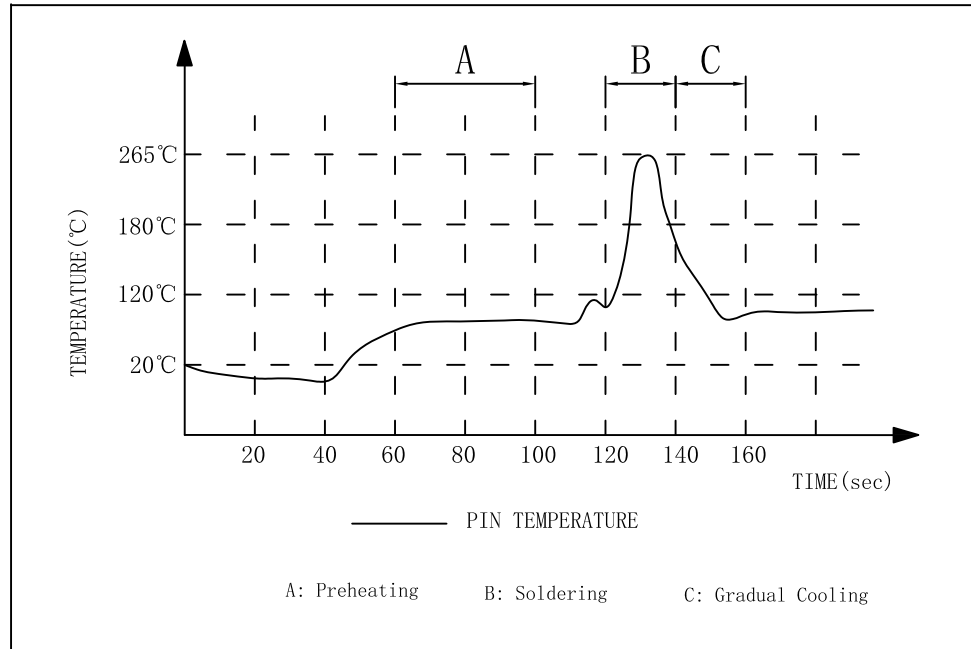

- (1) Tip Temperature: 265°C max
 - (2) Tip Temperature time: 5sec max
- Note: The melting point of Tin: 219°C

X:X	±0.25	APPD:	Trxcom HuiZhou Trxcom Electronics Co.,Ltd.
X:XX	±0.20	CHKD:	
X:XXX	±0.05	DR: SEA	
ANGLES ±1°		UNIT: mm	TITLE: RJ45 Connector with 1000 Base-TX Jack/Dual USB Combo
		PART NO. :	TRJU5303B50NL
	SCALE: 2/1	SHEET: 2/4	REV: A DWG NO. : TRC15051921

Packaging:

REV.	ECN NO.	DESCRIPTION	DATE	APPD
A	REL		2015-05-19	

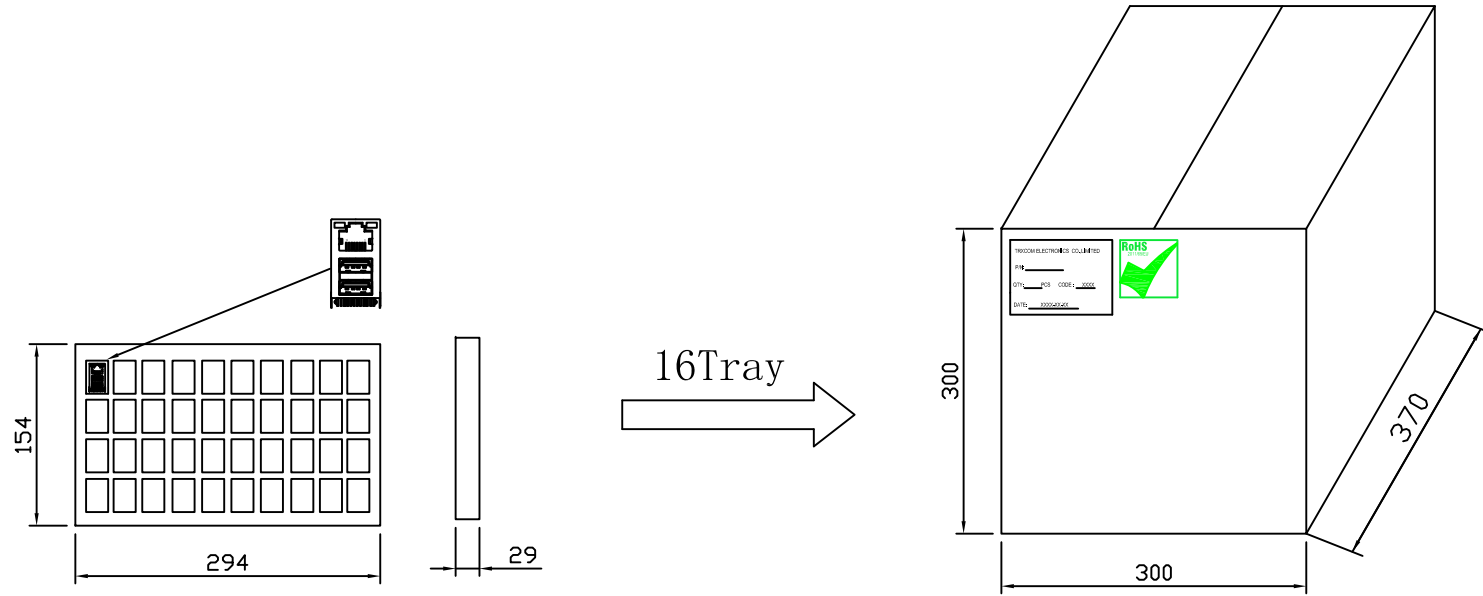

- ◆ Packaging unit :40pcs/tray
- ◆ Packaging material:PVC
- ◆ Outer carton unit:640pcs/16tray/box
- ◆ Net Weight:9kg
- ◆ Gross Weight:10kg

X:X	±0.25	APPD:	Trxcom Huizhou Trxcom Electronics Co.,Ltd.	
X:XX	±0.20	CHKD:		
X:XXX	±0.05	DR: SEA	TITLE: 1*1 RJ45 PACKING	
ANGLES	±1°	UNIT: mm	PART NO. : TRJU5303B50NL	
	SCALE: 2/1	SHEET: 4/4	REV: A	DWG NO. : TRC15051921