

Mechanical :

REV.	ECN NO.	DESCRIPTION	DATE	APPD
A	REL		2015-04-22	

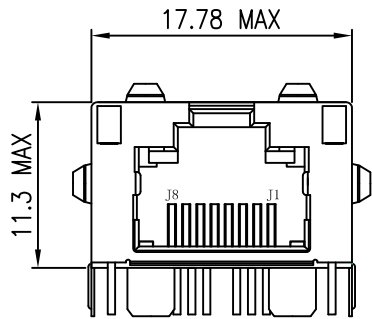

Front Side View

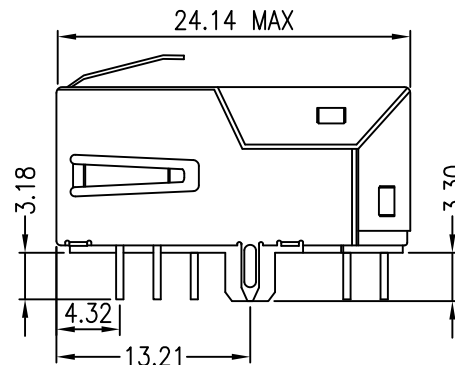

Left Side View

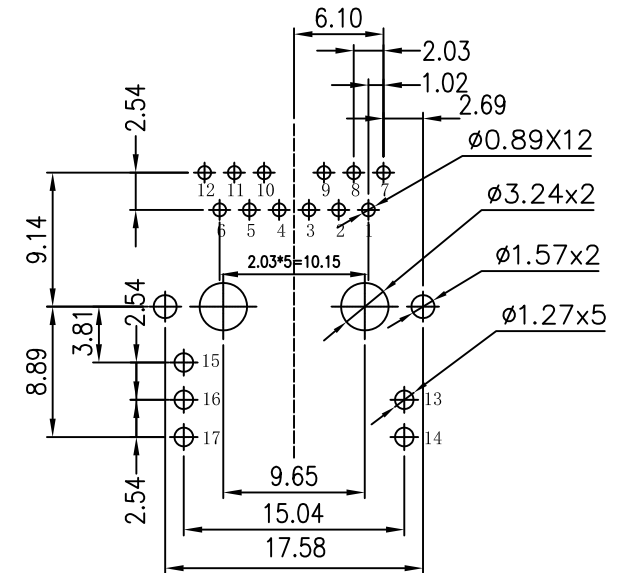

Suggested PCB Layout (Top View)

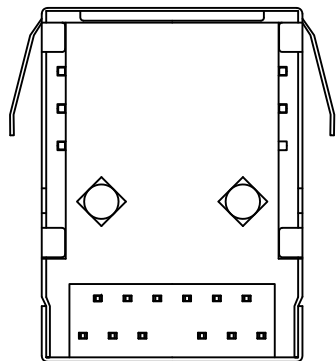

Bottom Side View

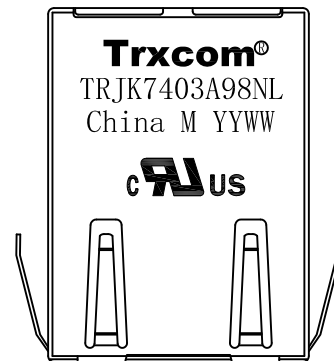

Top Side View

NOTES:

1. Meets IEEE 802.3 specification
2. Connector Materials:
Housing: Thermoplastic UL94V-0
Contact/Shield: Copper alloy
Shield plating: Nickel
Contact plating: Gold 6 micro-inches min. In contact area.
3. Wave solder tip temperature: 265°C Max, 5 Sec Max
4. UL Certification: File Number E321120



X:X	±0.25	APPD:	Trxcom Huizhou Trxcom Electronics Co., Ltd	
X:XX	±0.20	CHKD:		
X:XXX	±0.05	DR: SEA	TITLE: RJ45 Connector with 1000 Base-T Integrated Magnetics	
ANGLES	±1°	UNIT: mm	PART NO.: TRJK7403A98NL	
	SCALE: 2/1	SHEET: 1/4	REV: A	DWG NO.: TRC14011026

Schematic:

REV.	ECN NO.	DESCRIPTION	DATE	APPD
A	REL		2015-04-22	

PCB SIDE TO PHY

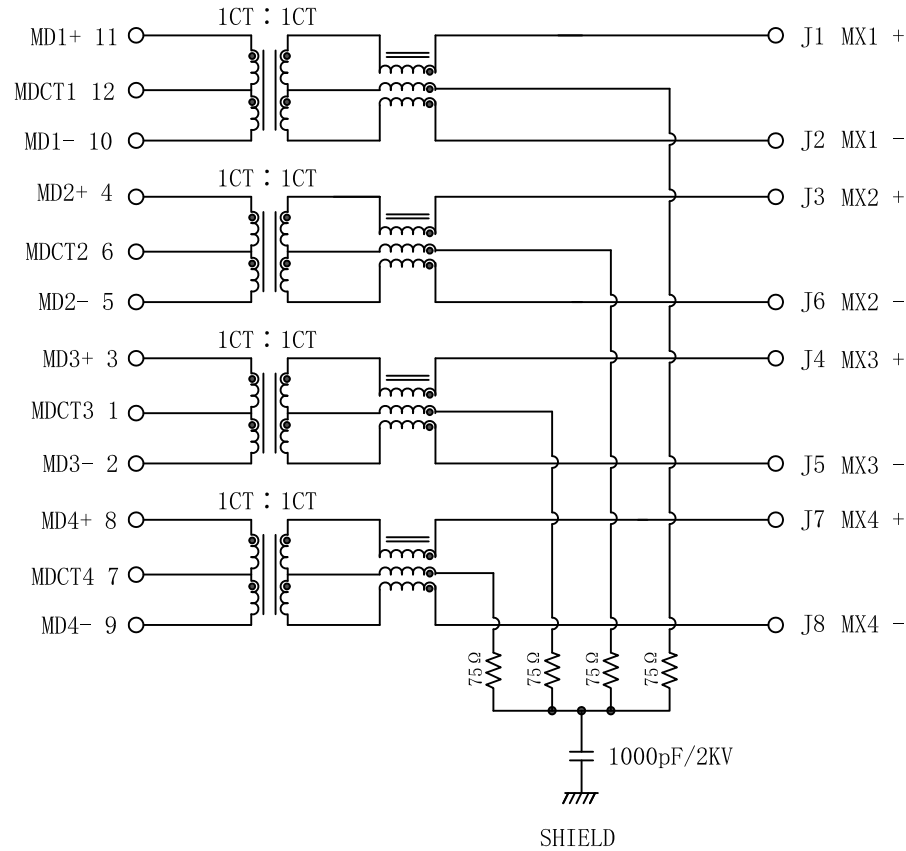

CABLE SIDE

ELECTRICAL SPECIFICATIONS @25°C

- Turn Ratio ($\pm 3\%$):
Pri:Sec = 1CT:1CT
- Inductance OCL:
350uH MIN @100KHz 0.1V 8mA DC Bias
- DCR: 1.2Ω MAX
- Insertion Loss:
-1.0dB MAX @1-100MHz
- Return Loss:
-18dB MIN @1-30MHz
-15dB MIN @30-60MHz
-12dB MIN @60-100MHz
- Cross talk:
-40dB MIN @1-30MHz
-35dB MIN @30-60MHz
-30dB MIN @60-100MHz
- Common Mode Rejection:
-30dB MIN @1-50MHz
-20dB MIN @50-150MHz
- Hipot Test: 1500Vrms
- Operating Temperature Range: -40°C TO +85°C

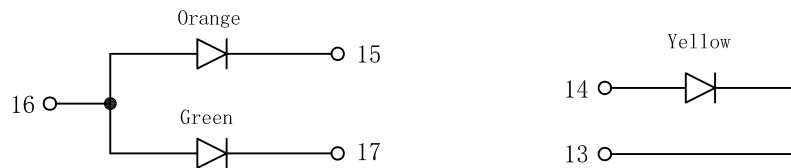

Left LED

Right LED

Emitting Color	λ p(nm)	V _F @I _F =20mA	I _R @V _R =5V
Green	565	1.8~2.4V	10 μA max
Yellow	585	1.8~2.4V	10 μA max
Orange	610	1.8~2.4V	10 μA max

X:X	± 0.25	APPD:	Trxcom	
X:XX	± 0.20	CHKD:	Huizhou Trxcom Electronics Co.,Ltd	
X:XXX	± 0.05	DR: SEA	TITLE: RJ45 Connector with 1000 Base-T Integrated Magnetics	
ANGLES	$\pm 1^\circ$	UNIT: mm	PART NO.: TRJK7403A98NL	
	SCALE: 2/1	SHEET: 2/4	REV: A	DWG NO.: TRC14011026

Profile of wave solder:

REV.	ECN NO.	DESCRIPTION	DATE	APPD
A	REL		2015-04-22	

SUGGESTED PROFILE OF WAVE SOLDER FOR ROHS PRODUCT

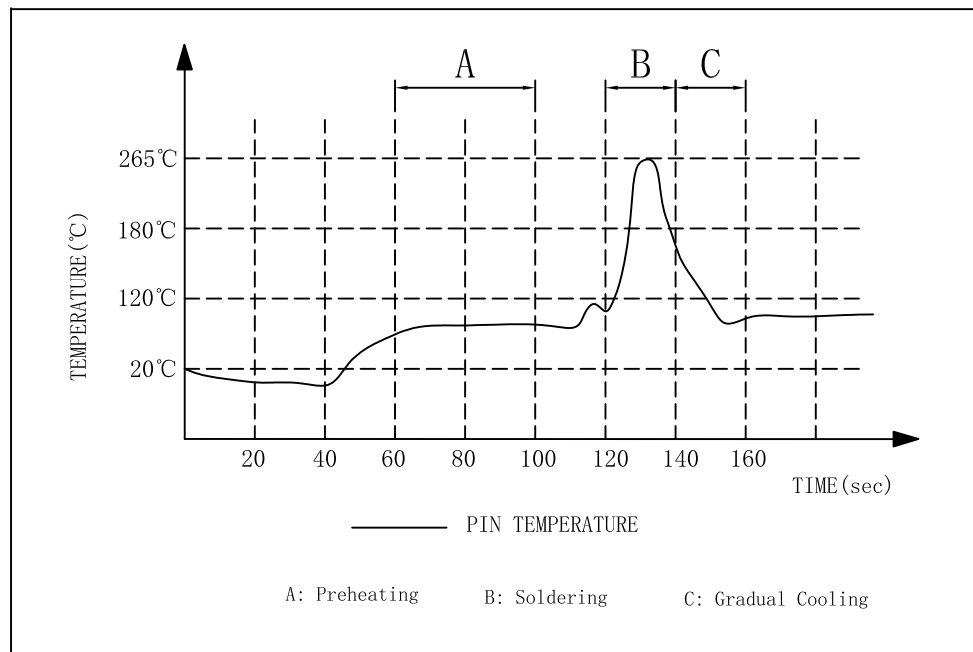

- (1) Tip Temperature: 265°C max
 - (2) Tip Temperature time: 5sec max
- Note: The melting point of Tin: 219°C

X:X	±0.25	APPD:	Trxcom
X:XX	±0.20	CHKD:	
X:XXX	±0.05	DR: SEA	TITLE: RJ45 Connector with 1000 Base-T Integrated Magnetics
ANGLES	±1°	UNIT: mm	PART NO.: TRJK7403A98NL
	SCALE: 2/1	SHEET: 3/4	REV: A DWG NO.: TRC14011026

Packaging:

REV.	ECN NO.	DESCRIPTION	DATE	APPD
A	REL		2015-04-22	

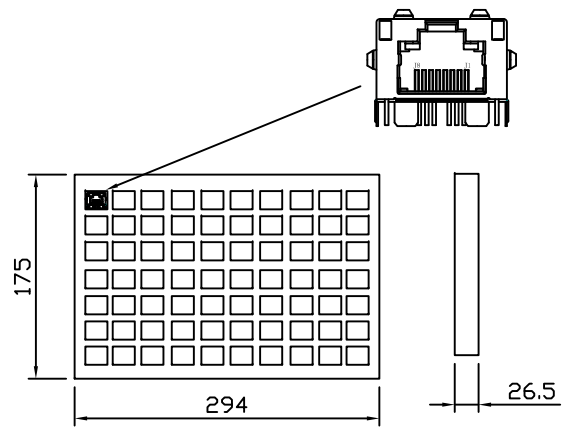

12Tray →

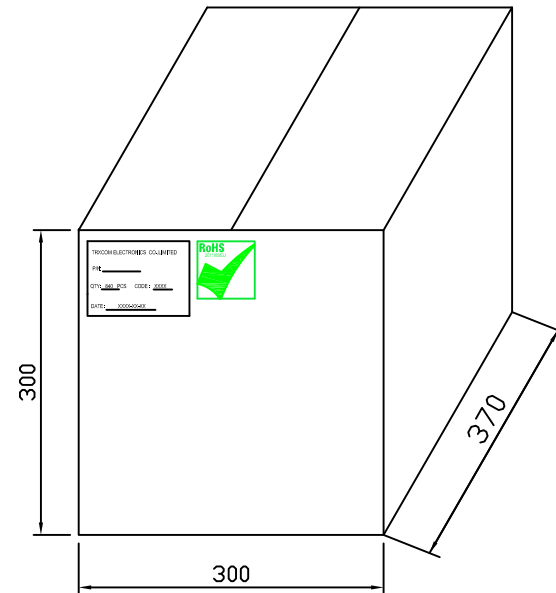

- ◆ Packaging unit :70pcs/tray
- ◆ Packaging material:PVC
- ◆ Outer carton unit:840pcs/12tray/box
- ◆ Net Weight:8kg
- ◆ Gross Weight:10kg

X:X	±0.25	APPD:	Trxcom
X:XX	±0.20	CHKD:	
X:XXX	±0.05	DR: SEA	TITLE: 1*1 24.14 RJ45 PACKING
ANGLES	±1°	UNIT: mm	PART NO.: TRJK7403A98NL
		SCALE: 2/1	SHEET: 4/4
		REV: A	DWG NO.: TRC14011026