

# Mechanical:

REV.	ECN NO.	DESCRIPTION	DATE	APPD
A	REL		2013/06/03	

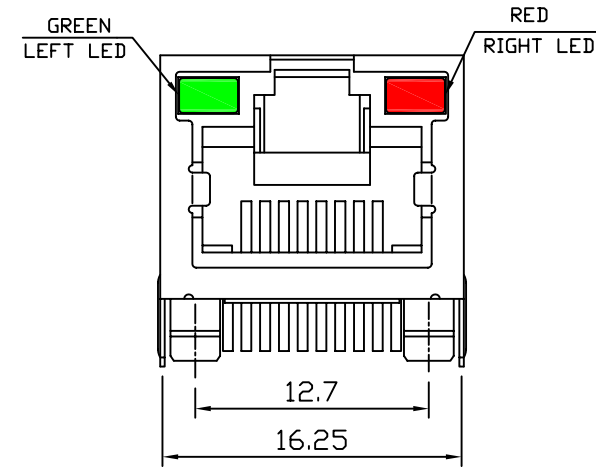
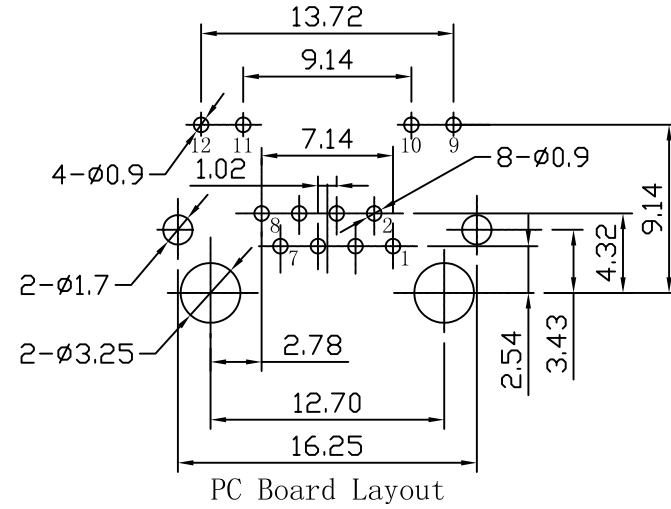
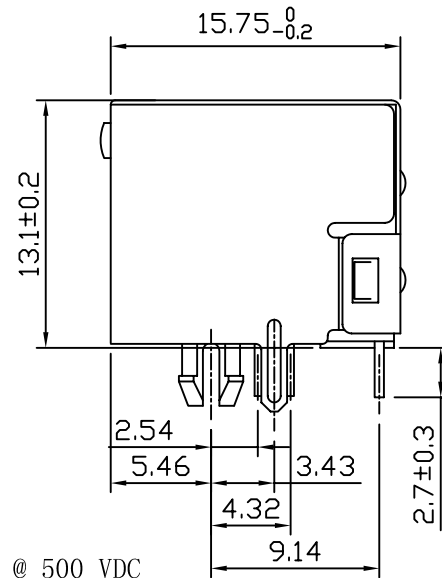
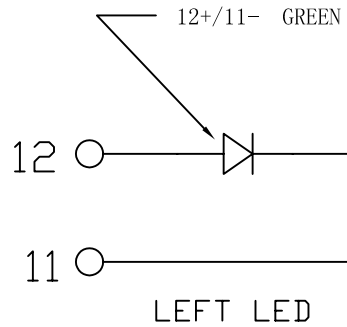
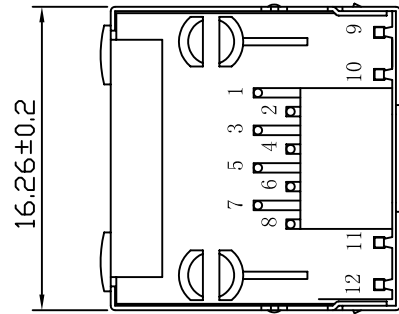
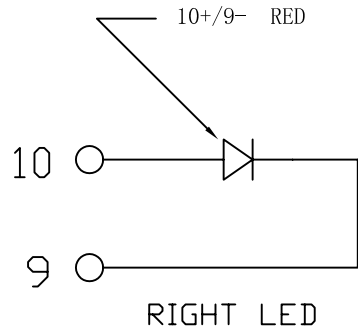

**7. Voltage rating: 125V (AC)**  
**8. Current rating: 1.5A**

### PCB JACK Specification

1. Insulation Resistance: 500M Ω MIN @ 500 VDC
2. Withstanding Voltage: AC1000V 50Hz or 60Hz 1min.
3. Durability: 600 Mating Cycles MIN.
4. Gold Plating: (Gold Flash; 1.5; 3; 6; 15; 30; 50) μ inch
5. (1) Storage: -40°C to +85°C  
(2) Operation: -40°C to +85°C  
(3) Wave solder temperature: 230°C to 250°C, 5~10 Sec.
6. UL certification: file number E321120

X:X ±0.25	APPD:	Trxcom ShenZhen Trxcom Electronics Co., Ltd
X:XX ±0.20	CHKD:	
X:XXX ±0.05	DR: C. H. Y	TITLE: RJ45 1×1 CONNECTOR
ANGLES ±1°	UNIT: mm	PART NO.: TRJE101B33NL
	SCALE: 2/1	SHEET: 1/1
	REV: A	DWG NO.: TRC13060305