

# Mechanical :

REV.	ECN NO.	DESCRIPTION	DATE	APPD
A	REL		2009-05-30	

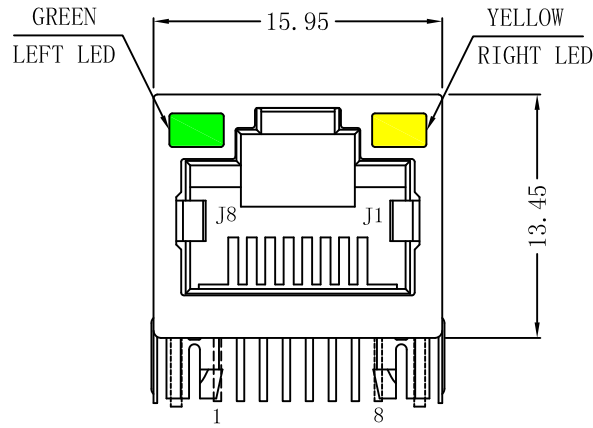

Front Side View

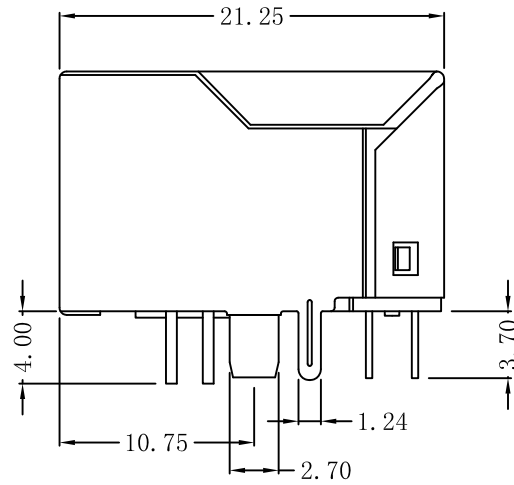
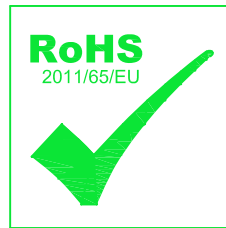

Left Side View

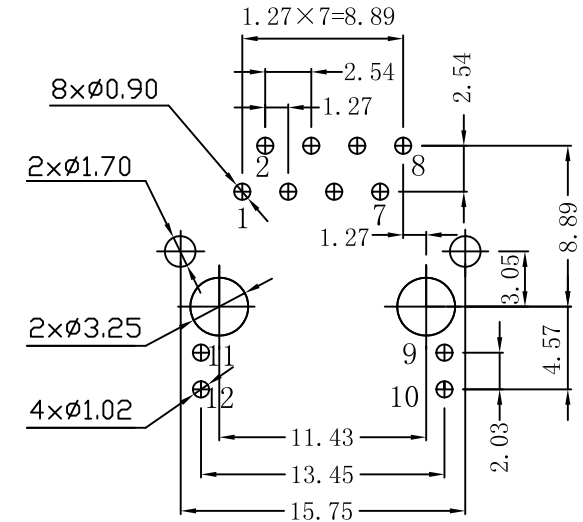

Suggested PCB Layout (Top View)

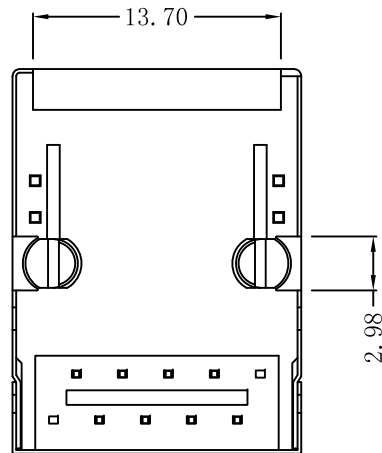

Bottom Side View



Top Side View

### NOTES:

1. Designed to support application, such as SOHO (ADSL modems), LAN-on-Motherboard (LOM), hub and Switches.
2. Meets IEEE 802.3 specification
3. Connector Materials:  
 Housing: Thermoplastic PBT+30%G.F UL94V-0  
 Contact: Phosphor Bronze C5210R-EH Thickness=0.35mm  
 Pins: Brass C2680R-H Thickness=0.35mm  
 Shield: SUS 201-1/2H Thickness=0.2mm  
 Contact plating: Gold 6 micro-inches Min. In contact area.
4. Wave solder tip temperature: 265°C Max, 5 Sec.
5. UL Certification: File Number E321120.

X:X	±0.25	APPD:	<b>Trxcom</b>
X:XX	±0.20	CHKD:	
X:XXX	±0.05	DR: SEA	TITLE: RJ45 Connector With 10/100 Base-TX Integrated Magnetic TAB-UP
ANGLES	±1°	UNIT: mm	PART NO.: TRJ16093BENL
	SCALE: 2/1	SHEET: 1/4	REV: A DWG NO: TRC09053061

# Schematic:

PC BOARD CONNECTIONS

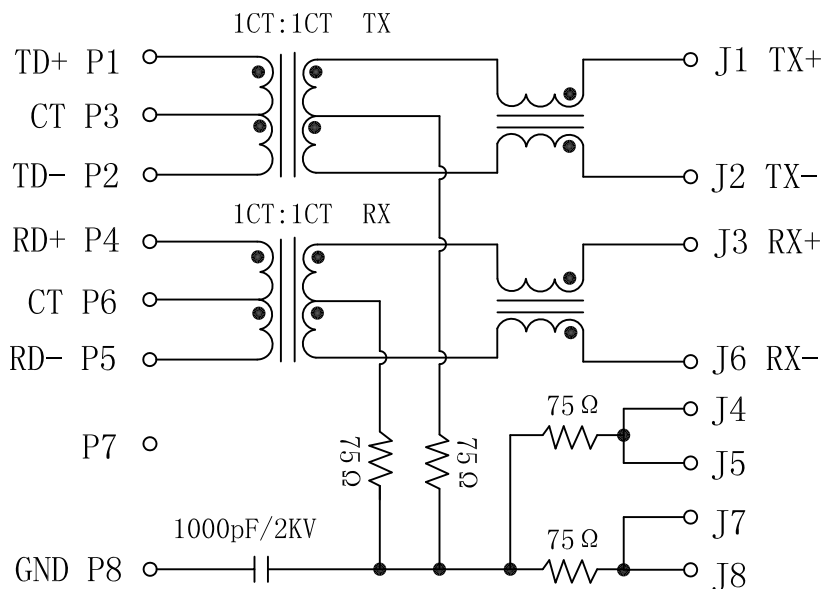

RJ45 CONNECTOR

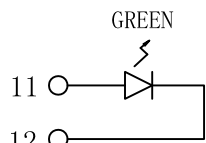

LEFT LED

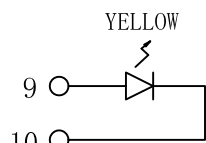

RIGHT LED

Emitting Color	$\lambda_p(\text{nm})$	$V_F@I_F=20\text{mA}$	$I_R @V_R=5V$
GREEN	565	1.8~2.6V	10 $\mu\text{A}$ max
YELLOW	585	1.8~2.6V	10 $\mu\text{A}$ max

REV.	ECN NO.	DESCRIPTION	DATE	APPD
A	REL		2009-05-30	

## Electrical Specifications:

### TEST NOTES (25±5°C)

- Turns Ratio:  
TX=1CT:1CT      RX=1CT:1CT
- Inductance: 350uH Min  
@100KHz, 0.1V, 8mA DC Bias.
- Insertion Loss:  
0.3-100MHz:-1.0dB Max
- Return Loss(dB Min):  
1-30MHz:-20;      30-60MHz:-15  
60-80MHz:-10
- Cross Talk:  
1-100MHz:-30dB Min
- Common To Common Mode Rejection:  
1-100MHz:-30dB Min
- Operating voltage: 3.3-5V Max  
Current: 350mA.
- Hi-Pot Test: 1500Vrms
- Operating Temperature: -40°C~+85°C.



X:X	±0.25	APPD:	<b>Trxcom</b>	
X:XX	±0.20	CHKD:	Huizhou Trxcom Electronics Co.,Ltd.	
X:XXX	±0.05	DR: SEA	TITLE: RJ45 Connector With 10/100 Base-TX Integrated Magnetic TAB-UP	
ANGLES	±1°	UNIT: mm	PART NO.: TRJ16093BENL	
	SCALE: 2/1	SHEET: 2/2	REV: A	DWG NO: TRC09053061

Profile of wave solder:

REV.	ECN NO.	DESCRIPTION	DATE	APPD
A	REL		2009-05-30	

SUGGESTED PROFILE OF WAVE SOLDER FOR ROHS PRODUCT

REV: A  
 TEMP(°C): 25  
 HUM(%): 65 RH

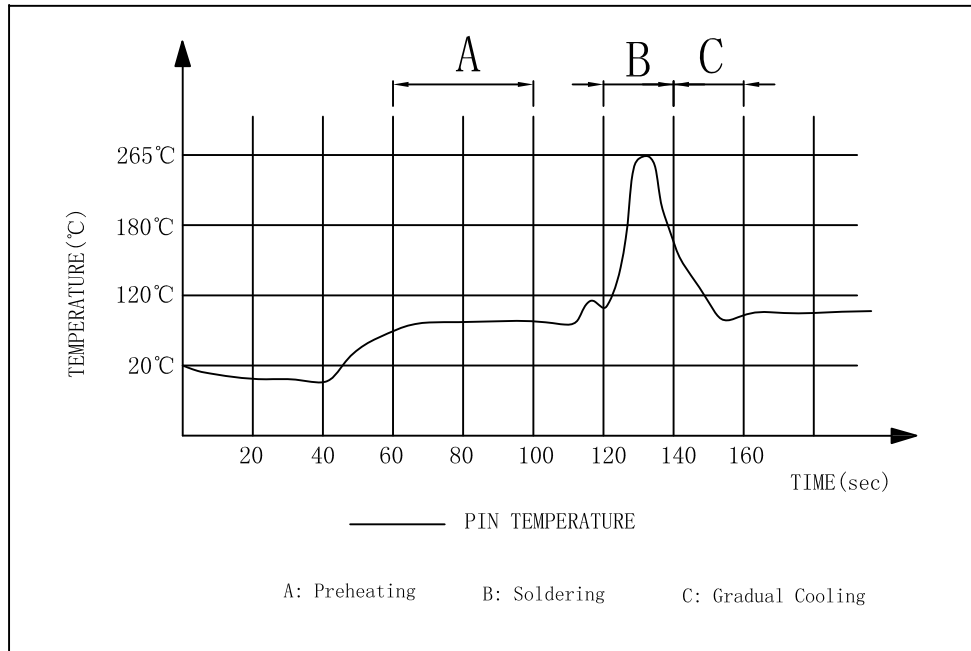

- (1) Tip Temperature: 265°C max
  - (2) Tip Temperature time: 5sec max
- Note: The melting point of Tin: 219°C

X:X ±0.25	APPD:	<b>Trxcom</b> Huizhou Trxcom Electronics Co.,Ltd.
X:XX ±0.20	CHKD:	
X:XXX ±0.05	DR: SEA	TITLE: RJ45 Connector with 10/100 Base-T Integrated Magnetics
ANGLES ±1°	UNIT: mm	PART NO.: TRJ16093BENL
	SCALE: 2/1	SHEET: 3/4
	REV: A	DWG NO.: TRC09053061

Packaging:

REV.	ECN NO.	DESCRIPTION	DATE	APPD
A	REL		2009-05-30	

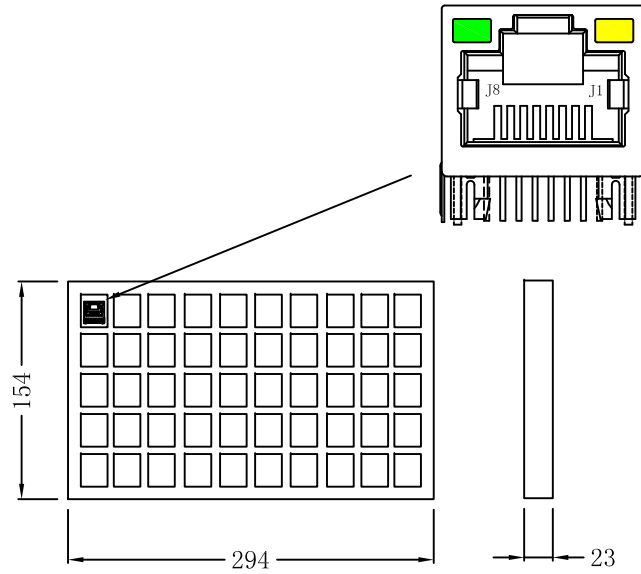

24Tray →

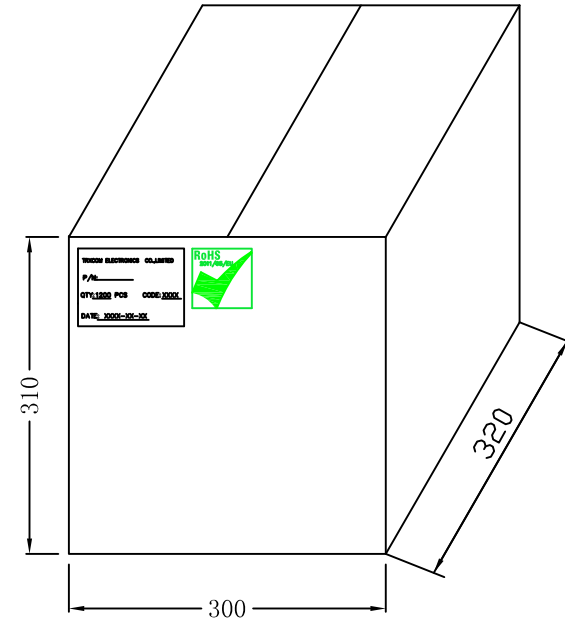

- ◆ Packaging unit :50pcs/tray
- ◆ Packaging material:PVC
- ◆ Outer carton unit:1200pcs/24tray/box
- ◆ Net Weight:8kg
- ◆ Gross Weight:10kg

X:X ±0.25	APPD:	<b>Trxcom</b> Huizhou Trxcom Electronics Co.,Ltd.
X:XX ±0.20	CHKD:	
X:XXX ±0.05	DR: SEA	TITLE: 1*1 21.3 RJ45 PACKING
ANGLES ±1°	UNIT: mm	PART NO.: TRJ16093BENL
	SCALE: 2/1	SHEET: 4/4
	REV: A	DWG NO.: TRC09053061