

Mechanical:

REV.	ECN NO.	DESCRIPTION	DATE	APPD
A	REL		2010-04-15	

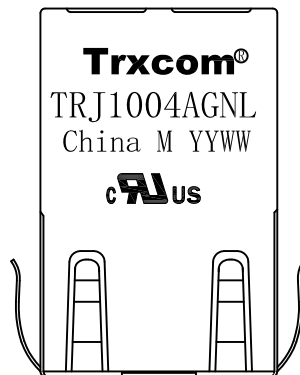
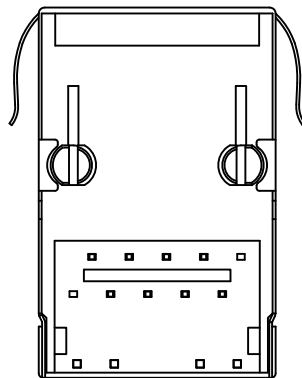
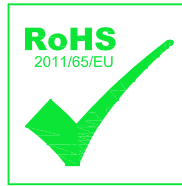
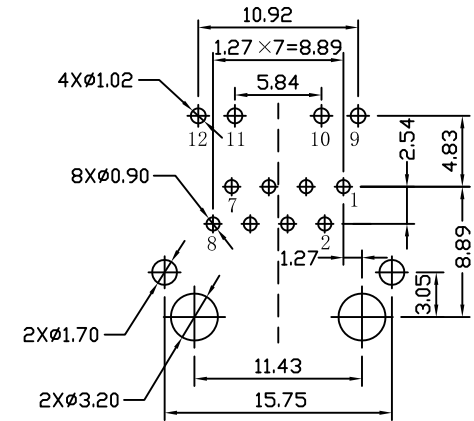
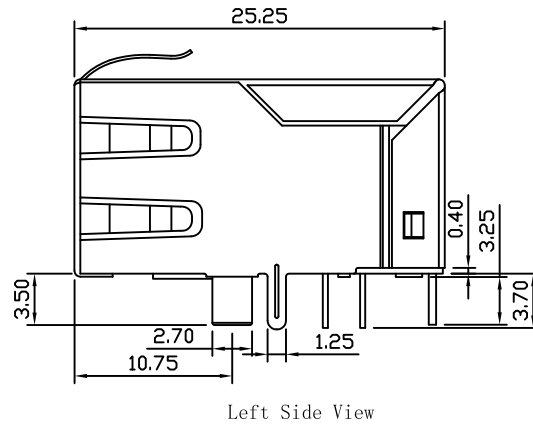
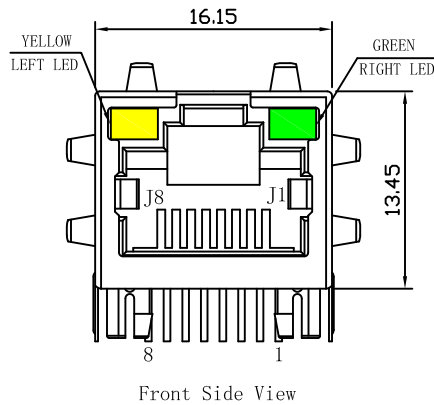

NOTES:

1. Designed to support application, such as SOHO (ADSL modems), LAN-on-Motherboard (LOM), hub and Switches.
2. Meets IEEE 802.3 specification
3. Connector Materials:
 Housing: Thermoplastic PBT+30%G.F UL94V-0
 Contact: Phosphor Bronze C5210R-EH Thickness=0.35mm
 Pins: Brass C2680R-H Thickness=0.35mm
 Shield: SUS 201-1/2H Thickness=0.2mm
 Contact plating: Gold 6 micro-inches min. In contact area.
4. Operating Voltage: 3.3V-5V MAX. Current: 350mA.
5. Wave solder tip temperature: 265°C Max, 5 Sec Max.
6. UL Certification: File Number E321120.

X:X ±0.25	APPD:	Trxcom Huizhou Trxcom Electronics Co., Ltd
X:XX ±0.20	CHKD:	
X:XXX ±0.05	DR: SEA	TITLE: RJ45 Connector with 10/100 Base-T Integrated Magnetics
ANGLES ±1°	UNIT: mm	PART NO.: TRJ1004AGNL
	SCALE: 2/1	SHEET: 1/4
	REV: A	DWG NO.: LP10041526

Schematic:

REV.	ECN NO.	DESCRIPTION	DATE	APPD
A	REL		2010-04-15	

PC BOARD CONNECTIONS

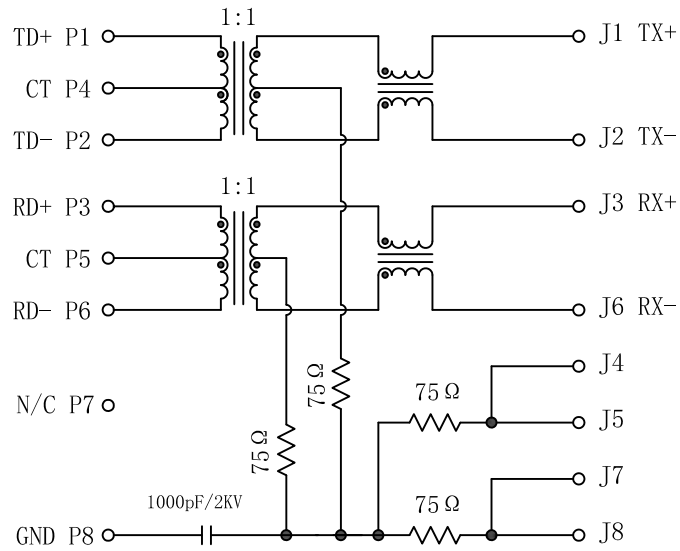

RJ45 CONNECTOR

ELECTRICAL SPECIFICATIONS @25°C

- Turn Ratio ($\pm 3\%$):
 (P1-P2) : (J1-J2) = 1CT:1CT
 (P3-P6) : (J3-J6) = 1CT:1CT
- OCL (@100KHz, 0.1Vrms, 8mA):
 (P1-P2, P3-P6) : 350uH MIN
- Insertion Loss:
 -1.1dB MAX @0.1-100MHz
- Return Loss:
 -18dB MIN @0.5-30MHz
 -15.5dB MIN @40MHz
 -13.6dB MIN @50MHz
 -12dB MIN @60-80MHz
- Cross talk:
 -40dB TYP @1-100MHz
- Common Mode Rejection:
 -50dB TYP @0.1-30MHz
 -40dB TYP @30-60MHz
 -35dB TYP @60-100MHz
- Isolation: 1500Vrms
- Operating Temperature: 0°C TO 70°C.

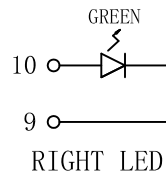
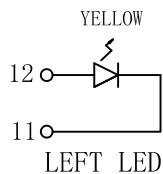

Emitting Color	λ p(nm)	VF@IF=20mA	IR @VR=5V
GREEN	565	1.8~2.6V	10 μ A max
YELLOW	585	1.8~2.6V	10 μ A max

X:X	± 0.25	APPD:	Trxcom	
X:XX	± 0.20	CHKD:	Huizhou Trxcom Electronics Co., Ltd	
X:XXX	± 0.05	DR: SEA	TITLE: RJ45 Connector with 10/100 Base-T Integrated Magnetics	
ANGLES	$\pm 1^\circ$	UNIT: mm	PART NO.: TRJ1004AGNL	
	SCALE: 2/1	SHEET: 2/4	REV: A	DWG NO.: LP10041526

Profile of wave solder:

REV.	ECN NO.	DESCRIPTION	DATE	APPD
A	REL		2015-06-11	

SUGGESTED PROFILE OF WAVE SOLDER FOR ROHS PRODUCT

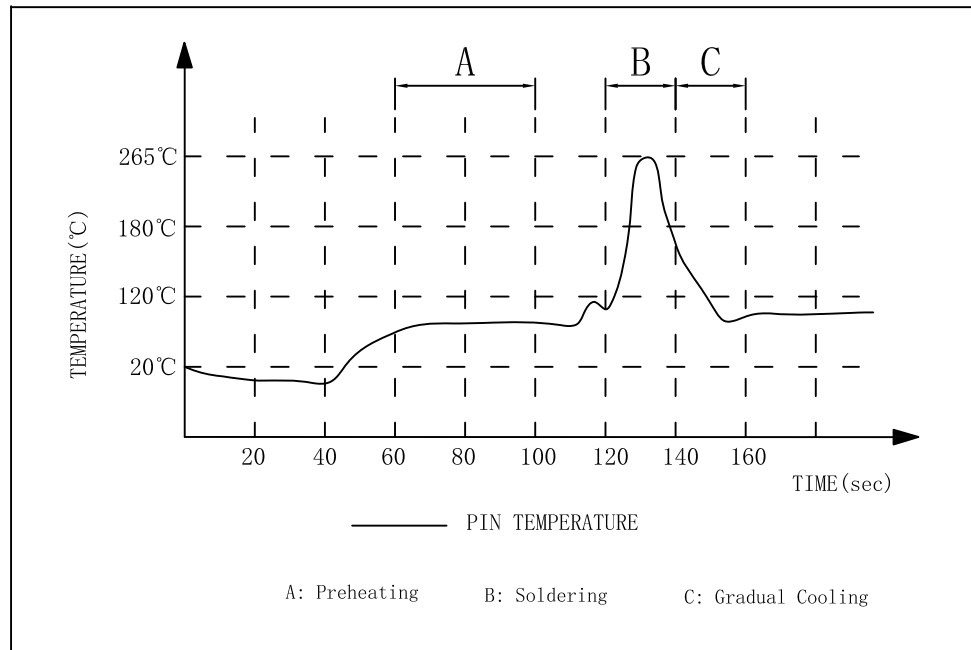

- (1) Tip Temperature: 265°C max
 - (2) Tip Temperature time: 5sec max
- Note: The melting point of Tin: 219°C

X:X ±0.25	APPD:	Trxcom Huizhou Trxcom Electronics Co.,Ltd
X:XX ±0.20	CHKD:	
X:XXX ±0.05	DR: SEA	TITLE: RJ45 Connector with 10/100 Base-T Integrated Magnetics
ANGLES ±1°	UNIT: mm	PART NO.: TRJ1004AGNL
	SCALE: 2/1	SHEET: 3/4
	REV: A	DWG NO.: LP10041526

Packaging:

REV.	ECN NO.	DESCRIPTION	DATE	APPD
A	REL		2015-06-11	

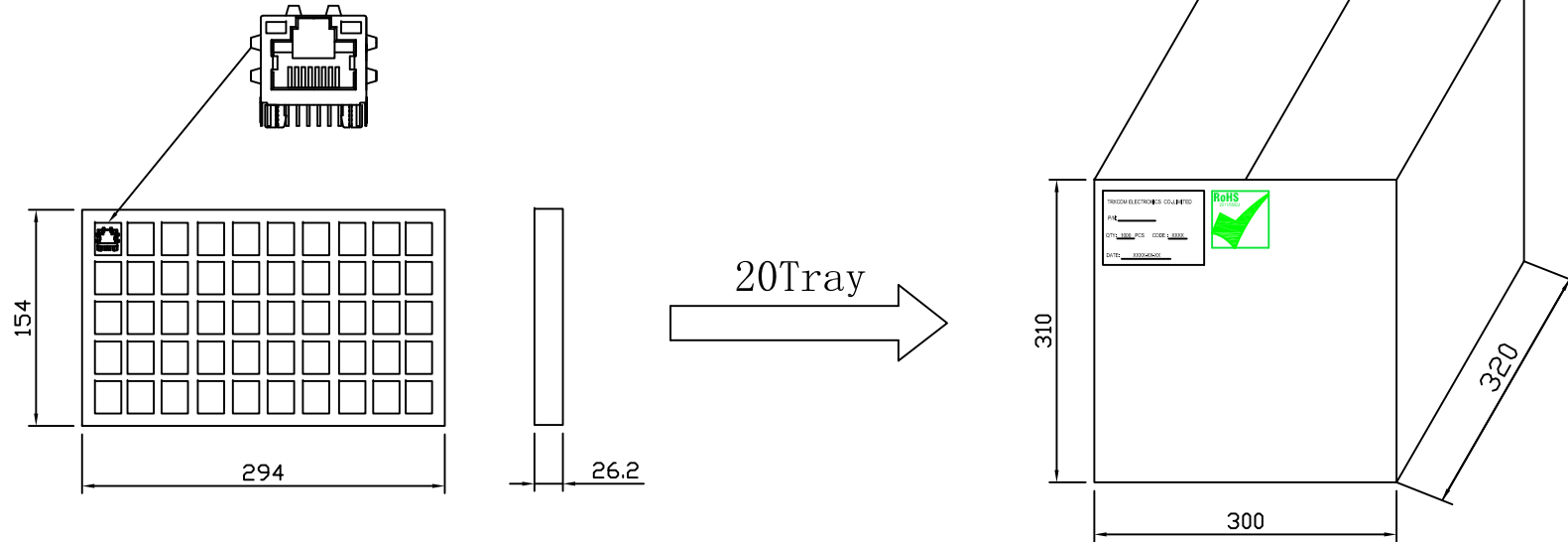

- ◆ Packaging unit :50pcs/tray
- ◆ Packaging material:PVC
- ◆ Outer carton unit:1000pcs/20tray/box
- ◆ Net Weight:7kg
- ◆ Gross Weight:9kg

X:X	±0.25	APPD:	Trxcom Huizhou Trxcom Electronics Co.,Ltd		
X:XX	±0.20	CHKD:			
X:XXX	±0.05	DR: SEA	TITLE: 1*1 25.4 RJ45 PACKING		
ANGLES	±1°	UNIT: mm	PART NO. : TRJ1004AGNL		
		SCALE: 2/1	SHEET: 4/4	REV: A	DWG NO. : LP10041526