

Mechanical:

REV.	ECN NO.	DESCRIPTION	DATE	APPD
A	REL		2012-04-26	

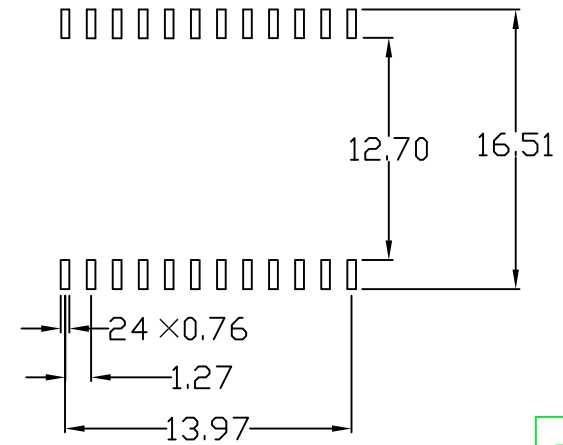

SUGGESTED PAD LAYOUT

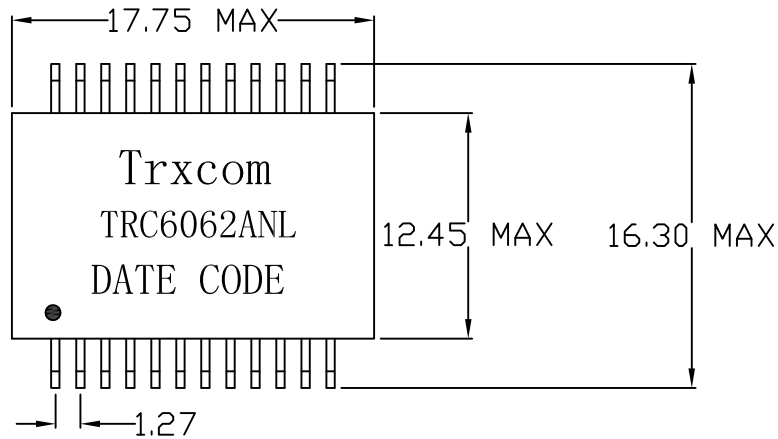
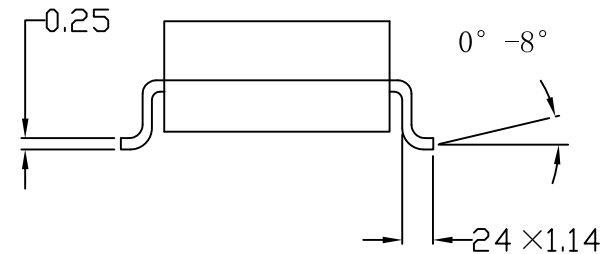
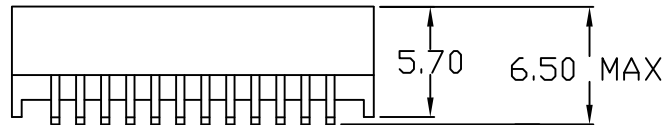

NOTES:

1. Designed to support application, such as SOHO (ADSL modems), LAN-on-Motherboard (LOM), hub and Switches.
2. Meets IEEE 802.3af specification.
3. Maximum reflow temperature is 250°C, 5 Sec.
4. UL Certification: File Number E321120.

X:X	APPD:	Trxcom TRXCOM INT'L TECHNOLOGY CO. LTD.
X:XX ±0.25	CHKD:	
X:XXX	DR: SEA	TITLE: 1000Base-T Single Port Transformer Modules For PoE Application
ANGLES ±1°	UNIT: mm	PART NO.: TRC6062ANL
	SCALE: 2/1	SHEET: 1/4
	REV: A	DWG NO.: TRC12042631

Schematic:

REV.	ECN NO.	DESCRIPTION	DATE	APPD
A	REL		2012-04-26	

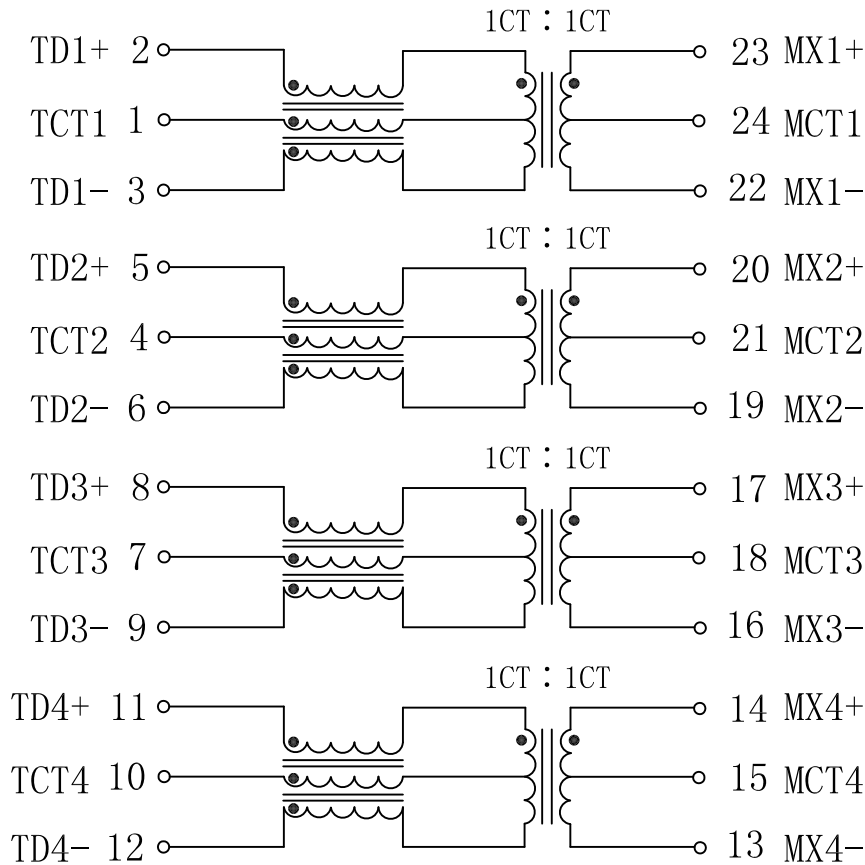

ELECTRICAL SPECIFICATIONS @25°C

- Turn Ratio($\pm 3\%$):
Pri : Sec = 1CT : 1CT
- Inductance OCL:
350uH MIN @100KHz 0.1V 8mA DC Bias
- Insertion Loss:
-1.1dB MAX @1-100MHz
- Return Loss:
-16dB MIN @1-30MHz
-12dB MIN @30-60MHz
-10dB MIN @60-100MHz
- Cross talk:
-40dB MIN @1-30MHz
-35dB MIN @30-60MHz
-30dB MIN @60-100MHz
- Common Mode Rejection:
-30dB MIN @1-50MHz
-20dB MIN @50-150MHz
- Balanced DC Line current:
350mA MAX @57V DC Continuous.
- Hipot Test: 1500Vrms
- Operating Temperature Range: $-40^{\circ}\text{C} \sim +85^{\circ}\text{C}$.

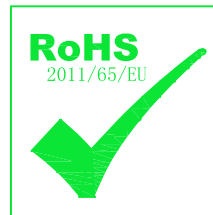

X:X	APPD:	Trxcom	
X:XX ±0.25	CHKD:	TRXCOM INT'L TECHNOLOGY CO. LTD.	
X:XXX	DR: SEA	TITLE: 1000Base-T Single Port Transformer Modules For PoE Application	
ANGLES ±1°	UNIT: mm	PART NO.: TRC6062ANL	
	SCALE: 2/1	SHEET: 2/4	REV: A DWG NO.: TRC12042631

IR Reflow:

REV.	ECN NO.	DESCRIPTION	DATE	APPD
A	REL		2012-04-26	

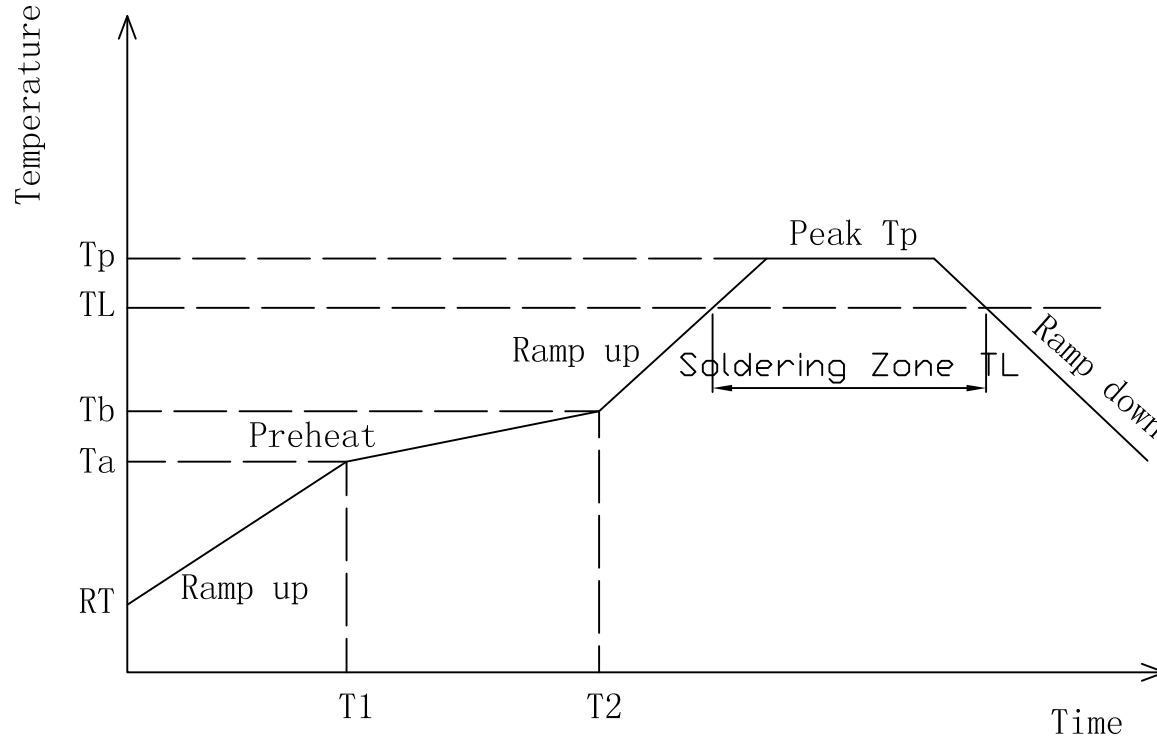

- ◆ Preheat:
Temperature (Ta-Tb) : 150-200°C
Time (t1-t2) : 60-180s
- ◆ Holding Temperature: 217°C
Time (TL) : 60-150s
- ◆ Max Temperature (Tp) : 250 (+0/-5°C)
Max Time (Tp) : 30s
- ◆ The average speed: 3°C/S Max
The average cooling speed: 6°C/S Max
- ◆ From 25°C to Products out of the furnace: 6 minutes Max

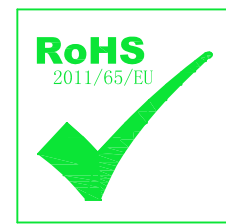

X:X	APPD:	Trxcom TRXCOM INT'L TECHNOLOGY CO. LTD.
X:XX ±0.25	CHKD:	
X:XXX	DR: SEA	
ANGLES ±1°	UNIT: mm	TITLE: 1000Base-T Single Port Transformer Modules For PoE Application
		PART NO. : TRC6062ANL
	SCALE: 2/1	SHEET: 3/4
	REV: A	DWG NO. : TRC12042631

Packing:

REV.	ECN NO.	DESCRIPTION	DATE	APPD
B	REL		2012-04-26	

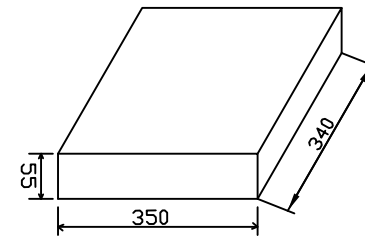
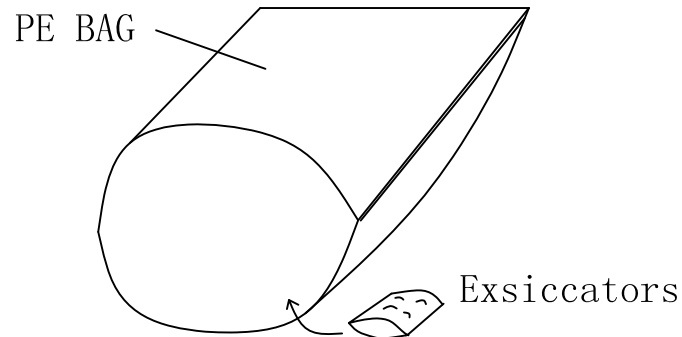
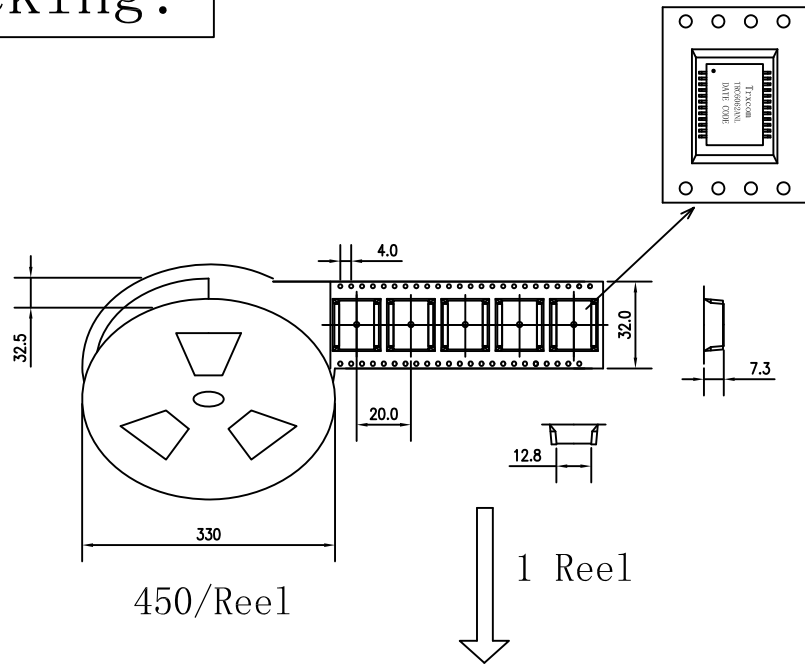

6 Inner Carton

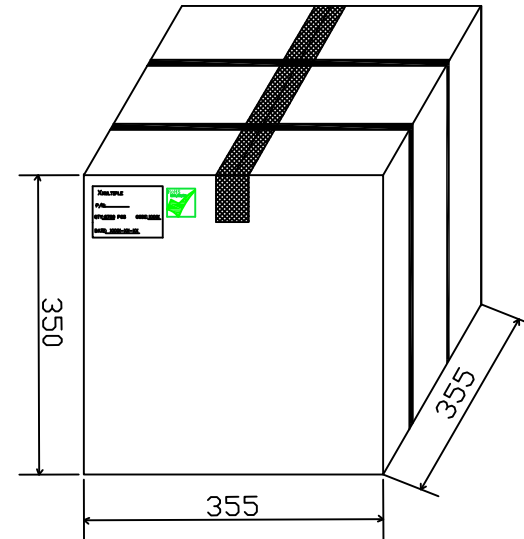

- ◆ Packaging unit: 450pcs/reel
- ◆ Packaging way: Carrier tape
- ◆ Outer carton unit: 2700pcs/6 Inner Carton/box
- ◆ Net Weight: 10kg
- ◆ Gross Weight: 13 kg

X:X	APPD:	Trxcom TRXCOM INT'L TECHNOLOGY CO. LTD.
X:XX ±0.25	CHKD:	
X:XXX	DR: SEA	TITLE: 1000Base-T Single Port Transformer Modules For PoE Application
ANGLES ±1°	UNIT: mm	PART NO. : TRC6062ANL
	SCALE: 2/1	SHEET: 4/4
	REV: A	DWG NO. : TRC12042631