

Mechanical :

REV.	ECN NO.	DESCRIPTION	DATE	APPD
A	REL		2015-05-21	

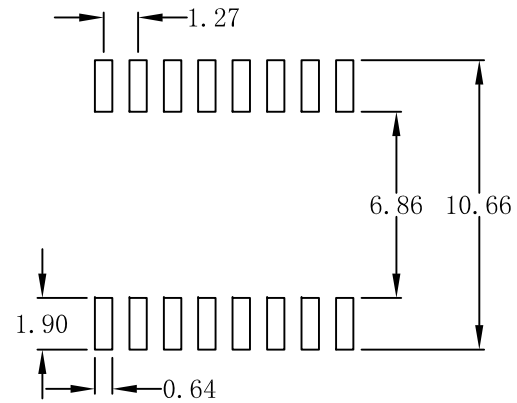

SUGGESTED PAD LAYOUT

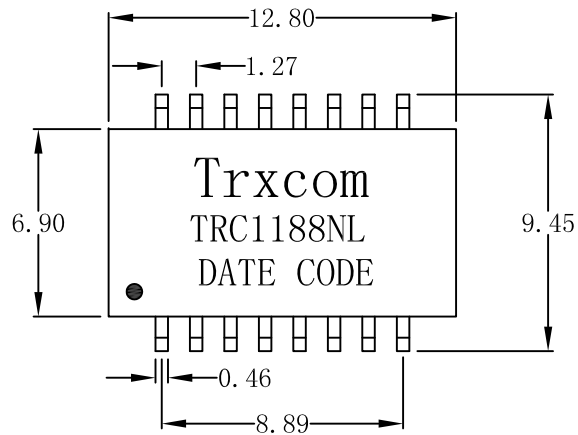
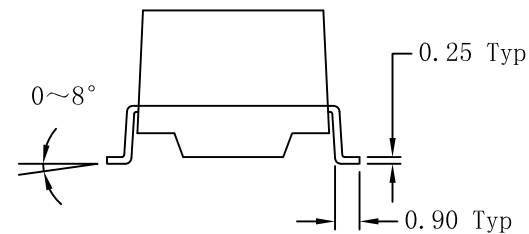
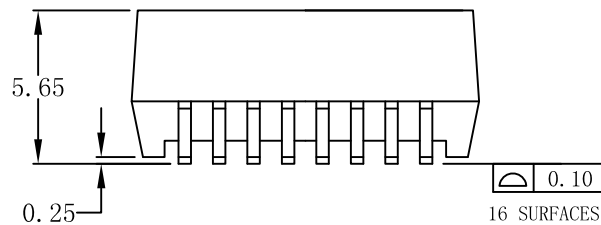

NOTES:

1. Designed to support application, such as SOHO (ADSL modems), LAN-on-Motherboard (LOM), hub and Switches.
2. Meets IEEE 802.3 specification.
3. Maximum reflow temperature is 250°C, 5 Sec.
4. UL certification: file number E321120

X:X	APPD:	Trxcom		
X:XX ±0.25	CHKD:	Huizhou Trxcom Electronics Co., Ltd.		
X:XXX	DR: SEA	TITLE: 10/100Base-T Single Port Transformer Modules		
ANGLES ±1°	UNIT: mm	PART NO.: TRC1188NL		
	SCALE: 2/1	SHEET: 1/4	REV: A	DWG NO.: TRC15052188

Schematic:

REV.	ECN NO.	DESCRIPTION	DATE	APPD
A	REL		2015-05-21	

CHIP SIDE

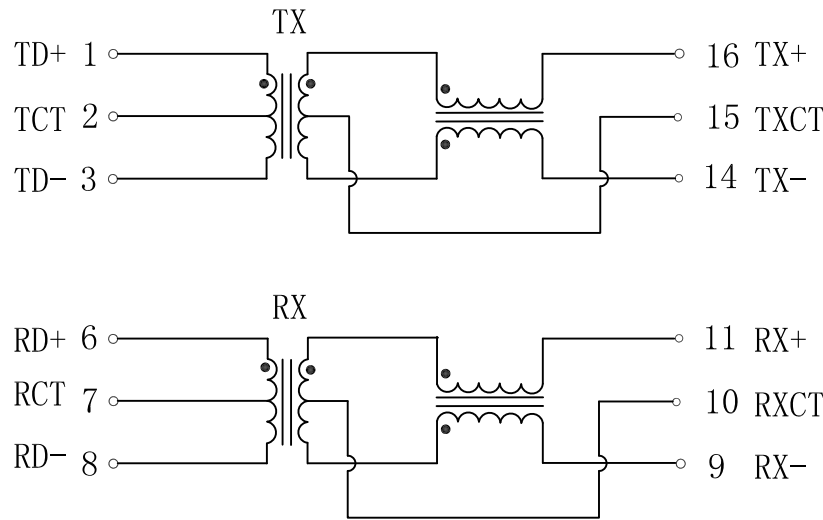

LINE SIDE

Electrical Specifications @25°C

- Inductance PIN(1-3), (6-8): 350uH MIN
@100KHz, 0.1V, 8mA DC
- Leak Inductance: 0.50uH MAX
@1MHz, 0.02V, chip side with line side shorted
- Interwinding Capacitance: 30pF MAX
@1MHz, 0.02V, from chip side to line side
- DCR:
PIN(1-3), (6-8): 1.10 Ω MAX
- Turns Ratio(±3%):
TX=1CT : 1CT RX=1CT : 1CT
- Insertion Loss:
1-100MHz:-1.1dB MAX
- Return Loss(dB MIN @100 Ω):
1-30MHz:-16
30-60MHz:-12
60-100MHz:-10
- Crosstalk(dB MIN):
1-30MHz:-40
30-60MHz:-35
60-100MHz:-30
- Common Mode Rejection(dB MIN):
1-50MHz:-30
50-150MHz:-20
- Hipot:
1500Vrms/3sec, from chip side to line side
- Operating Temperature: -40°C ~+85°C.
- Rated power: 10VA max

RoHS
2011/65/EU



X:X	APPD:	Trxcom		
X:XX ±0.25	CHKD:	Huizhou Trxcom Electronics Co., Ltd.		
X:XXX	DR: SEA	TITLE: 10/100Base-T Single Port Transformer Modules		
ANGLES ±1°	UNIT: mm	PART NO.: TRC1188NL		
	SCALE: 2/1	SHEET: 2/4	REV: A	DWG NO.: TRC15052188

IR Reflow:

REV.	ECN NO.	DESCRIPTION	DATE	APPD
A	REL		2015-05-21	

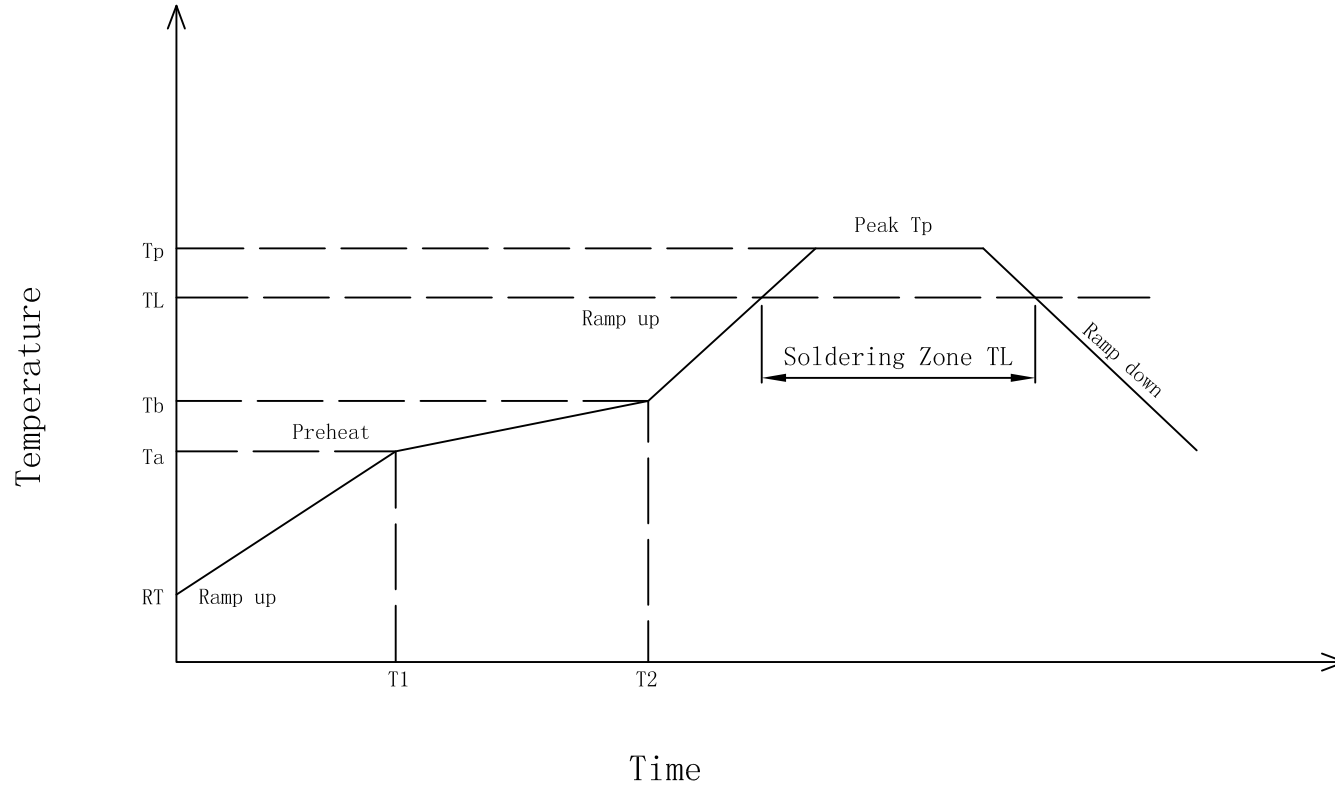

Preheat:
 Temperature (Ta-Tb) : 150-200°C
 Time (T1-T2) : 60-180s

Holding Temperature: 217°C
 Time (TL) : 60-150s

Max Temperature (Tp) : 250 (+0/-5°C)
 Max Time (Tp) : 30s

The average speed: 3°C/S Max
 The average cooling speed: 6°C/S Max

From 25°C to Products out of the furnace: 6 minutes Max



X:X	APPD:	Trxcom
X:XX ±0.25	CHKD:	
X:XXX	DR: SEA	TITLE: 10/100Base-T Single Port Transformer Modules
ANGLES ±1°	UNIT: mm	PART NO.: TRC1188NL
	SCALE: 2/1	SHEET: 3/4
	REV: A	DWG NO.: TRC15052188

Packing:

REV.	ECN NO.	DESCRIPTION	DATE	APPD
B	REL		2015-05-25	

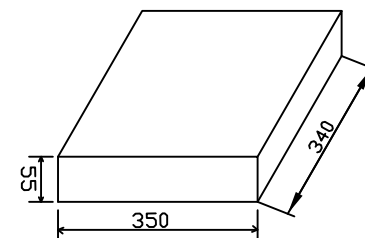
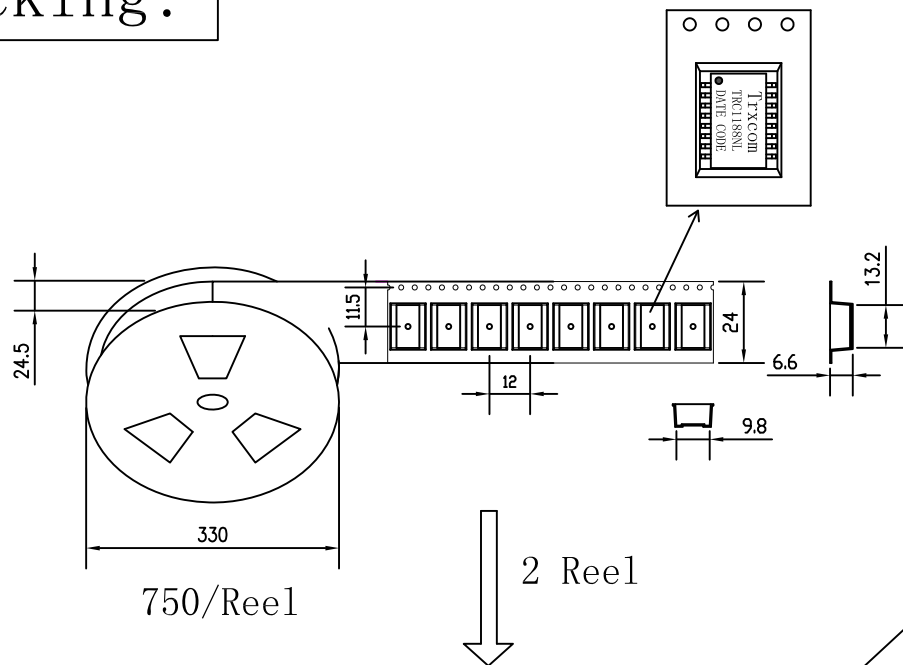

5 Inner Carton

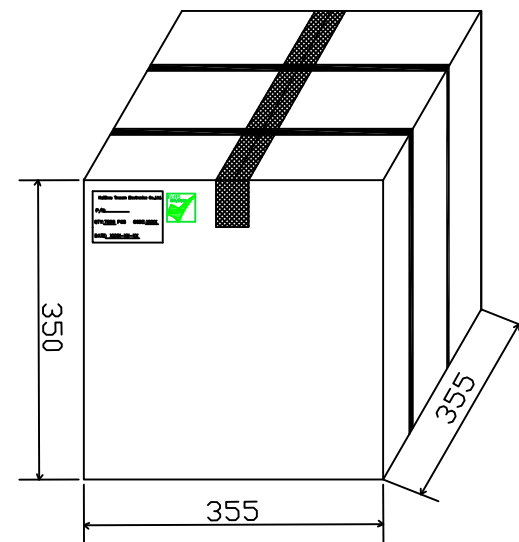
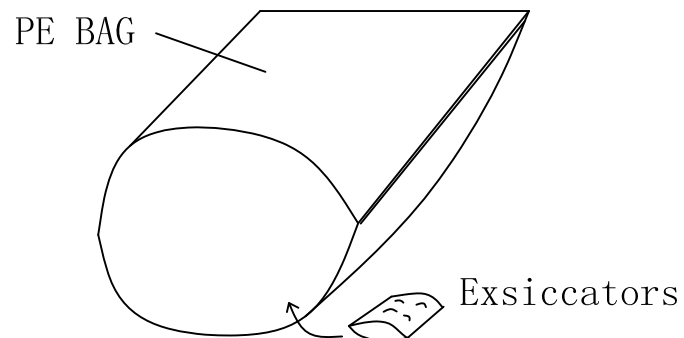

- ◆ Packaging unit : 750 pcs/ reel
- ◆ Packaging way : Carrier tape
- ◆ Outer carton unit : 7500 pcs/5 Inner Carton/box
- ◆ Net Weight : 4.5 kg
- ◆ Gross Weight : 9 kg

X:X	APPD:	Trxcom Huizhou Trxcom Electronics Co.,Ltd.
X:XX ±0.25	CHKD:	
X:XXX	DR: SEA	TITLE: 16 pins 12.80mm SMT transformer
ANGLES ±1°	UNIT: mm	PART NO. : TRC1188NL
	SCALE: 2/1	SHEET: 4/4
	REV: A	DWG NO. : TRC15052188