

# Mechanical :

REV.	ECN NO.	DESCRIPTION	DATE	APPD
A	REL		2015-06-09	

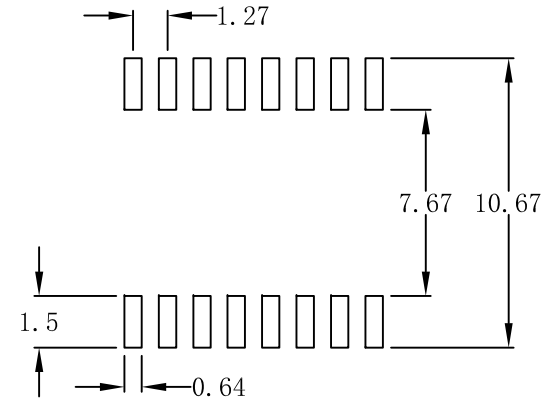

SUGGESTED PAD LAYOUT

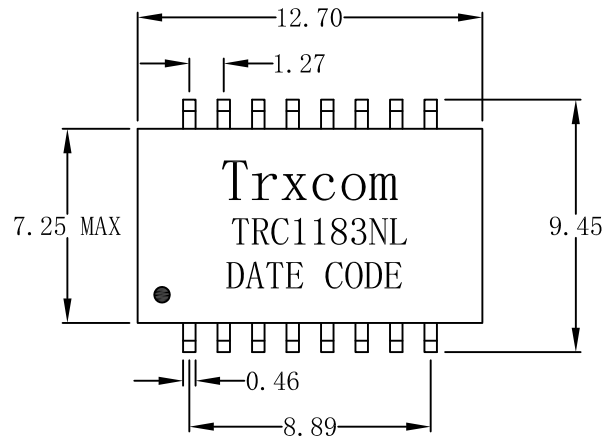
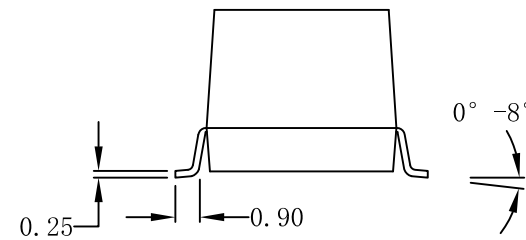
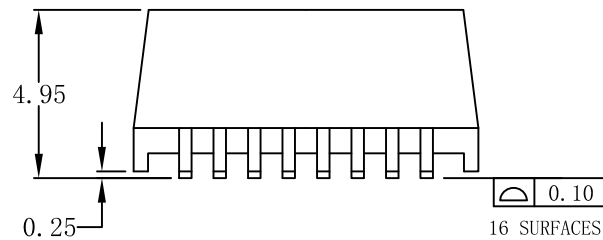

## NOTES:

1. Designed to support application, such as SOHO (ADSL modems), LAN-on-Motherboard (LOM), hub and Switches.
2. Meets IEEE 802.3 specification.
3. Maximun reflow temperature is 250°C, 5 Sec.
4. UL certification: file number E321120

X:X	APPD:	<b>Trxcom</b>		
X:XX ±0.25	CHKD:	Huizhou Trxcom Electronics Co.,Ltd		
X:XXX	DR: SEA	TITLE: 10/100Base-T Single Port Transformer Modules		
ANGLES ±1°	UNIT: mm	PART NO.: TRC1183NL		
	SCALE: 2/1	SHEET: 1/4	REV: A	DWG NO.: TRC10011912

# Schematic:

REV.	ECN NO.	DESCRIPTION	DATE	APPD
A	REL		2015-06-09	

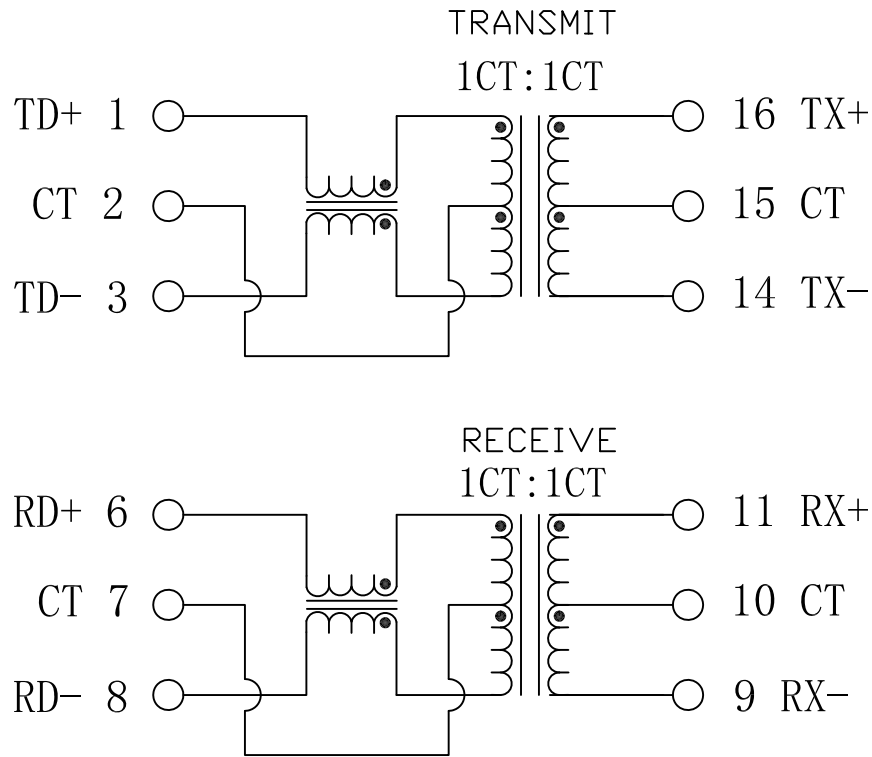

## ELECTRICAL SPECIFICATIONS @25°C

- Turn Ratio( $\pm 3\%$ ):  
TX=1CT:1CT      RX=1CT:1CT
- Inductance OCL:  
350uH MIN @ 100KHz 0.1V 8mA DC Bias
- Insertion Loss:  
-1.0dB MAX @ 1-100MHz
- Return Loss:  
-18dB TYP @ 1-30MHz  
-14dB TYP @ 30-60MHz  
-12dB TYP @ 60-100MHz
- Cross talk:  
-35dB TYP @ 1-30MHz  
-35dB TYP @ 30-60MHz  
-35dB TYP @ 60-100MHz
- Common Mode Rejection:  
-40dB TYP @ 1-30MHz  
-40dB TYP @ 30-50MHz  
-40dB TYP @ 50-100MHz
- Hipot Test: 1500Vrms
- Operating Temperature Range: 0°C TO 70°C



X:X	APPD:	<b>Trxcom</b>		
X:XX ±0.25	CHKD:	Huizhou Trxcom Electronics Co.,Ltd		
X:XXX	DR: SEA	TITLE: 10/100Base-T Single Port Transformer Modules		
ANGLES ±1°	UNIT: mm	PART NO.: TRC1183NL		
	SCALE: 2/1	SHEET: 1/4	REV: A	DWG NO.: TRC10011912

# IR Reflow:

REV.	ECN NO.	DESCRIPTION	DATE	APPD
A	REL		2015-06-09	

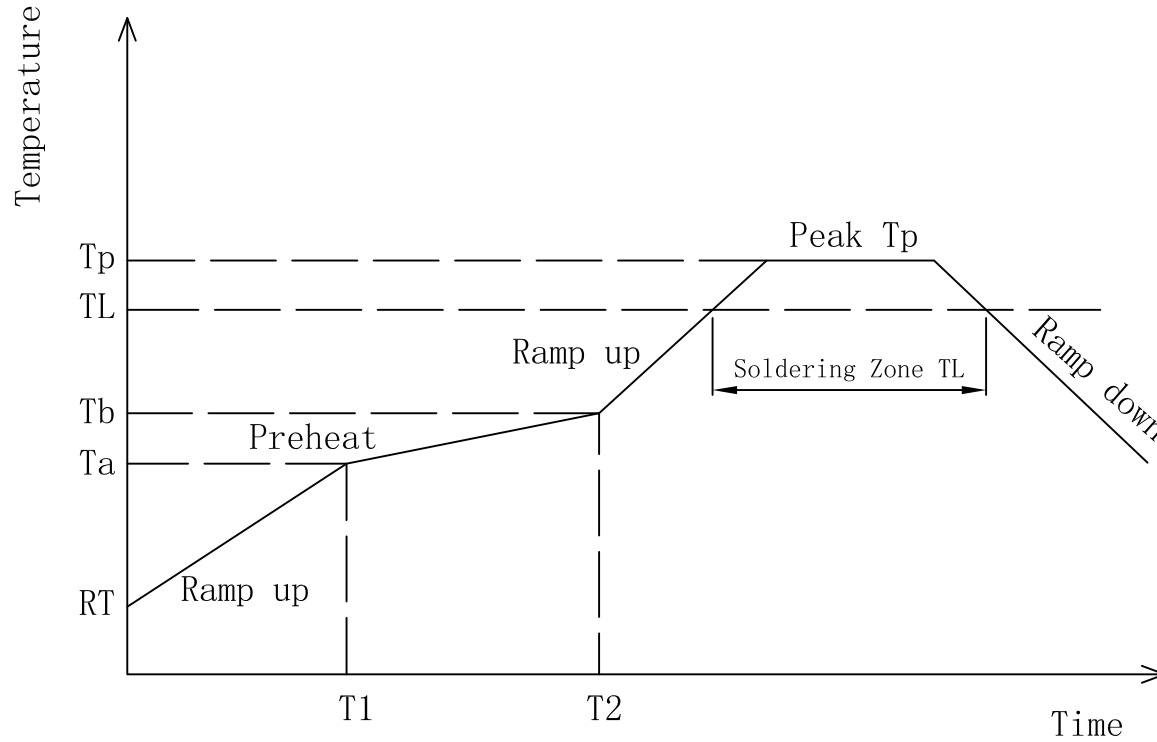

- ◆ Preheat:  
Temperature (Ta-Tb) : 150-200°C  
Time (t1-t2) : 60-180s
- ◆ Holding Temperature: 217°C  
Time (TL) : 60-150s
- ◆ Max Temperature (Tp) : 250 (+0/-5°C)  
Max Time (Tp) : 30s
- ◆ The average speed: 3°C/S Max  
The average cooling speed: 6°C/S Max
- ◆ From 25°C to Products out of the furnace: 6 minutes Max



X:X	APPD:	<b>Trxcom</b>		
X:XX ±0.25	CHKD:	Huizhou Trxcom Electronics Co.,Ltd		
X:XXX	DR: SEA	TITLE: 10/100Base-T Single Port Transformer Modules		
ANGLES ±1°	UNIT: mm	PART NO.: TRC1183NL		
	SCALE: 2/1	SHEET: 1/4	REV: A	DWG NO.: TRC10011912

# Packing:

REV.	ECN NO.	DESCRIPTION	DATE	APPD
A	REL		2015-06-09	

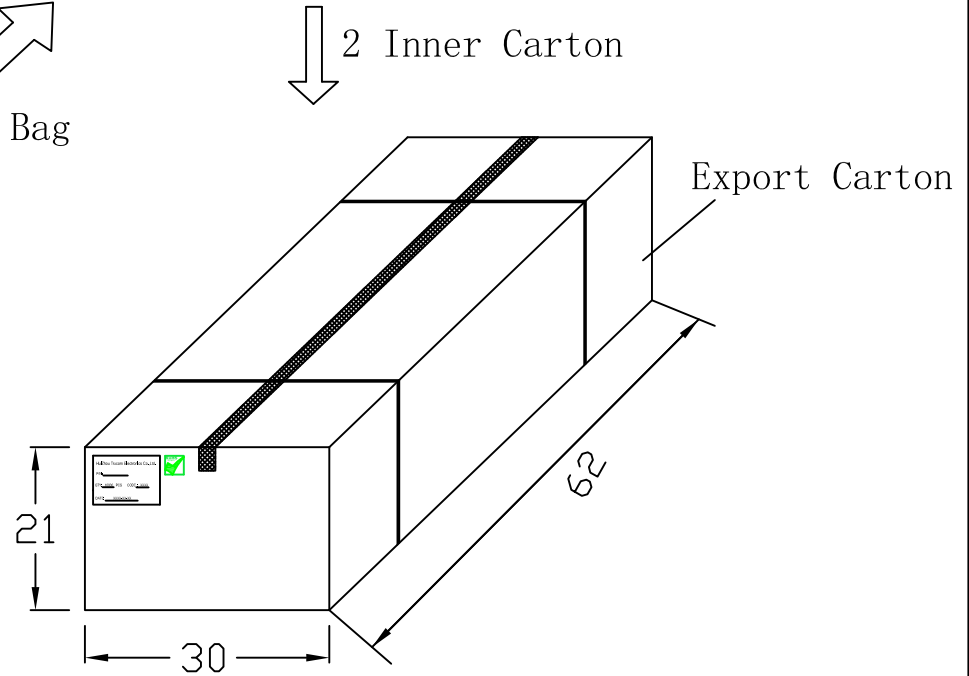
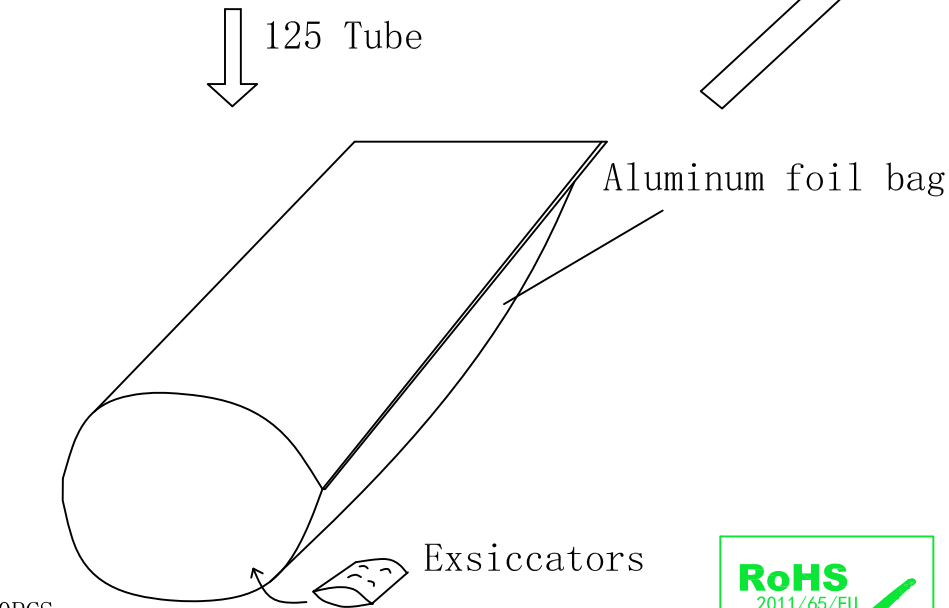
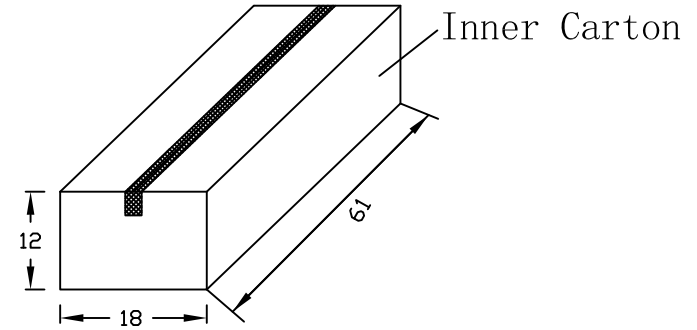
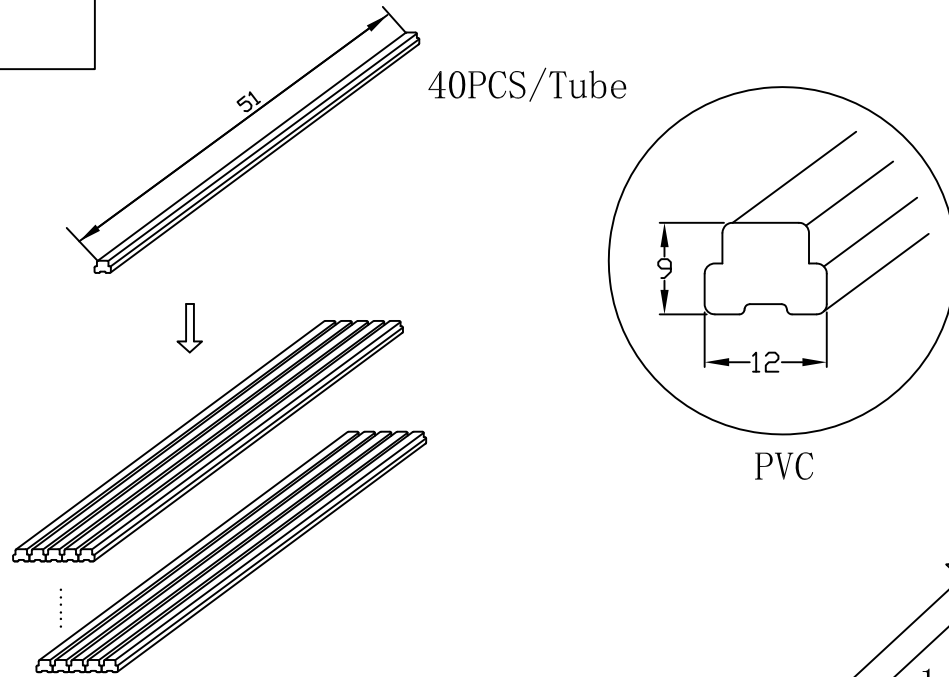

- ◆ 1 Tube = 40PCS
- ◆ 1 Inner Carton = 125Tube =5000PCS
- ◆ 1 Export Carton = 2 Inner Carton =10000PCS
- ◆ Net Weight: 10kg
- ◆ Gross Weight: 17kg



X:X	APPD:	<b>Trxcom</b>		
X:XX ±0.25	CHKD:	Huizhou Trxcom Electronics Co.,Ltd		
X:XXX	DR: SEA	TITLE: 10/100Base-T Single Port Transformer Modules		
ANGLES ±1°	UNIT: mm	PART NO.: TRC1183NL		
	SCALE: 2/1	SHEET: 1/4	REV: A	DWG NO.: TRC10011912