

Mechanical:

REV.	ECN NO.	DESCRIPTION	DATE	APPD
B	REL		2015-05-25	

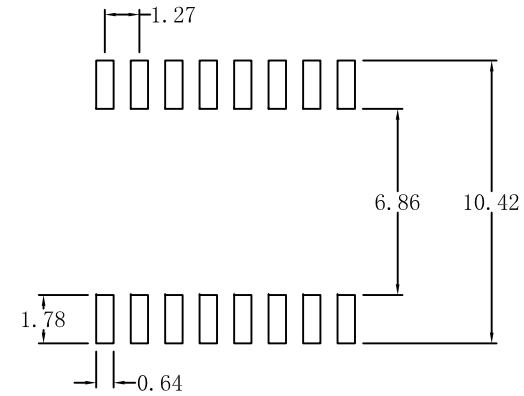

SUGGESTED PAD LAYOUT

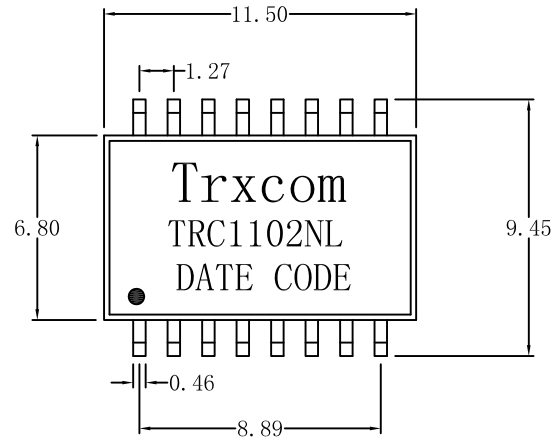
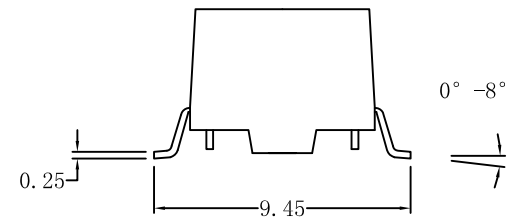
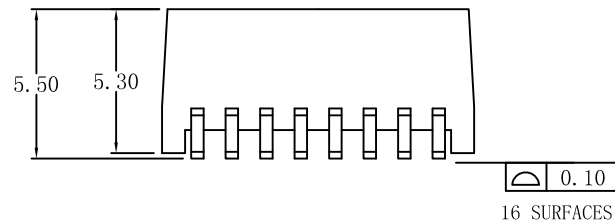

NOTES:

1. Designed to support application, such as SOHO (ADSL modems), LAN-on-Motherboard (LOM), hub and Switches.
2. Meets IEEE 802.3 specification.
3. Maximum reflow temperature is 250°C, 5 Sec.
4. UL certification: file number E321120

X:X	APPD:	Trxcom		
X:XX ±0.20	CHKD:	HuiZhou Trxcom Electronics Co., Ltd.		
X:XXX	DR: GRANT	Title: 10/100Base-T Single Port Transformer Modules		
ANGLES ±1°	UNIT: mm	PART NO.: TRC1102NL		
	SCALE: 2/1	SHEET: 1/4	REV: A	DWG NO.: TRC14032601

Schematic:

REV.	ECN NO.	DESCRIPTION	DATE	APPD
B	REL		2015-05-25	

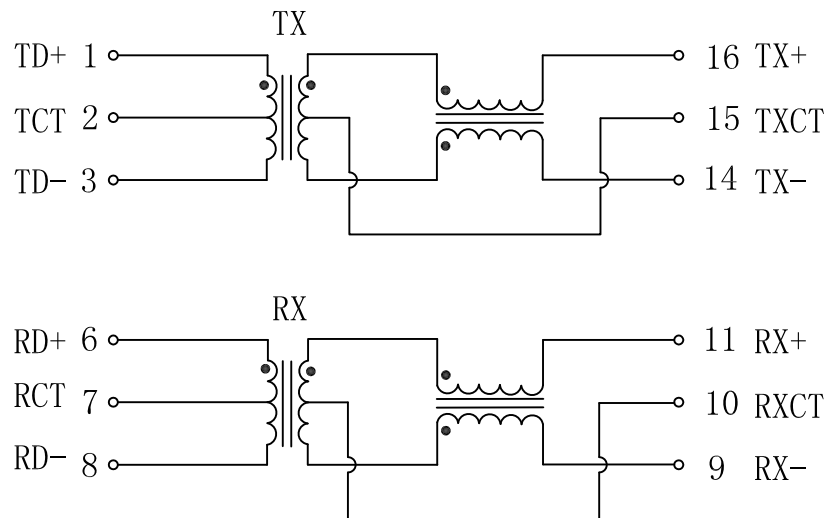

ELECTRICAL SPECIFICATIONS @25°C

- Turn Ratio($\pm 3\%$):
TX=1CT:1CT RX=1CT:1CT
- Inductance OCL:
350uH MIN @ 100KHz 0.1V 8mA DC Bias
- Insertion Loss:
-1.1dB MAX @ 1-100MHz
- Return Loss:
-16dB MIN @ 1-30MHz
-12dB MIN @ 30-60MHz
-10dB MIN @ 60-100MHz
- Cross talk:
-40dB MIN @ 1-30MHz
-35dB MIN @ 30-60MHz
-30dB MIN @ 60-100MHz
- Common Mode Rejection:
-30dB MIN @ 1-50MHz
-20dB MIN @ 50-150MHz
- Hipot Test:1500Vrms
- Operating Temperature Range: 0°C TO 70°C



X:X	APPD:	Trxcom		
X:XX ± 0.20	CHKD:	HuiZhou Trxcom Electronics Co.,Ltd.		
X:XXX	DR: GRANT	Title: 10/100Base-T Single Port Transformer Modules		
ANGLES $\pm 1^\circ$	UNIT: mm	PART NO.: TRC1102NL		
	SCALE: 2/1	SHEET: 2/4	REV: A	DWG NO.: TRC14032601

IR Reflow:

REV.	ECN NO.	DESCRIPTION	DATE	APPD
A	REL		2015-05-25	

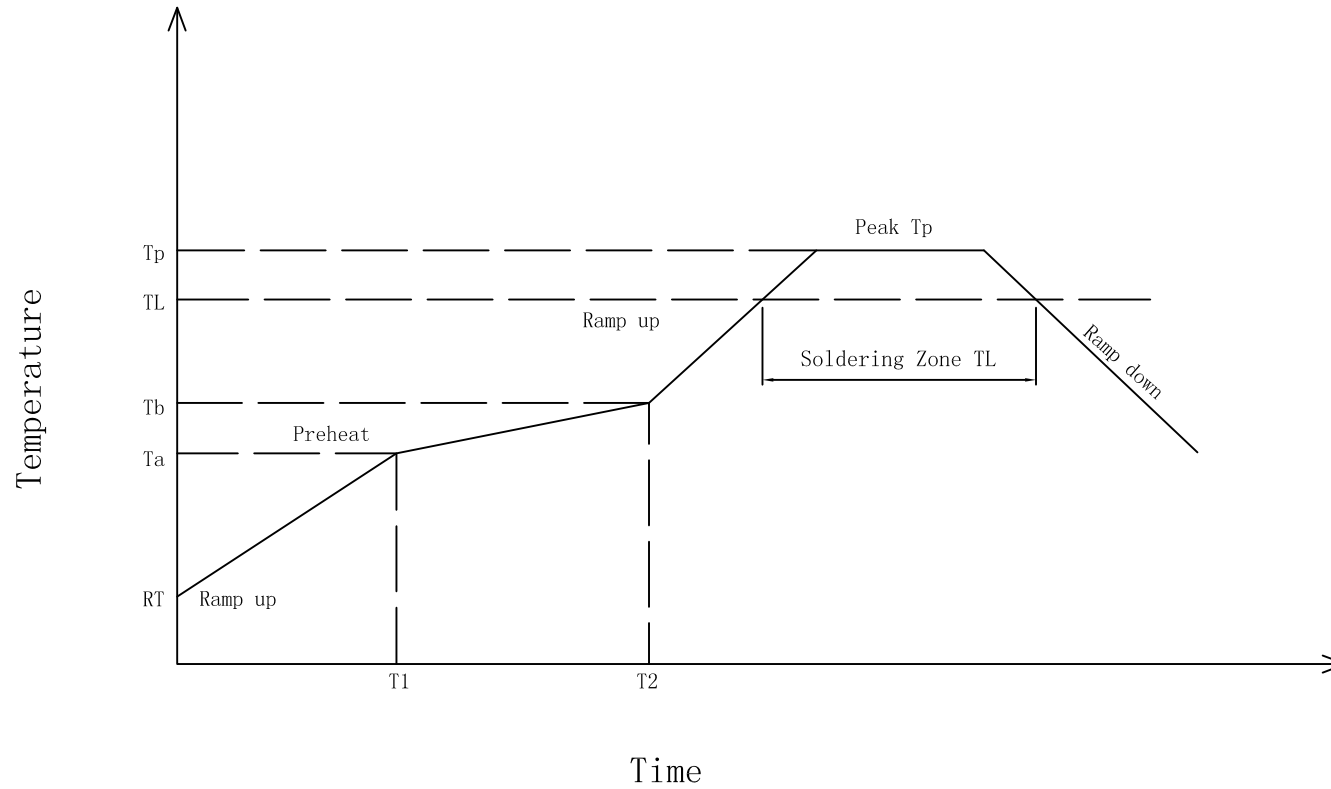

Preheat:
 Temperature (Ta-Tb) : 150-200°C
 Time (T1-T2) : 60-180s

Holding Temperature: 217°C
 Time (TL) : 60-150s

Max Temperature (Tp) : 250 (+0/-5°C)
 Max Time (Tp) : 30s

The average speed: 3°C/S Max
 The average cooling speed: 6°C/S Max

From 25°C to Products out of the furnace: 6 minutes Max



X:X	APPD:	Trxcom		
X:XX ±0.25	CHKD:	HuiZhou Trxcom Electronics Co., Ltd.		
X:XXX	DR: GRANT	Title: 10/100Base-T Single Port Transformer Modules		
ANGLES ±1°	UNIT: mm	PART NO.: TRC1102NL		
	SCALE: 2/1	SHEET: 3/4	REV: A	DWG NO.: TRC14032601

Packing:

REV.	ECN NO.	DESCRIPTION	DATE	APPD
B	REL		2015-05-25	

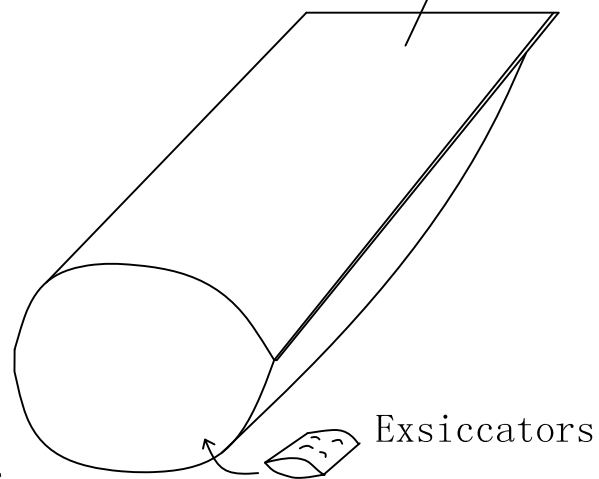
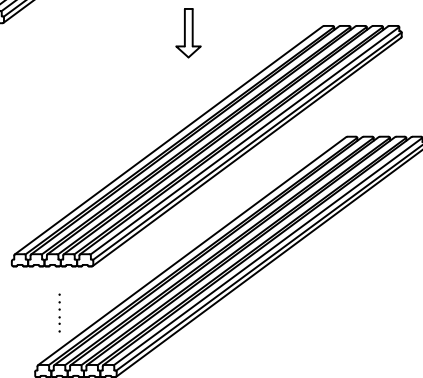
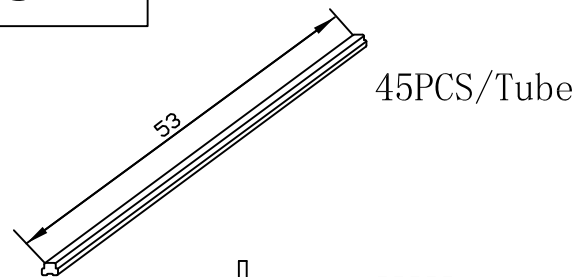

- ◆ 1 Tube = 45PCS
- ◆ 1 Inner Carton = 120Tube =5400PCS
- ◆ 1 Export Carton = 2 Inner Carton =10800PCS
- ◆ Net Weight: 6.5kg
- ◆ Gross Weight: 13kg

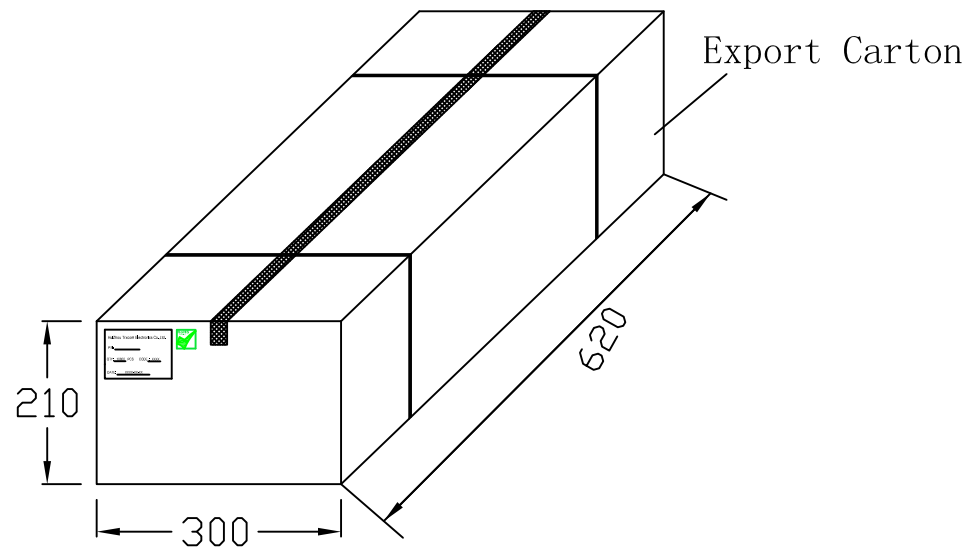
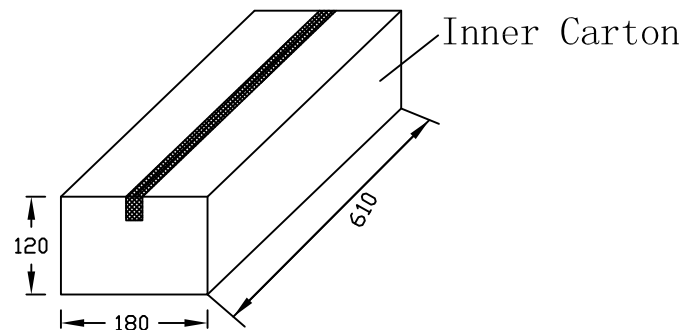

X:X	APPD:	Trxcom		
X:XX ±0.25	CHKD:	HuiZhou Trxcom Electronics Co.,Ltd.		
X:XXX	DR: GRANT	Title: 10/100Base-T Single Port Transformer Modules		
ANGLES ±1°	UNIT: mm	PART NO.: TRC1102NL		
	SCALE: 2/1	SHEET: 4/4	REV: B	DWG NO.: TRC14032601