

Mechanical :

| REV. | ECN NO. | DESCRIPTION | DATE | APPD |
|------|---------|-------------|------------|------|
| A | REL | | 2015-06-09 | |

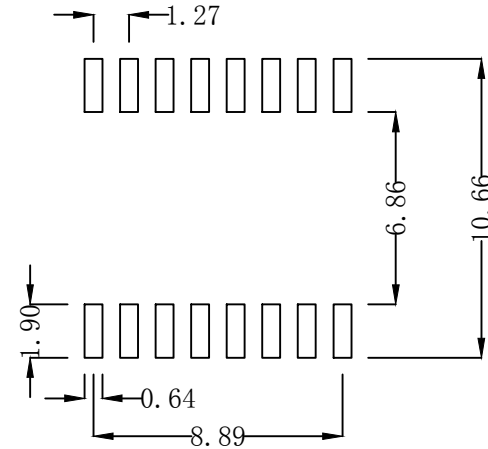

SUGGESTED PAD LAYOUT

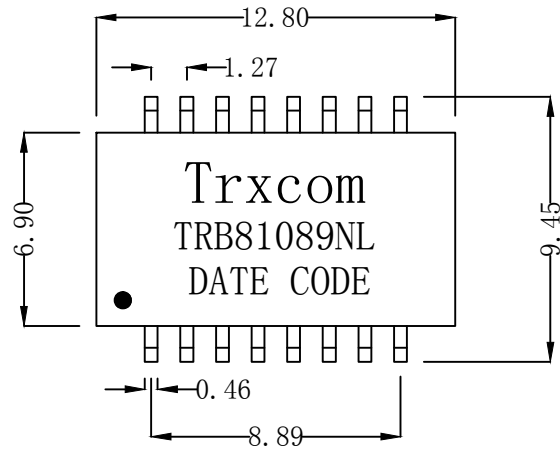
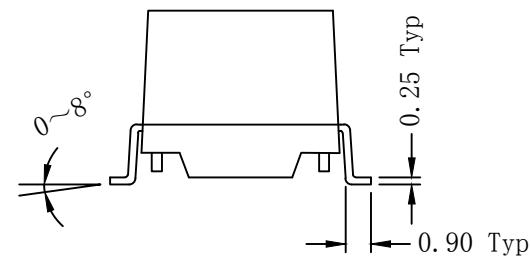
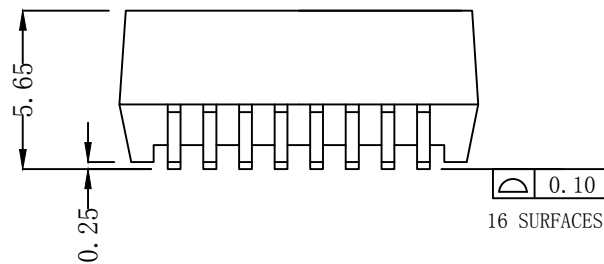

NOTES:

1. T1/CEPT/ISDN-PRI Transformer.
2. With various turns ratios.
3. The part is RoHS compliant.
4. Maximum reflow temperature is 250°C, 5 Sec.
5. UL Certification: File Number E321120.

| | | |
|------------|------------|---|
| X:X | APPD: | Trxcom Huizhou Trxcom Electronics Co., Ltd. |
| X:XX ±0.25 | CHKD: | |
| X:XXX | DR: SEA | TITLE: T1/CEPT/ISDN-PRI Transformers |
| ANGLES ±1° | UNIT: mm | PART NO.: TRB81089NL |
| | SCALE: 4/1 | SHEET: 1/4 |
| | REV: A | DWG NO.: TRC10083130 |

Schematic:

| REV. | ECN NO. | DESCRIPTION | DATE | APPD |
|------|---------|-------------|------------|------|
| A | REL | | 2015-06-09 | |

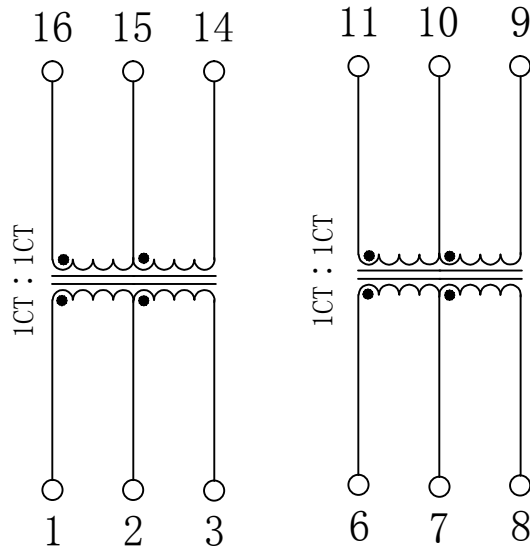

Electrical Specifications @25°C

- Turns Ratio: (Pri : Sec $\pm 5\%$)
1CT : 1CT & 1CT : 1CT
- Primary Pins: 1-3, 6-8
- OCL: 1.2mH Min & 1.2mH Min
- Cw/w: 30pF Max & 30pF Max
- LL: 0.8uH Max & 0.8uH Max
- DCR: 0.7 Ω Max & 0.7 Ω Max
- Isolation Voltage: 1500 Vrms
- Operating Temperature: -40°C ~ +85°C.



| | | |
|----------------------|------------|---|
| X:X | APPD: | Trxcom Huizhou Trxcom Electronics Co., Ltd. |
| X:XX ± 0.25 | CHKD: | |
| X:XXX | DR: SEA | TITLE: T1/CEPT/ISDN-PRI Transformers |
| ANGLES $\pm 1^\circ$ | UNIT: mm | PART NO.: TRB81089NL |
| | SCALE: 4/1 | SHEET: 2/4 |
| | REV: A | DWG NO.: TRC10083130 |

IR Reflow:

| REV. | ECN NO. | DESCRIPTION | DATE | APPD |
|------|---------|-------------|------------|------|
| A | REL | | 2015-06-09 | |

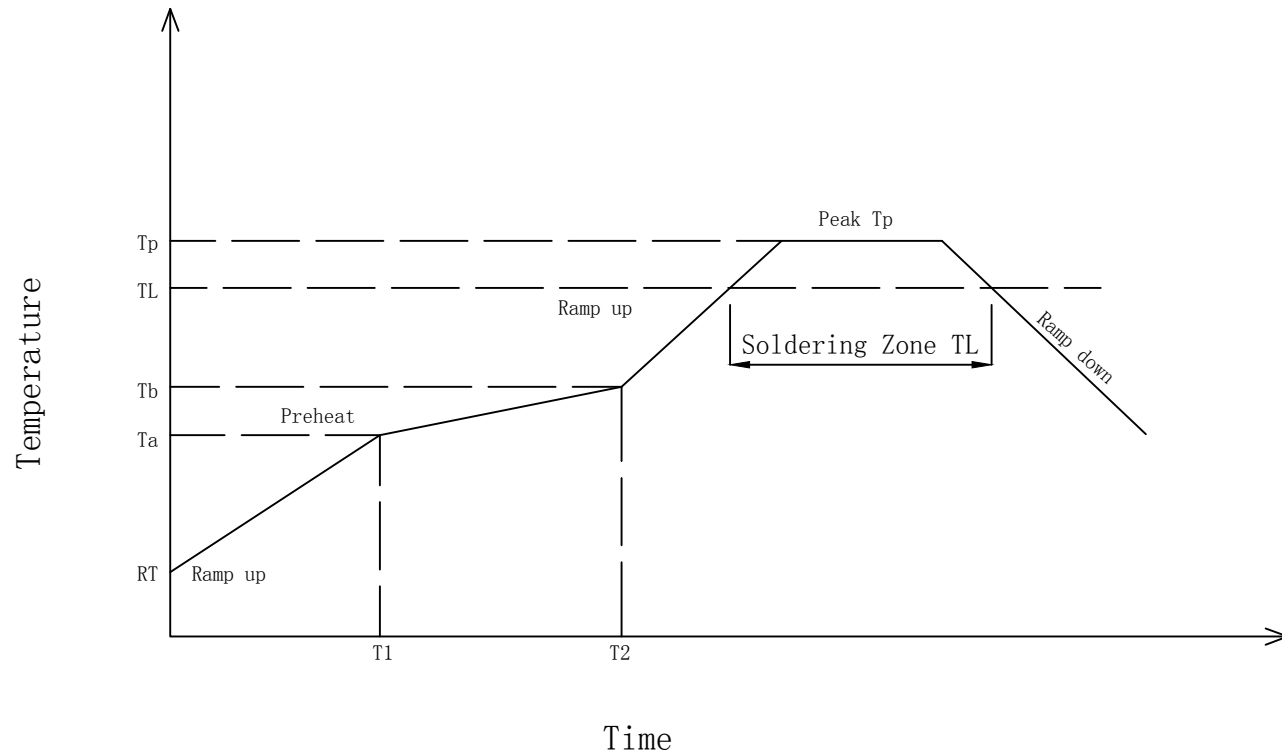

Preheat:
 Temperature (Ta-Tb) : 150-200°C
 Time (T1-T2) : 60-180s

Holding Temperature: 217°C
 Time (TL) : 60-150s

Max Temperature (Tp) : 250 (+0/-5°C)
 Max Time (Tp) : 30s

The average speed: 3°C/S Max
 The average cooling speed: 6°C/S Max

From 25°C to Products out of the furnace: 6 minutes Max



| | | |
|------------|------------|---|
| X:X | APPD: | Trxcom Huizhou Trxcom Electronics Co., Ltd. |
| X:XX ±0.25 | CHKD: | |
| X:XXX | DR: SEA | TITLE: T1/CEPT/ISDN-PRI Transformers |
| ANGLES ±1° | UNIT: mm | PART NO.: TRB81089NL |
| | SCALE: 4/1 | SHEET: 3/4 |
| | REV: A | DWG NO.: TRC10083130 |

Packing:

| REV. | ECN NO. | DESCRIPTION | DATE | APPD |
|------|---------|-------------|------------|------|
| A | REL | | 2015-06-09 | |

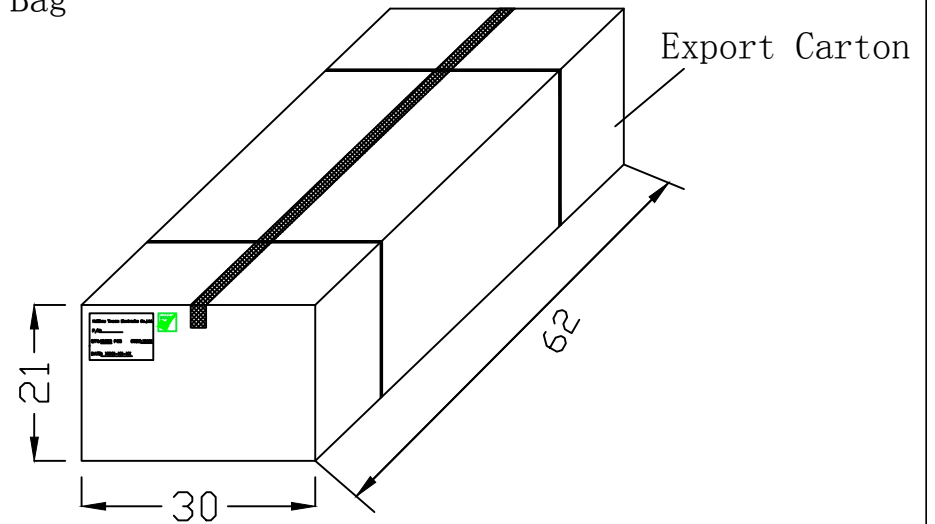
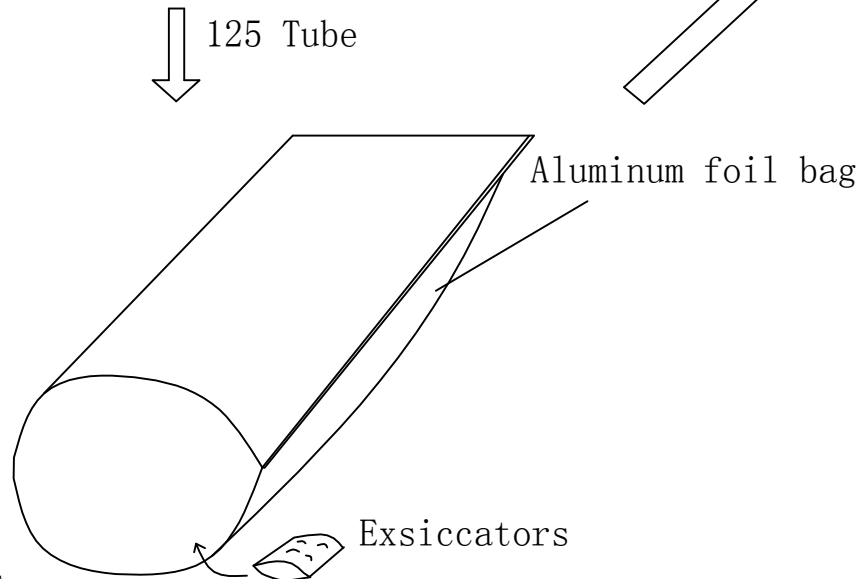
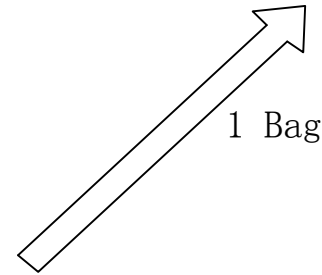
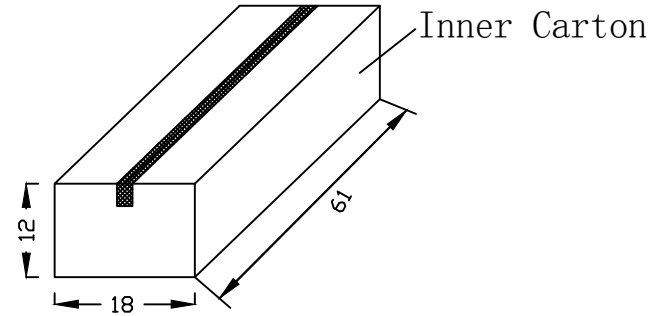
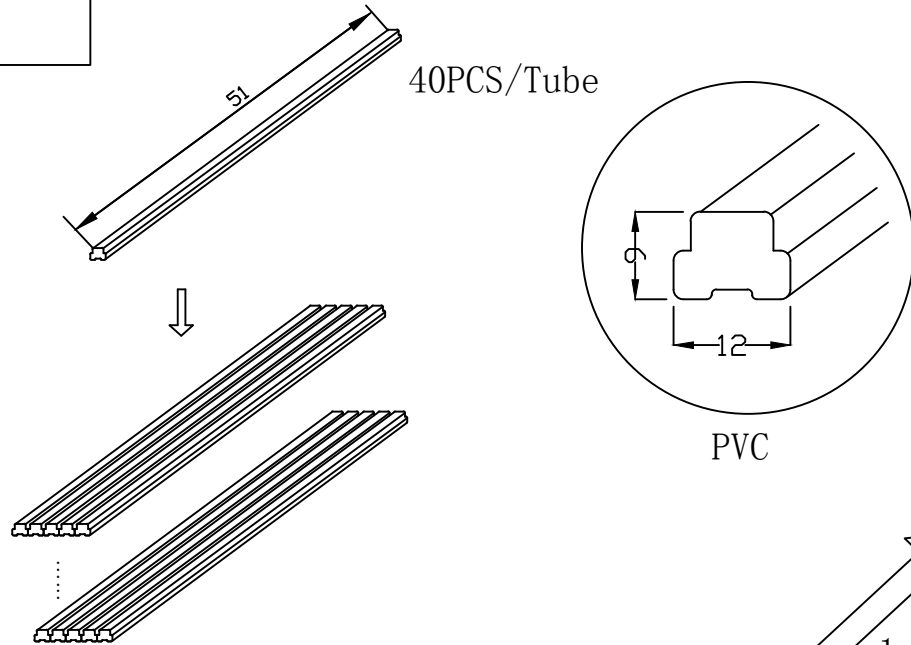

- ◆ 1 Tube = 40PCS
- ◆ 1 Inner Carton = 125Tube =5000PCS
- ◆ 1 Export Carton = 2 Inner Carton =10000PCS
- ◆ Net Weight: 6.5kg
- ◆ Gross Weight: 13kg

| | | |
|------------|------------|--|
| X:X | APPD: | Trxcom Huizhou Trxcom Electronics Co.,Ltd. |
| X:XX ±0.25 | CHKD: | |
| X:XXX | DR: SEA | TITLE: T1/CEPT/ISDN-PRI Transformers |
| ANGLES ±1° | UNIT: mm | PART NO.: TRB81089NL |
| | SCALE: 4/1 | SHEET: 4/4 |
| | REV: A | DWG NO.: TRC10083130 |