

NO	DESCRIPTION	MATERIAL	Q'TY	FINISH
1	SHELL	BRASS	1	NICKEL
2	BODY 1	BRASS	1	NICKEL
3	GASKET	SI RUBBER	1	RUBBER
4	WASHER	BRASS	1	NICKEL
5	SPRING	SK-5	1	NICKEL
6	WASHER	BRASS	1	NICKEL
7	INSULATION	DELRIN	1	DELRIN
8	PIN	BRASS	1	GOLD
9	BODY 2	BRASS	1	NICKEL
10	WASHER	BRASS	1	NICKEL
11	RING	BRASS	1	NICKEL

D

C

B

A

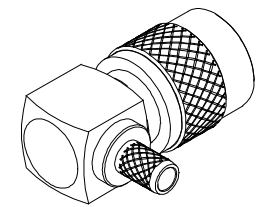
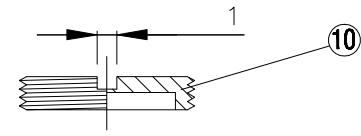
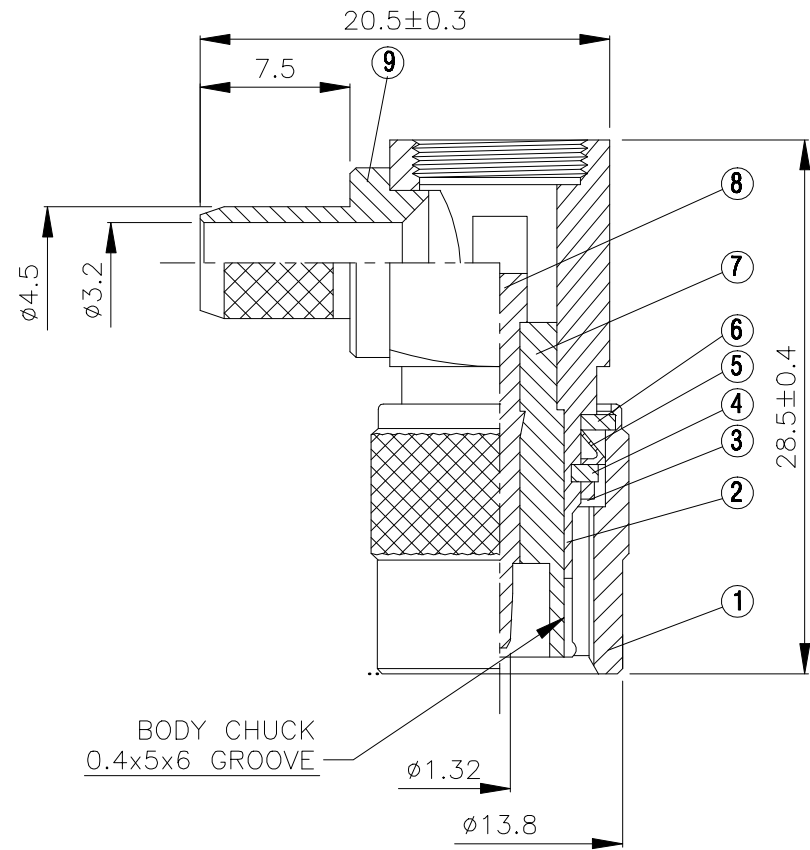
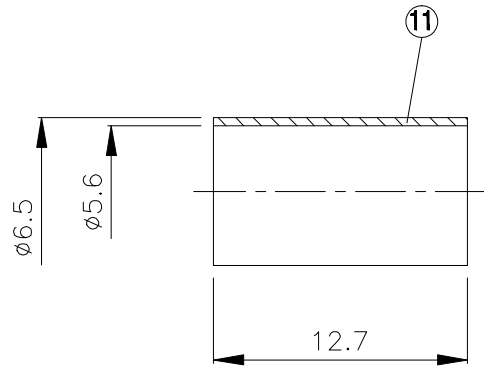

D

C

B

A

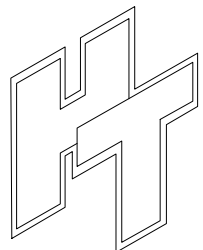

**HUS-TSAN GROUP CO., LTD.**

P.O. BOX 40-76. TAINAN. TAIWAN, R.O.C.

TITLE **TNC MALE ANGLE CRIMP FOR RG 58/U(7404)**

PART NO. **TNC-04F-DGN**

DRAWING NO. **TNC 04F DGN**

DRAWN **MARY** DATE **89.11.05**

CHECKED **蘇志欣** DATE

Q.A. **蘇姿潔** DATE

APPROVAL **徐燦霖** DATE

REVISION DATE

**DIMENSIONS ARE IN MILLIMETERS**

**UNLESS OTHERWISE SPECIFIED TOLERANCE**

**0.5-5=±0.2 120-315=±1**

**5-30=±0.4 315-1000=±1.6**

**30-120=±0.6 1000-2000=±2.4**

SCALE **4:1** SIZE **A**

**REVISION**

DESCRIPTION ENGINEER

4

3

2

1