

sProduct Datasheet



The global certified TLD-400-C is an extremely high efficiency **smart LED driver for tunable spectrum grow lights** with multiple output channels. 100khour long life and 7-year warranty provide high confidence to luminaire users. All around protections including digital OTP with auto-recovery secure non-stop operation for luminaires.



- Features 2
- Model List 2
- Technical Data 3
- Safety/EMC Compliance 4
- Dimming 4
- Programming 5
- Lifetime vs. Case Temperature 6
- Power Factor vs. Load 6
- THD vs. Load 7
- Efficiency vs. Load 7
- Inrush Current 8
- Dielectric Strength 9
- Tc Point 9
- Packaging Information 9
- Mechanical Design 10
- Output Operation Range 12
- Revision History 12

■ Features

- Absolute Supply Voltage: 180-528Vac
- **4 Independent Channel Outputs Max.**
- Ground Wire at Output
- 94% Efficiency Max.
- Low Inrush Current
- 100,000Hour Life @ Tc=75°C
- 7 Year Warranty @ Tc<=75°C
- Multiple Channel Programmability
- Knob Dimming
- RJ25 Daisy Chain Connection
- Dim Off with 0.5W Standby Power
- 12V 300mA Auxiliary Power to Power Controllers and Fans
- UL Class P
- Global Certified Model Available
- Safety according to UL8750, EN 61347-1, 61347-2-13, 62384

■ Model List

Model Number	Input Voltage Range	Output Channel	Max Output Power	Output Voltage	Full Power Settable Current Min	Full Power Settable Current Max	Protocol
TLD-400-C990-ENZ #abcdTS	180-528Vac	1	P1: 400W	30 - 53Vdc	7.5A	9.9A	0-10V
		2	P2: 100W	22 - (V _{CH1} -8V)	2.1A	3A	
		3	P3: 100W	22 - (V _{CH1} -8V)	2.1A	3A	
		4	P4: 100W	22 - (V _{CH1} -8V)	2.1A	3A	

- Note: 1. P=P1+P2+P3+P4, P is <=400W
 2. See the Output Operation Range Section for programmable model details
 3. Suffix #abcd definition is shown in the Mechanical Design section
 4. TS=T2, 2 channel version, TS=T3, 3 channel version, TS=T4, 4 channel version

Z=	U	V	S	Check with Sales	W	D
Input Cable	3 pin UL cable with ground	3 pin UL cable with ground	3 pin VDE cable with ground	3 pin Global cable with ground	3 pin VDE cable with ground	2 pin VDE cable without ground
Output Cable	UL cable without ground	UL cable with ground	VDE cable without ground	Global cable with ground	VDE cable with ground	VDE cable without ground
Certified with	UL Listed Class P FCC 200-480Vac	UL Listed Class P FCC 200-480Vac	Class I 200-480Vac	UL Recognized Class I 200-480Vac	Class I 200-480Vac	Class II 200-480Vac

■ Technical Data

Input Voltage	180-528Vac
Input Frequency	47~63Hz
Power Factor	>0.95@60-100%load, refer to PF vs. Load curve
THD	<15%@60-100%load, refer to THD vs. Load curve
Input Current	1.7Amax@277Vac & Full-Load, 1.0Amax@480Vac & Full-Load
Inrush Current	See Inrush Current Section in the datasheet
Leakage Current	0.75MIU max @480Vac 60Hz, UL8750 0.7mA max @400Vac 50/60Hz, IEC60598-1
Input Under Voltage	Shut down and auto-restart
Surge Protection	Line to line 6kV, line to ground 10kV, IEC 61000-4-5
Current Accuracy	±2%Io for programmable model, ±5%Io for non-programmable model
Ripple Current	Ip-p:5%Io max
Setup Time	1.2s max
Overshoot	10% Io max & LED Load
Output Over Voltage	120% Vomax, typ.
Short Circuit	Auto recovery. The output recovers when short is removed.
Over Temperature	Lower the output current when $T_c \geq 105 \pm 10^\circ\text{C}$; Auto Recovery When $T_c \leq 70 \pm 10^\circ\text{C}$
Auxiliary Power (Vaux)	12V+/-5%, 300mA max
Operating Temperature	Case Temperature $T_c = -40^\circ\text{C} \sim +90^\circ\text{C}$; 10%RH~100%RH
Storage Temperature	$-40^\circ\text{C} \sim +85^\circ\text{C}$; 5%RH~100%RH
MTBF	$\geq 280,000$ hours, 75°C case temperature (MIL-HDBK-217F)
Lifetime	$\geq 100,000$ hours, 75°C case temperature, refer to life vs. T_c curve
Case Temperature	90°C max, marked in the T_c point of label
Dimension	309x 90 x 41.5 by mm (body), 336 x 90 x 41.5 by mm (endcaps included)
Net Weight	2100g
Packing	See Package Information Section in the datasheet

Notes: Unless specified, all the test results are measured in 25°C room temperature.

Safety/EMC Compliance

Safety Standards	Description
UL8750	Light emitting diode(LED) equipment for use in lighting products
UL1012/1310	Power units other than class 2 / Class 2 power units
IEC 61347-1	Lamp control gear Part 1: general and safety requirements
IEC 61347-2-13	Lamp control gear Part 2-13: particular requirement for d.c. or a.c. supplied electronic control gear for LED modules
IEC 62384	DC or AC supplied electronic control gear for LED modules - Performance requirements
IEC 55015/FCC Part 15	Conducted emission test & radiated emission test; ANSI C63.4:2009 Class B
IEC 61000-3-2	Harmonic current emissions; Class C
IEC 61000-3-3	Voltage fluctuations & flicker
IEC 61000-4-2	Electrostatic discharge (ESD): 8 kV air discharge, 4 kV contact discharge
IEC 61000-4-3	Radio frequency electromagnetic field susceptibility test (RS)
IEC 61000-4-4	Electrical fast transient (EFT)
IEC 61000-4-5	Surge immunity test
IEC 61000-4-6	Conducted radio frequency disturbances test (CS)
IEC 61000-4-8	Power frequency magnetic field test
IEC 61000-4-11	Voltage dips
IEC 61547	Electromagnetic immunity requirements applies to lighting equipment

Dimming

Parameter	Min.	Typ.	Max.
Vdim Sourcing Current	100uA	150uA	200uA
Vdim Allowed Input Voltage	-20 V		20 V
0-10V Dimming Range	10% (Vdim=1V)	Linear	100% (Vdim=9~10V)
PWM Dimming Range	10% (Duty=10%)	Linear	100% (Duty=90-100%)
Dim off threshold	0.4V or 4%	0.5V or 5%	0.6V or 6%
Dim on threshold	0.6V or 6%	0.7V or 7%	0.8V or 8%

- Dimming Curve

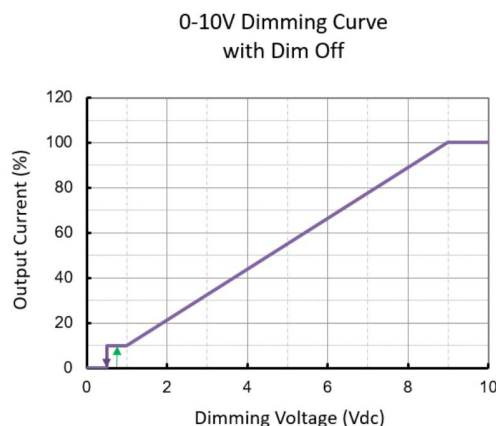

Note: CH1 can not reach the target output current if CH2, CH3 or CH4 is on and P1 +P2+P3+P4>500W.

■ Programming

- Programmable Functions

uPowerTek LED drivers offer a range of configurable functions to meet specific lighting requirements. The Output Current and Power Transfer can be set as basic programming functions. Also the software helps the users to verify right LED target operation parameters in the black line frame area.

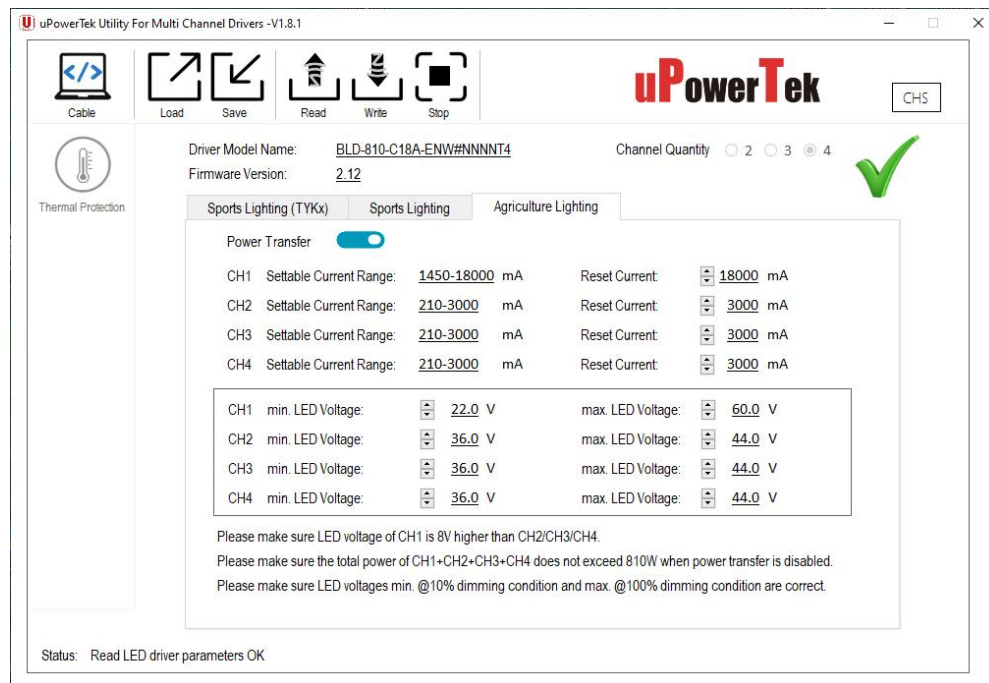

uPowreTek Programming Software Interface

- Connection Guide

This guide provides simple connection diagrams to help users understand the programming system. For more detailed operating instructions, including step-by-step procedures and additional configurations, please visit our website. You can download the comprehensive user manual and necessary software from the following link:

<https://www.upowertek.com/download-2/>.

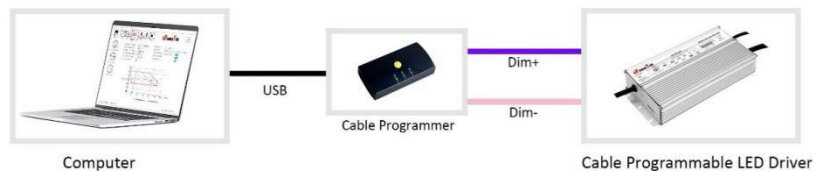

■ Lifetime vs. Case Temperature

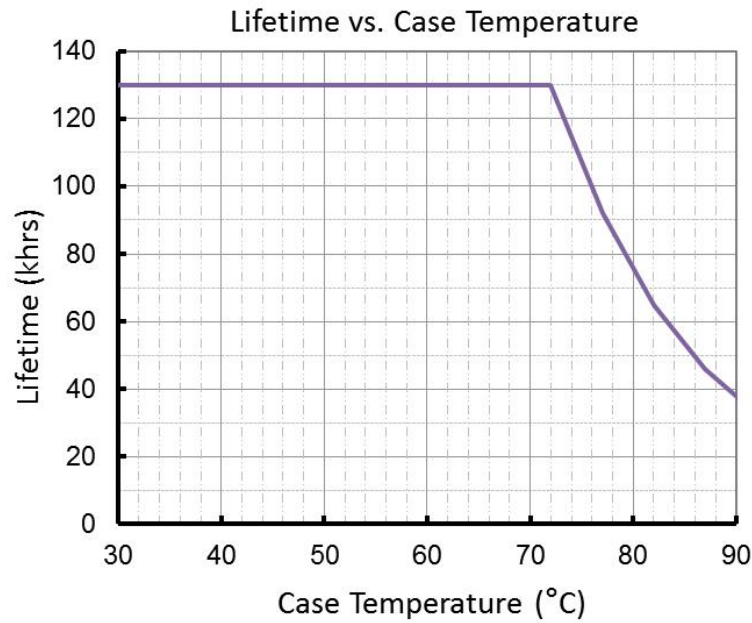

(End of Life: Maximum Failure Rate=10%)

■ Power Factor vs. Load

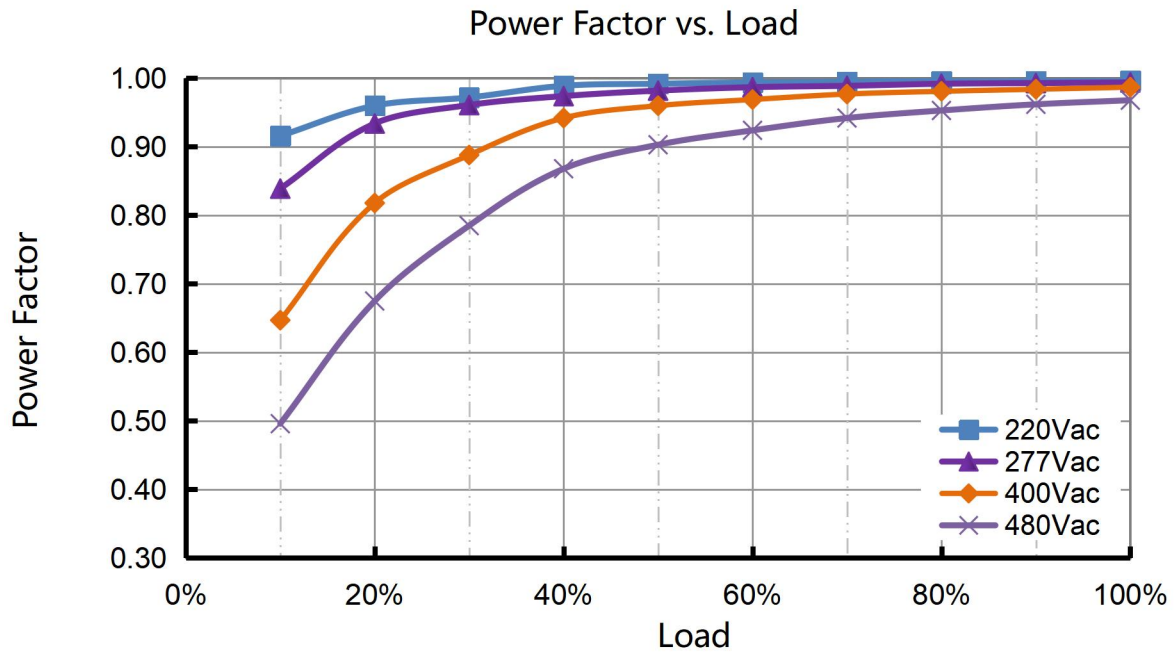

■ THD vs. Load

THD vs. Load

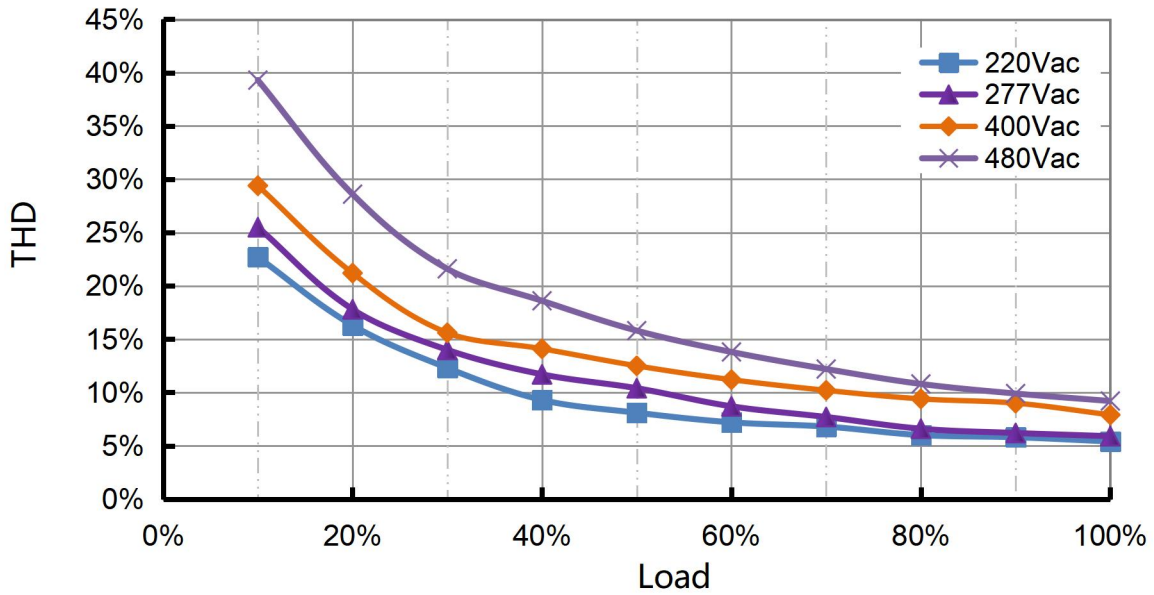

■ Efficiency vs. Load

Efficiency vs. Load (C990)

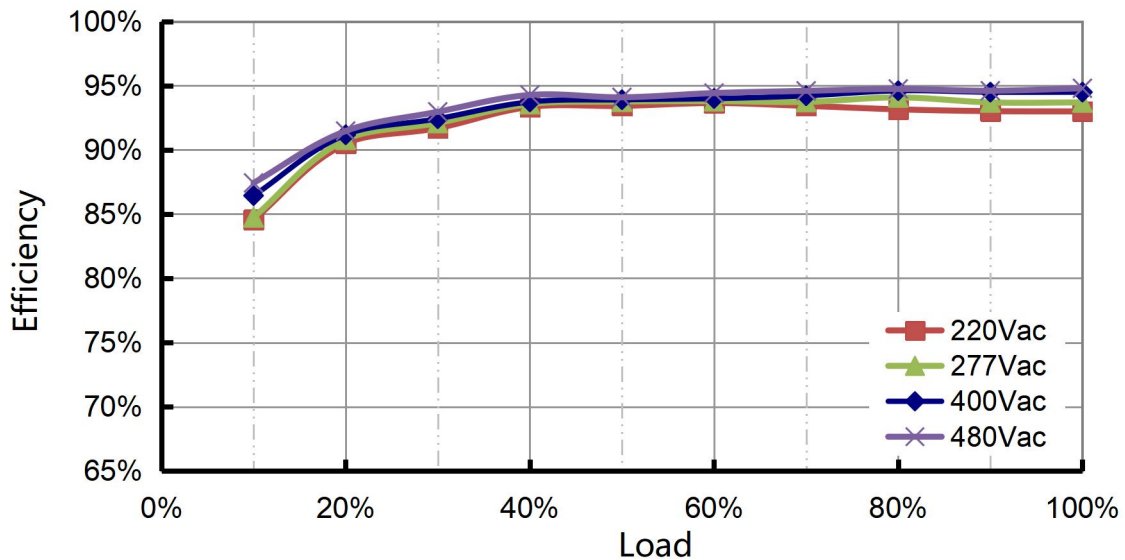

Inrush Current

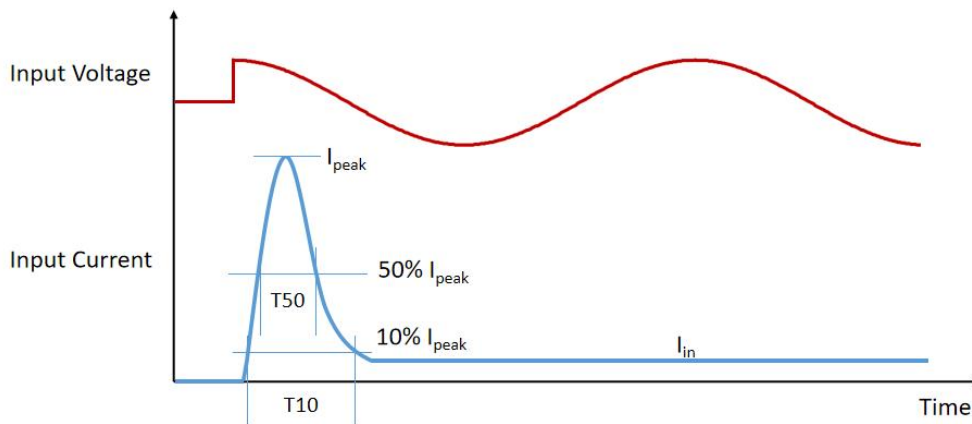

Input Voltage	I_{peak}	10% -10% T10 Duration	50% -50% T50 Duration
220Vac	64A	824 μ s	400 μ s
277Vac	87.6A	804 μ s	390 μ s
400Vac	101.2A	680 μ s	320 μ s
480Vac	121.2A	660 μ s	300 μ s

- MCB Suggestion

Type	B10	B16	B25	B32	C10	C16	C25	C32	D10	D16	D25	D32
220Vac	2	3	6	7	2	4	7	9	3	5	8	10
277Vac	2	3	5	7	3	5	9	11	4	6	10	13
400Vac	2(x3)	3(x3)	6(x3)	7(x3)	2(x3)	4(x3)	7(x3)	9(x3)	3(x3)	5(x3)	8(x3)	10(x3)
480Vac	2(x3)	3(x3)	5(x3)	7(x3)	3(x3)	5(x3)	9(x3)	11(x3)	4(x3)	6(x3)	10(x3)	13(x3)

Three phase wiring suggestion.

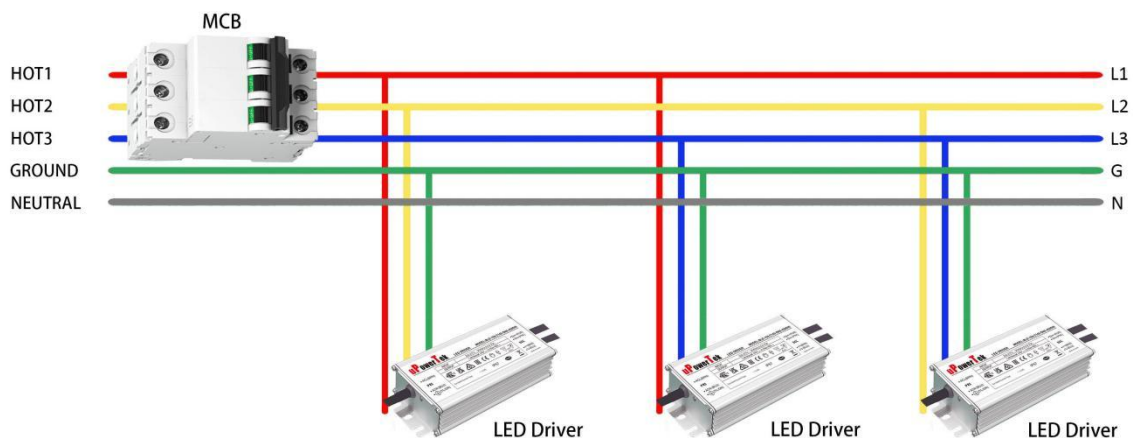

■ Dielectric Strength

Unit: Vac	Input	Output	Dimming	Case
Input	-	3920	3920	1960
Output	3920	-	1960	1960
Dimming	3920	1960	-	1960
Case	1960	1960	1960	-

■ Tc Point

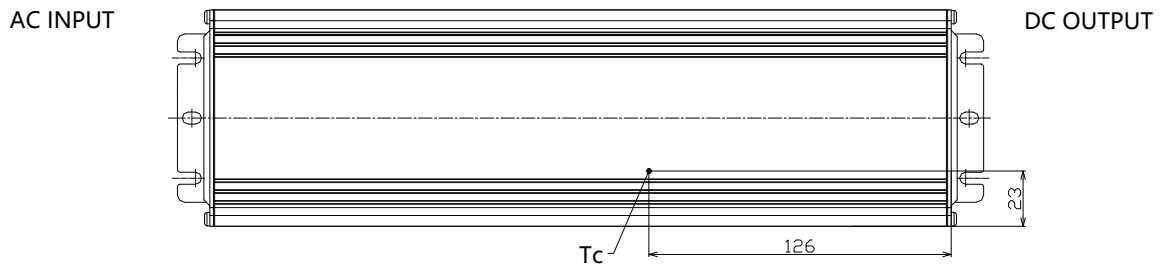

■ Packaging Information

Typical Carton Dimension(L×W×H)	490×370×125 mm
Positioning plate	2pcs/carton
Shield Board	1pcs/carton
LED Drivers/LED	6pcs/carton
Net Weight	9.6 kg/carton
Gross Weight	10.5 kg/carton

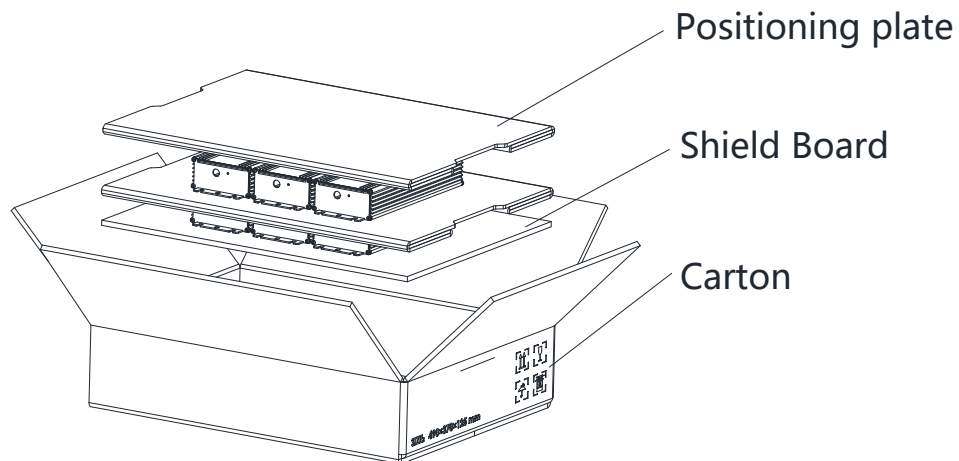

Mechanical Design

- UL Cable

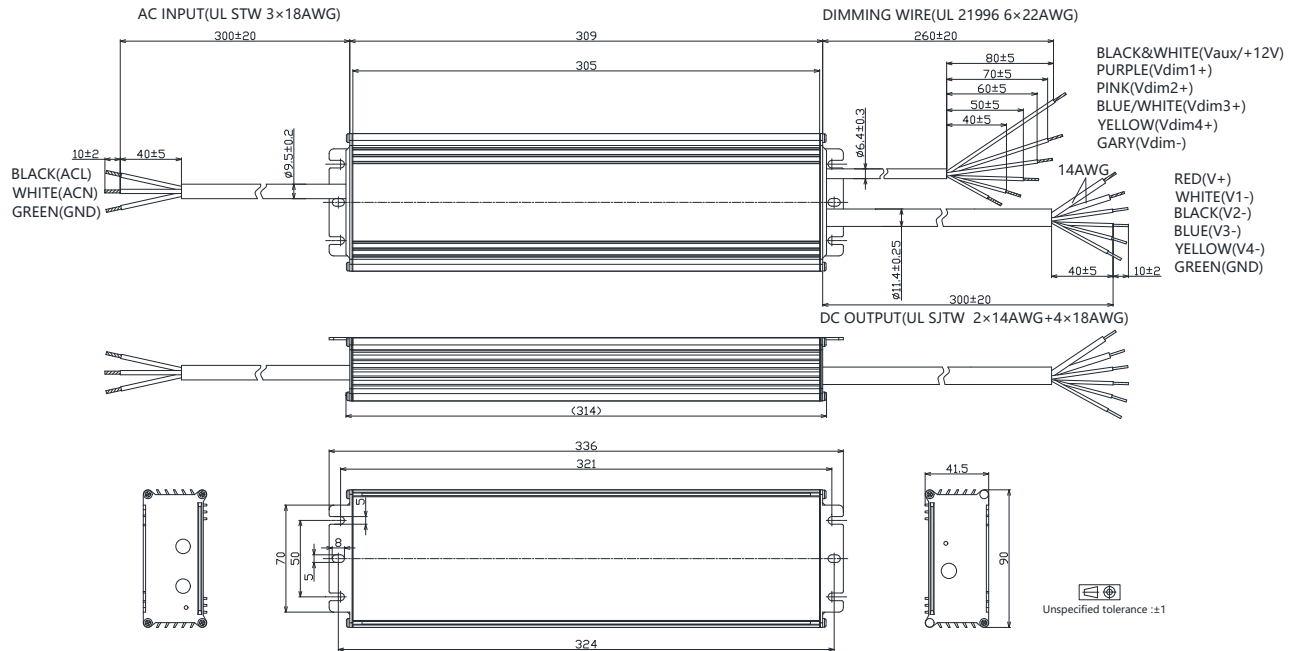

- VDE Cable

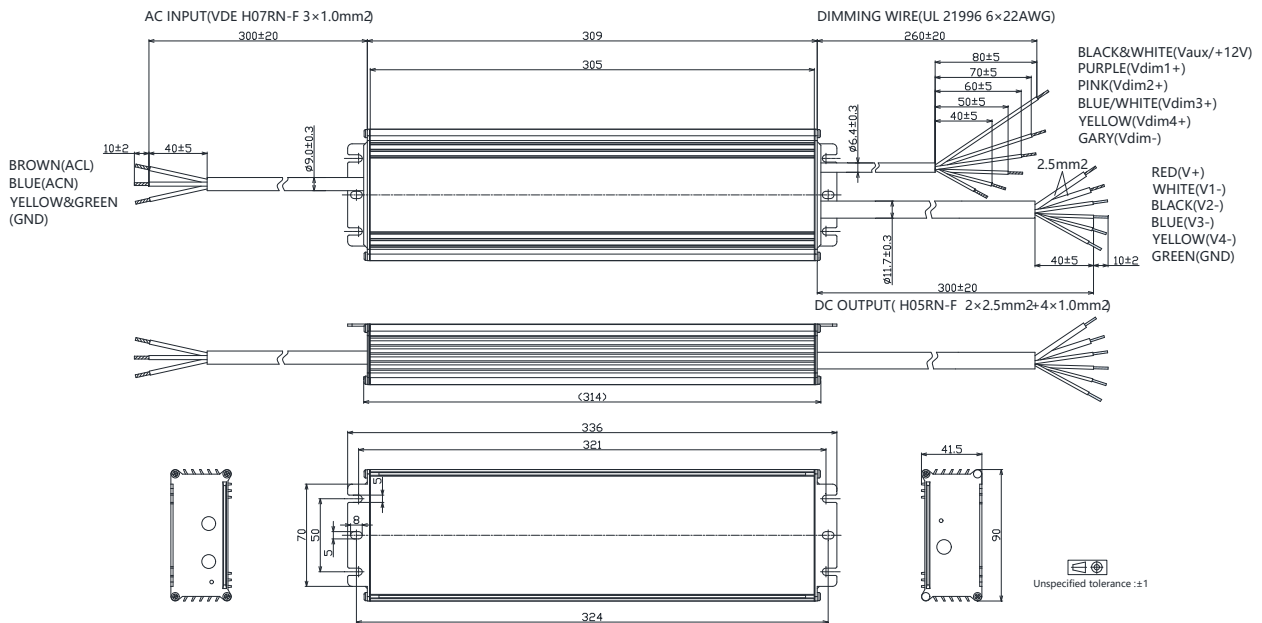

400W, 200-480Vac Input, Quad Output LED Driver

- Customized Endcap Version (Example below, check with uPowerTek sales team about correct data according to different configuration)

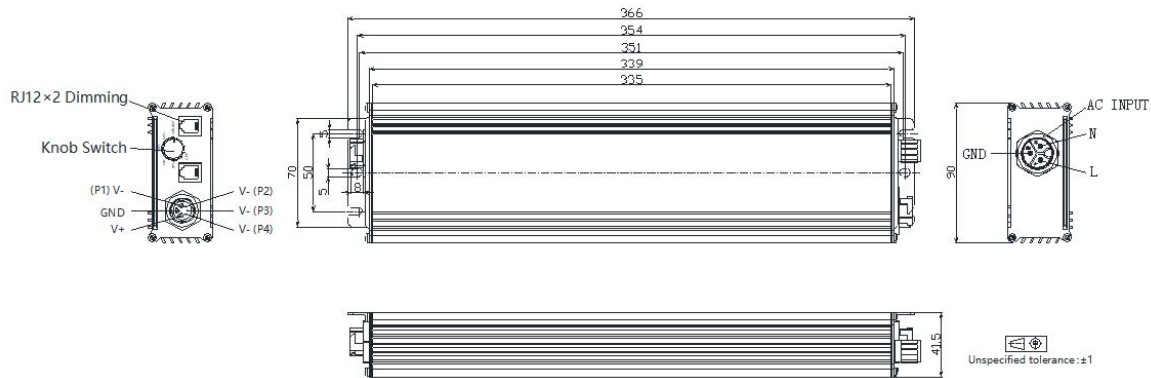

- Add suffix #abcdTS to the end of part number to indicate different configuration.

Item	Value Definition	Description
Input	a	F: M19 waterproof connector P: C14 plug N: Same cable as standard version
Output	b	F: M19 waterproof connector, 2 pin N: Same cable as standard version
Dimming	c	F: M12 waterproof connector R: RJxx (xx=25,14,12,11) connector x 2 N: Same cable as standard version
Knob	d	K: Knob with steps B: Knob without steps N: No knob

- RJ25 Pin Description (can be customized according to control system)

Pin	Description	Pin	Description
1	CH1 0-10V	4	CH4 0-10V
2	CH2 0-10V	5	12V Aux-power
3	CH3 0-10V	6	Dim-/RTN

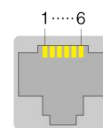

- Knob Description

Position	Description
100%/EXT	If there is no external control, 100% output. If there is external control, output is controlled by external signal.
Off,20%,40%,60%,80%	External signal invalid. Using knob control will turn off CH2, 3 and 4, with only CH1 left.

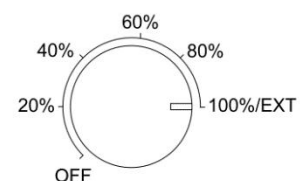

■ Output Operation Range

Model	Typical Set Output Current (mA)	Max Output Power (W)	Output Voltage Min (V)	Output Voltage Max(V)	Minimum Dimming Current (mA)
-C990	9900	400	30	40	990
	9600	400	30	42	960
	9300	400	30	43	930
	9000	400	30	44	900
	8700	400	30	46	870
	8400	400	30	48	840
	8100	400	30	49	810
	7800	400	31	51	780
	7500	400	32	53	750
	7200	382	32	53	750
	6900	366	32	53	750
	6600	350	32	53	750
	6300	334	32	53	750

	750	40	32	53	750

■ Revision History

Revision	Date	Contents
A	2023-04-07	New Release
B	2023-07-14	1. Update cable selection table in Model List Section 2. Output range updated
C	2024-07-25	1. Power factor, THD, efficiency curves updated by 10-100% load range 2. MCB usage and driver quantity section added 3. Inrush current data updated