

**SPECIFICATION**

Voltage Rating:150V AC  
 Current Rating:10Amp/Way Max.  
 Insulation Resistance:5000 Megaohms/1000V  
 Contact Resistance:20 Milliohms Max.  
 Withstanding Voltage:1500V AC For 1Minute  
 Wire Range:16~24AWG  
 Torque:2kgf.cm/M2  
 Operation Temperature:-30°C~+105°C  
 Soldering Reliability:Test Temperature=250°C±10°C/5Seconds Max.  
 Contact(Metal Housing):Brass(CuZn)  
 Surface Of Solder Tail:Tin Plated  
 Terminal Screw:Steel,Galvanized And Chromatized  
 Insulator Body(Housing):Glass-Filled Thermoplastic  
 (UL94V-0),Green

RoHS Compliant

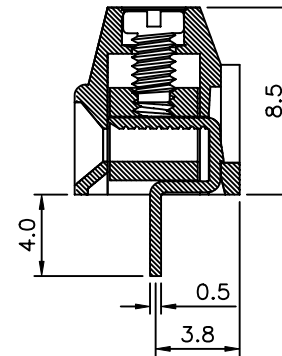
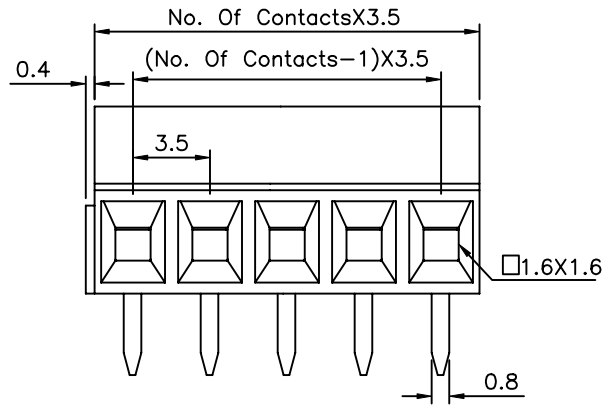
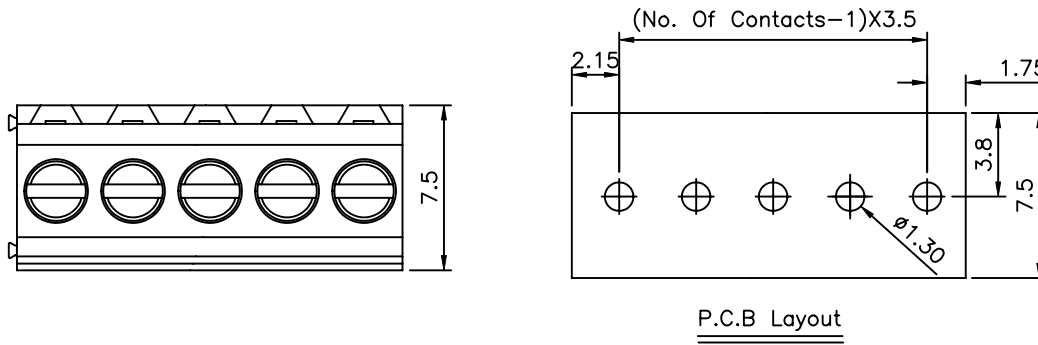

**AUK** A MEMBER OF AUK GROUP  
**太聯事業股份有限公司**  
**AUK CONTRACTORS CO., LTD.**

|                       |      |             |    |  |  |  |                   |                |
|-----------------------|------|-------------|----|--|--|--|-------------------|----------------|
| CATEGORY              |      | APPROVED BY |    | UNLESS OTHERWISE SPECIFIED TOLERANCES ARE<br>X. ±0.50<br>.X ±0.30<br>.XX ±0.20<br>X° ±1° |  |  |                   |                |
| PART No. TB35XXA-H    |      | MEI         |    |  |  |  |                   |                |
| DRAWING No. TB35XXA-H |      | HZF         |    |  |  |  |                   |                |
|                       |      | XYH         |    |  |  |  |                   |                |
| SCALE                 | NONE | REV.        | A0 | UNIT mm  |  |  | △ A0 NEW RELEASE  | HZF 04/07/2009 |
|                       |      |             |    |  |  |  | NO.REV. REVISIONS | CHK DATE       |