

100-277Vac 10kV Input Surge Protection Device

■ Features

- 10kV Surge Protection (L-N and L/N-G)
- Series Usage
- High temperature, 85°C maximum surface temp rating, flameproof plastic enclosure
- 6-leaded device that protects Line-Ground, Line-Neutral, and Neutral-Ground
- UL1447 Type 4
- In accordance with IEC 61643-1 & IEC 61643-11 & EN61000-4-5 & UL 1449 guidelines.
- Only Suitable for Outdoor LED driver series



■ Application

Street lights, Tunnel lights, Flood lights

■ Technical Data

Input	100~277Vac 50/60Hz, 6Amax
Max. Continuous operating voltage	305Vac
Nominal discharge current: in (8/20μs)	5kA
Max. Discharge current: imax (8/20μs)	10kA
Surge tolerance	10kV
Clamping voltage	≤1.2kV (L-PE,N-PE,L-N)
Response time	≤25ns
Dimensions	79x43x32mm
Connecting wire	1.5mm ² (L=red;N=black; PE=y/g)
Shell material	Flame retardant plastics, UL94-V0
Shell color	Black
Working environment	Temperature: - 40°C ~ + 85°C; Relative humidity: ≤95%
Mounting bracket	Wall type
Shell protection grade	IP67
Weight	0.10kg

■ Wiring Diagram

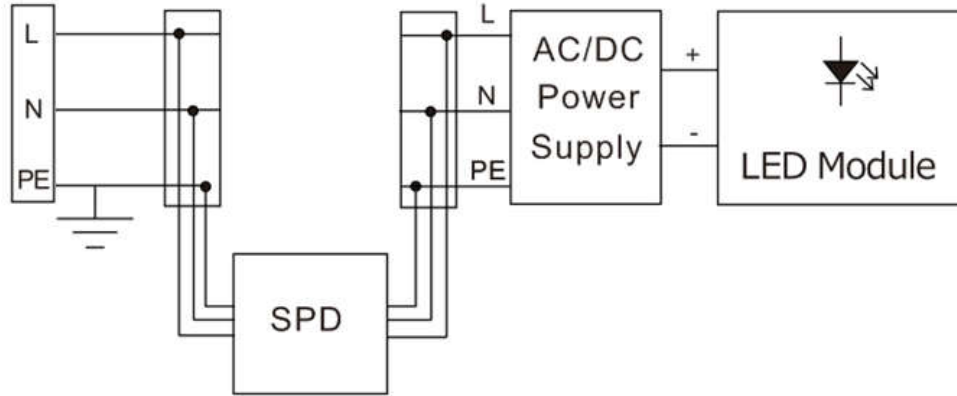

■ Installation Notice

1. The SPD should be installed/connected in series with the luminaire system.
2. Incorrect installation may significantly impair the performance of the SPD. It is particularly important that all installation procedures and guidelines be followed exactly.
3. Before starting any installation procedures, verify service voltage (AC or DC) with a volt meter to ensure that the correct model has been selected for the supply voltage. Do not install the SPD if measured voltage exceeds unit ratings.
4. Install the SPD as close to luminaire or driver as possible.
5. Remove power from electrical system prior to installation.
6. Ensure that all connections are correct before energizing.
7. Never install on an ungrounded system

■ Mechanical Design

