

NO	DESCRIPTION	MATERIAL	Q'TY	FINISH	REMARK
1	BODY 1	BRASS	1	GOLD	B-SMA0155-G
2	INSULATION 1	TEFLON	1	TEFLON	I-0053T
3	PIN	BE CU	1	GOLD	P-SMB0145-G
4	BODY 2	BRASS	1	GOLD	B-SMB0479-G
5	BODY 3	BRASS	1	GOLD	B-SMB0245-G
6	INSULATION 2	TEFLON	1	TEFLON	I-0136T
7	WASHER 1	BRASS	1	GOLD	W-0023-G
8	RING	BRASS	1	GOLD	R-0002-G

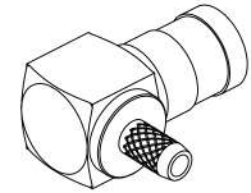

(Recommended Stripping Dimension)

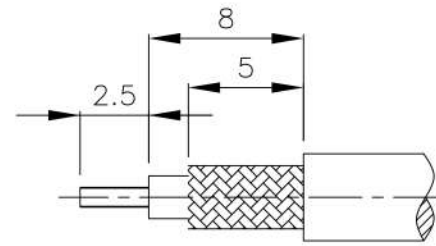
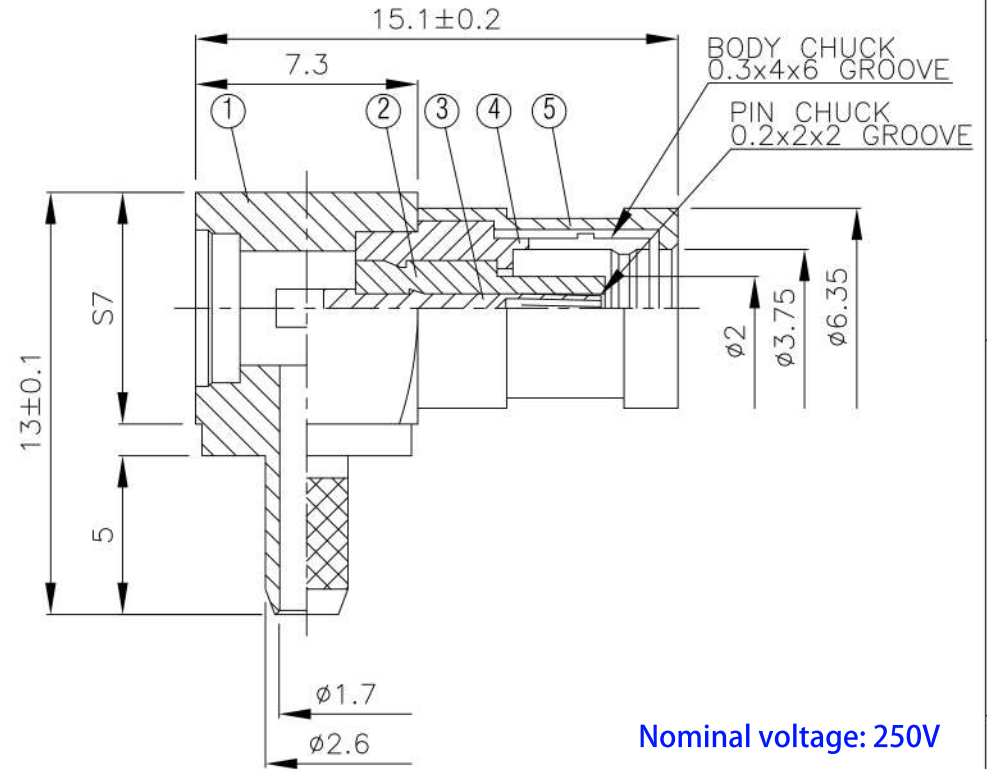
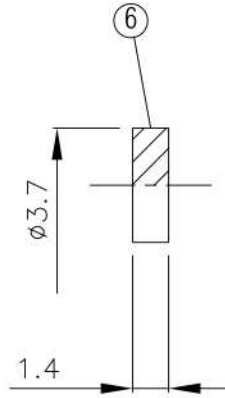
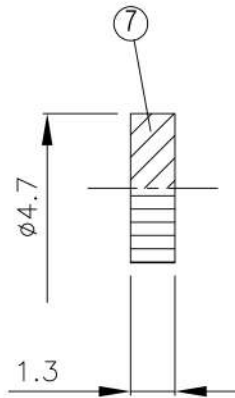
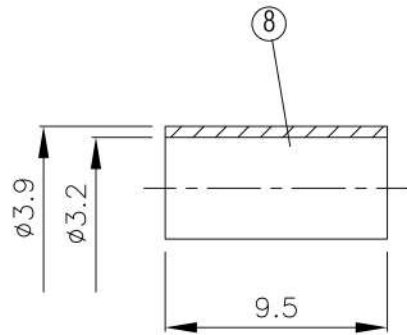

Nominal voltage: 250V

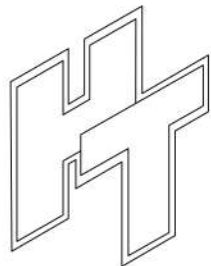

HUS-TSAN GROUP CO., LTD.

P.O. BOX 40-76. TAINAN. TAIWAN, R.O.C.

TITLE SMB FEMALE ANGLE CRIMP FOR RE316U, 174U, Series SMB-03

PART NO. SMB-03LV1-TGG

DRAWING NO. SMB-03LV1-TGG

DRAWN MARY DATE 91.03.06

CHECKED 黃巧君 DATE 91.03.06

Q.A. 蘇姿潔 DATE

APPROVAL 徐燦霖 DATE

REVISION DATE

DIMENSIONS ARE IN MILLIMETERS

UNLESS OTHERWISE SPECIFIED TOLERANCE

0.5-5 = ±0.2 120-315 = ±1

5-30 = ±0.4 315-1000 = ±1.6

30-120 ±0.6 1000-2000 = ±2.4

SCALE 4:1 SIZE A

REVISION

DESCRIPTION	ENGINEER

A

A

4

3

2

1