

4

3

2

1

NO	DESCRIPTION	MATERIAL	Q'TY	FINISH	REMARK
1	BODY	BRASS	1	GOLD	B-SMA0620-G
2	PIN	BE CU	1	GOLD	P-SMA0407-G
3	INSULATION 1	TEFLON	1	TEFLON	I-0340T
4	INSULATION 2	TEFLON	1	TEFLON	I-0318T
5	WASHER	BRASS	1	GOLD	W-0016-G
6	NUT	BRASS	1	GOLD	N-0006-G

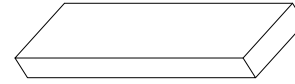

TAB CONTACT (BOARD THICKNESS 0.79)

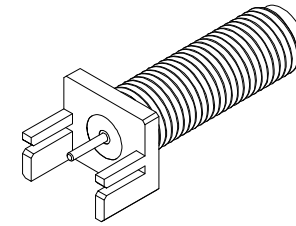

D

D

C

C

B

B

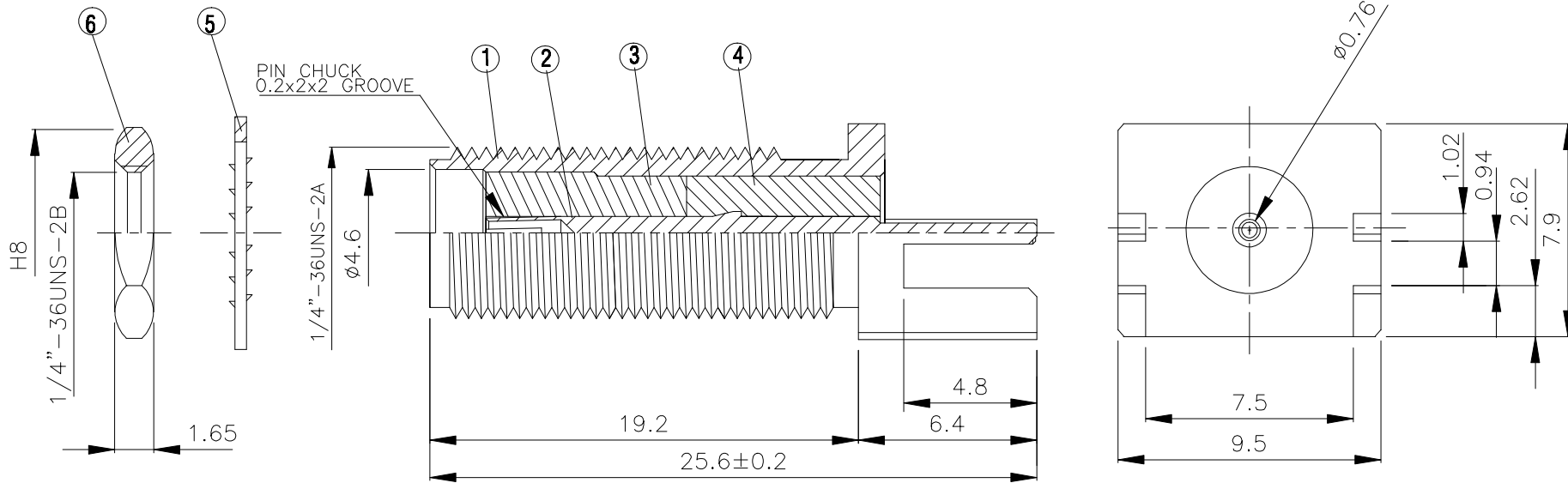

A

A

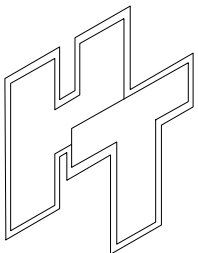

HUS-TSAN GROUP CO., LTD.
P.O.BOX 40-76.TAINAN.TAIWAN,R.O.C.

TITLE
SMA FEMALE END LAUNCH

PART NO.
SMA-10V16-TGG

DRAWING NO.
SMA 10V16 TGG

DRAWN MARY

CHECKED 蘇姿潔

Q.A. 張育誌

APPROVAL 馮健華

REVISION

DATE 96.03.15

DATE

DATE

DATE

DATE

DIMENSIONS ARE IN MILLIMETERS

UNLESS OTHERWISE SPECIFIED
TOLERANCE

0.5-5=±0.2 120-315=±1

5-30=±0.4 315-1000=±1.6

30-120=±0.6 1000-2000=±2.4

SCALE 4:1 SIZE A

REVISION

DESCRIPTION ENGINEER

4

3

2

1