

NO	DESCRIPTION	MATERIAL	Q'TY	FINISH	REMARK
1	SHELL	BRASS	1	GOLD	B-SMA0043-G
2	GASKET	SI RUBBER	1	RUBBER	RU-0008
3	INSULATION	TEFLON	1	TEFLON	I-0115T
4	WASHER	PH.BRONZE	1	GOLD	W-0012
5	BODY	BRASS	1	GOLD	B-SMA0042-G
6	PIN	BRASS	1	GOLD	P-SMA0037-G

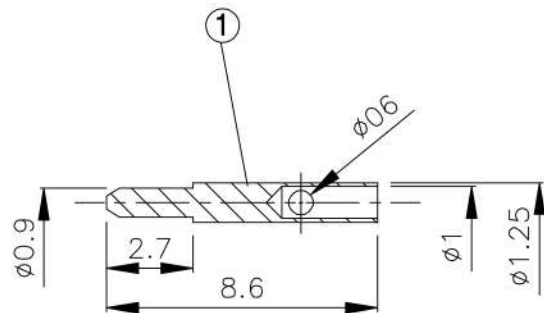
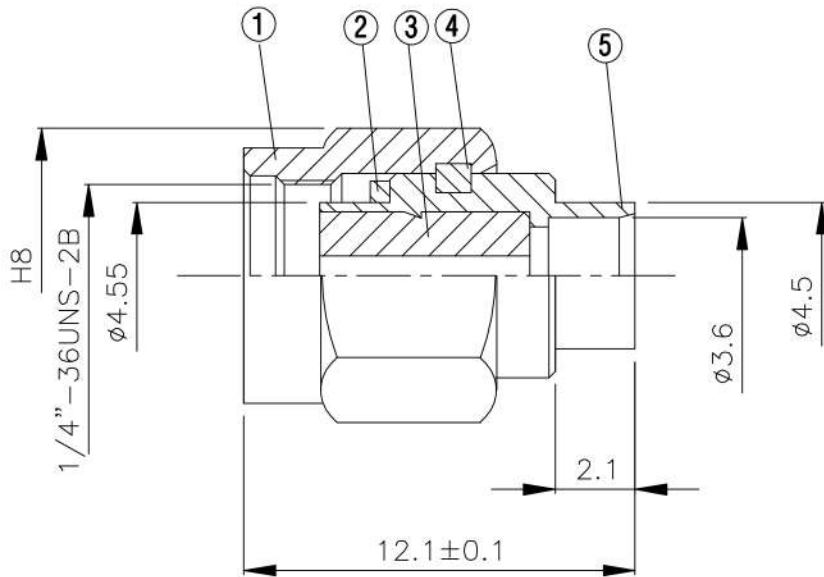
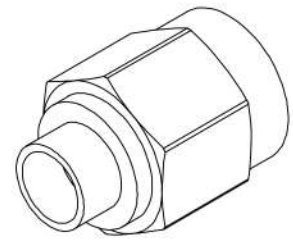
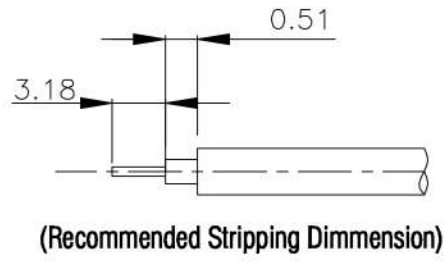

Nominal voltage: 250V

	<b>HUS-TSAN GROUP CO., LTD.</b>		DRAWN	MARY	DATE	<b>90.02.22</b>	DIMENSIONS ARE IN MILLIMETERS		REVISION	
	P.O.BOX 40-76.TAINAN.TAIWAN,R.O.C.		CHECKED		DATE	97.07.02	UNLESS OTHERWISE SPECIFIED TOLERANCE		DESCRIPTION	ENGINEER
	TITLE SMA MALE SOLDER FOR RG 402 (.141) Series SMA-03		Q.A.		DATE		0.5-5=±0.2	120-315=±1		
	PART NO. SMA-03V2-TGG		APPROVAL		DATE		5-30=±0.4	315-1000=±1.6		
	DRAWING NO. SMA 03V2 TGG		REVISION		DATE		30-120±0.6	1000-2000=±2.4		
						SCALE	4:1	SIZE	A	