

NO	DESCRIPTION	MATERIAL	Q'TY	FINISH	REMARK
1	SHELL	BRASS	1	GOLD	B-SMA0043-G
2	GASKET	SI RUBBER	1	RUBBER	RU-0008
3	INSULATION	TEFLON	1	TEFLON	I-0115T
4	WASHER	SUS	1	PASSVATED	W-0012
5	BODY	BRASS	1	GOLD	B-SMA0045-G
6	PIN	BRASS	1	GOLD	P-SMA0040-G
7	RING	BRASS	1	GOLD	R-0002-G

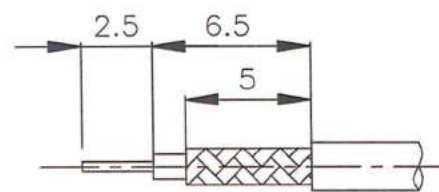

(Recommended Stripping Dimension)

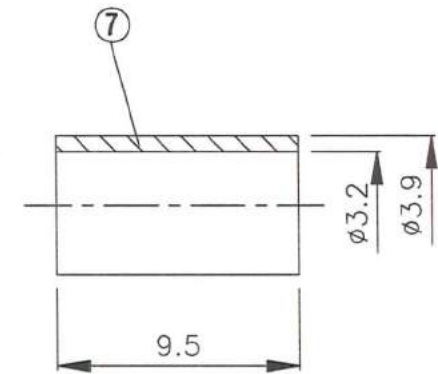
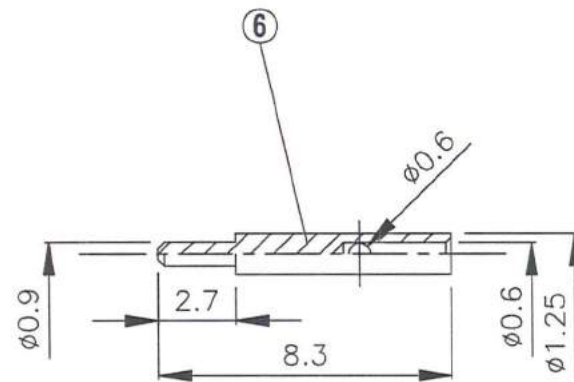
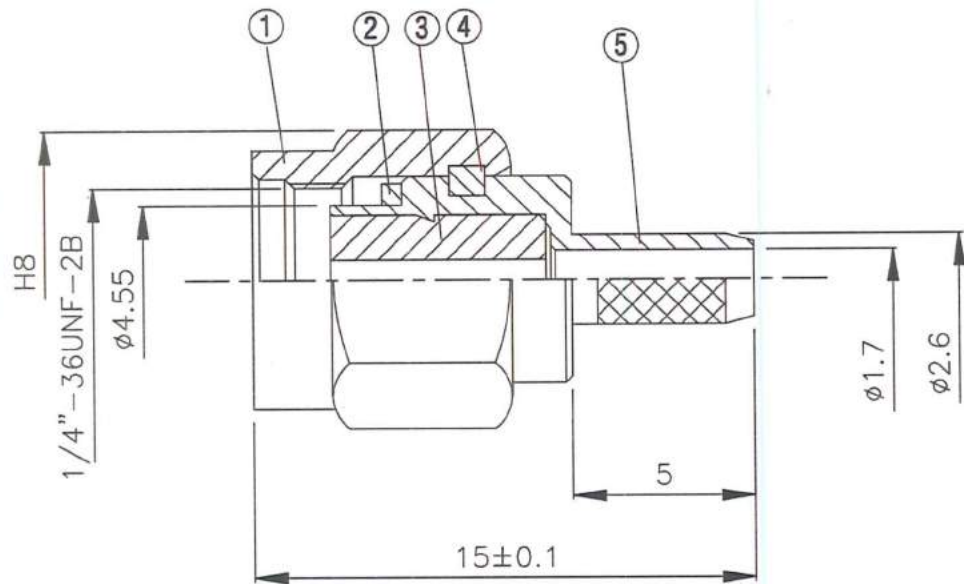
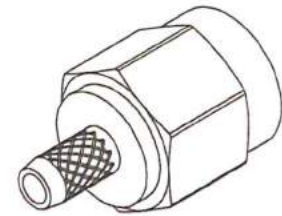

Working Voltage: 250 Volts rms max.

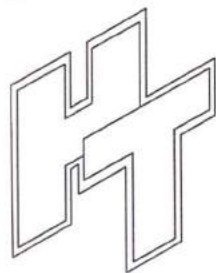

HUS-TSAN GROUP CO., LTD.

P.O. BOX 40-76. TAINAN. TAIWAN, R.O.C.

TITLE SMA MALE CRIMP FOR
RG174U, RG316U Series SMA-03

PART NO. SMA-03LV1-TGG

DRAWING NO. SMA-03LV1-TGG

DRAWN	MARY	DATE	96.03.15
CHECKED	蘇志欣	DATE	97.05.20
Q.A.	蘇姿潔	DATE	
APPROVAL	徐燦霖	DATE	
REVISION		DATE	

DIMENSIONS ARE IN MILLIMETERS

UNLESS OTHERWISE SPECIFIED
TOLERANCE

0.5-5=±0.2	120-315=±1
5-30=±0.4	315-1000=±1.6
30-120=±0.6	1000-2000=±2.4

SCALE 4:1 SIZE A

REVISION

DESCRIPTION	ENGINEER

D

D

C

C

B

B

A

A