

NO	DESCRIPTION	MATERIAL	Q'TY	FINISH	REMARK
1	SHELL	BRASS	1	GOLD	B-SMA0043-G
2	GASKET	SI RUBBER	1	GOLD	RU-0008
3	WASHER	PH.BRONZE	1	GOLD	W-0012-G
4	INSULATION	TEFLON	1	TEFLON	I-0138T
5	PIN	BRASS	1	GOLD	P-SMA0065-G
6	BODY	BRASS	1	GOLD	B-SMA0486-G
7	INSULATION	TEFLON	1	TEFLON	I-0136T
8	WASHER	GOLD	1	GOLD	W-0023-G
9	BODY	BRASS	1	GOLD	B-SMA0154-G

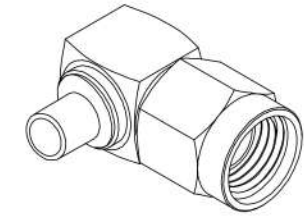

(Recommended Stripping Dimension)

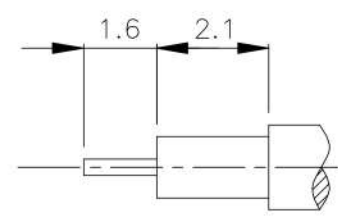
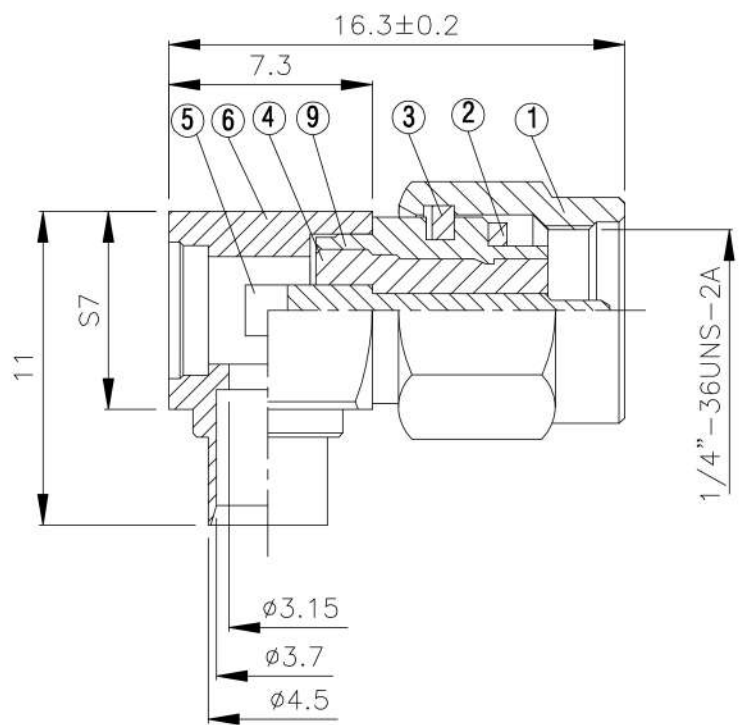
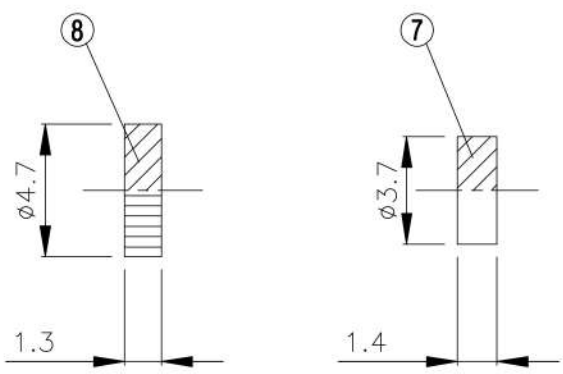

Nominal voltage: 250V

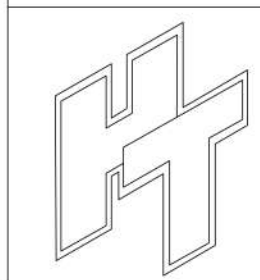

**HUS-TSAN GROUP CO., LTD.**  
P.O.BOX 40-76.TAINAN.TAIWAN,R.O.C.  
**TITLESMA MALE SOLDER FOR RG 402 (.141)**  
Series SMA-02  
**PART NO. SMA-02V2-TGG**  
**DRAWING NO. SMA 02V2 TGG**

DRAWN	MARY	DATE	95.11.01
CHECKED	蘇志欣	DATE	97.07.04
Q.A.	蘇姿潔	DATE	
APPROVAL	徐燦霖	DATE	
REVISION		DATE	

DIMENSIONS ARE IN MILLIMETERS			
UNLESS OTHERWISE SPECIFIED TOLERANCE			
0.5-5=±0.2	120-315=±1		
5-30=±0.4	315-1000=±1.6		
30-120±0.6	1000-2000=±2.4		
SCALE	4:1	SIZE	A

REVISION	
DESCRIPTION	ENGINEER