

NO	DESCRIPTION	MATERIAL	Q'TY	FINISH	REMARK
1	SHELL	BRASS	1	GOLD	B-SMA0043-G
2	GASKET	SI RUBBER	1	RUBBER	RU-0008
3	WASHER	PH.BRONZE	1	NICKEL	W-0012
4	INSULATION	TEFLON	1	TEFLON	I-0138T
5	PIN	BE CU	1	GOLD	P-SMA0718-G
6	BODY	BRASS	1	GOLD	B-SMA0808-G
7	INSULATION	TEFLON	1	TEFLON	I-0136T
8	WASHER	BRASS	1	NICKEL	W-0023-N
9	BODY	BRASS	1	GOLD	B-SMA0154-G
10	RING	BRASS	1	GOLD	R-0064-G

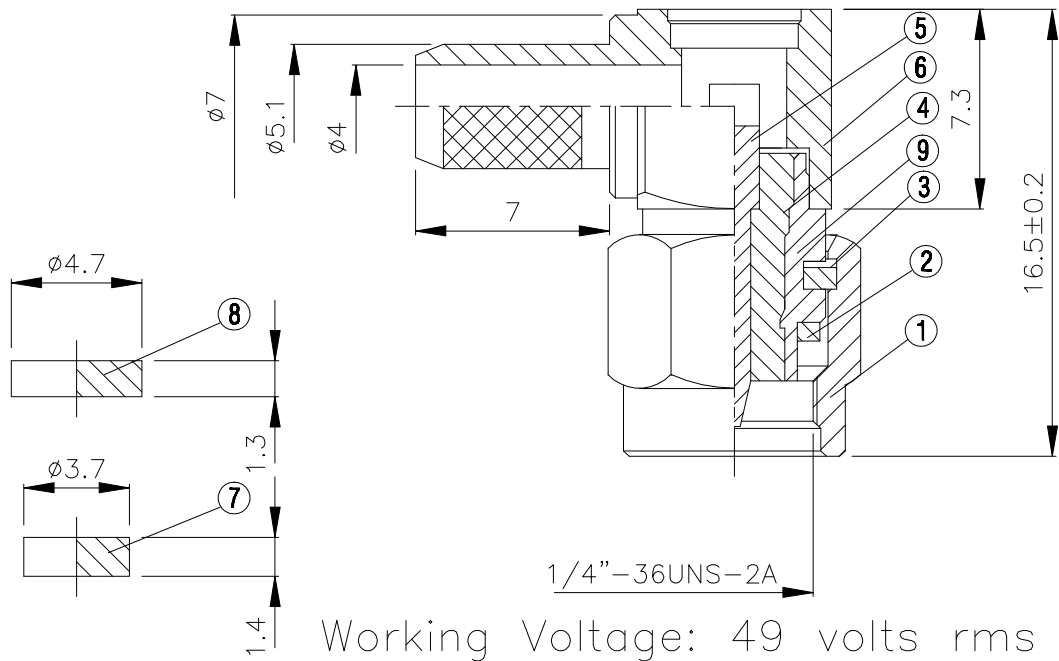
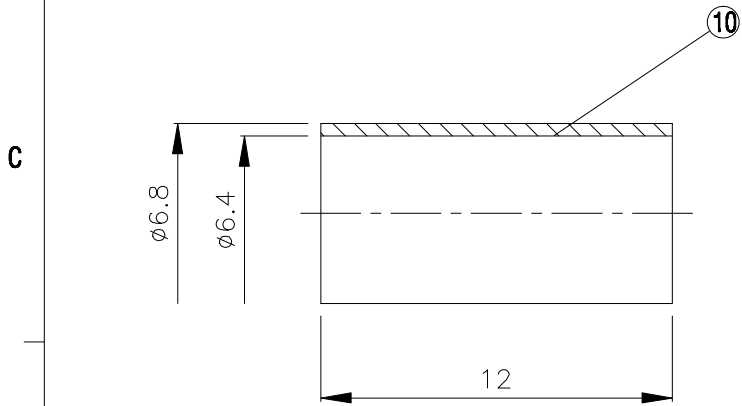
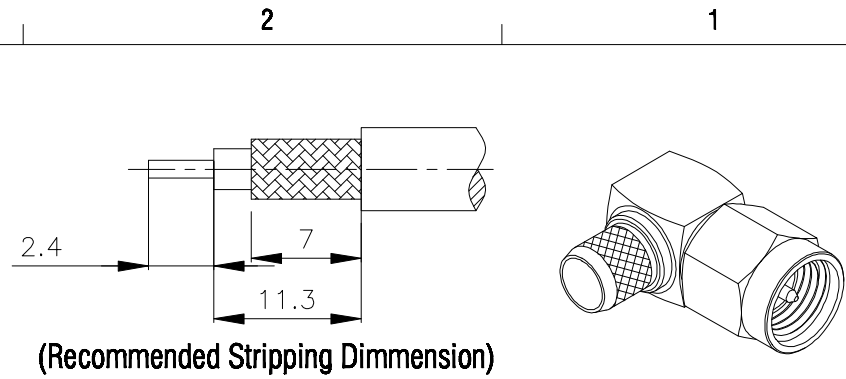
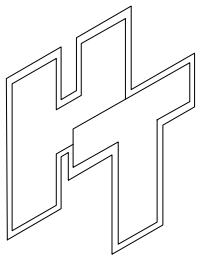

	HUS-TSAN GROUP CO., LTD.		DRAWN	MARY	DATE	94.12.10		DIMENSIONS ARE IN MILLIMETERS		REVISION	
	P.O.BOX 40-76.TAINAN.TAIWAN,R.O.C.		CHECKED	沈佳德	DATE	94.12.10		UNLESS OTHERWISE SPECIFIED TOLERANCE		DESCRIPTION	ENGINEER
	TITLE SMA MALE ANGLE CRIMP FOR LMR-240		Q.A.	蘇姿潔	DATE			0.5-5=±0.2 120-315=±1			
	PART NO. SMA-02R-TGG		APPROVAL	徐燦霖	DATE			5-30=±0.4 315-1000=±1.6			
	DRAWING NO. SMA-02R-TGG		REVISION		DATE			30-120=±0.6 1000-2000=±2.4			
					SCALE	4:1	SIZE	A			

4

3

2

1