

SPECIFICATION

1.General Characteristics
 SD Card 9P SMT 90° Push Push Type Standoff
 0.0/mm Normal Tape & Reel 400 PCS/Reel

2.Material&Finish
 Insulator:LCP(UL94V-0),Black
 Contact:Phosphor Bronze,
 Gold Plated On Contact Area,Tin Plated On
 Solder Tails,Over Nickel
 Shell:Stainless,Gold Flash On Solder Tails,
 Nickel Plated Over All
 Ground:Phosphor Bronze,Tin Plated

3.Electrical Characteristics
 Current Rating:0.5A
 Operation Voltage:250V AC/DC
 Contact Resistance:100 Milliohms Max.
 Insulation Resistance:1000 Megohms Min. At 250V DC
 Dielectric Withstanding Voltage:500V AC/Minute

4.Mechanical Characteristics
 Mating Cycles:10000 Cycles, Spring Is Not Breaking

5.Environmental Characteristics
 Operating Temperature: -40°C~+80°C

6.RoHS Compliant

SDC 09 W P 00 1 - R4H - H
 (1) (2) (3) (4) (5) (6) (7) (8)

- (1) SDC:SD Card Connector
- (2) 09:No. Of Position
- (3) W:SMT Right Angle
- (4) P:Push Push Type
- (5) 00:Standoff 0mm
- (6) 1:Normal Type
- (7) R4H:Tape & Reel 400 PCS/Reel
- (8) H:RoHS Compliant

AUK A MEMBER OF AUK GROUP
太聯事業股份有限公司
AUK CONTRACTORS CO., LTD.

CATEGORY		APPROVED BY		UNLESS OTHERWISE SPECIFIED TOLERANCES ARE X. ±0.50 X.* ±5% .X ±0.25 .X* ±2% .XX ±0.15 .XX* ±1%
PART No. SDC09WP001-R4H-H		MEI		
DRAWING No. SDC09WP001-R4H-H		HAO		
SCALE	NONE	REV.	A4	
CHECKED BY		DRAWING BY		UNIT
HZF		HAO		mm
REV.		A4		

A4	Modify Data	HZF	03/21/2015
A3	Modify P/N:SDC09WP001-R4H5-H --> SDC09WP001-R4H-H	HZF	07/17/2014
A2	Modify Spec.	HZF	12/18/2013
A1	Modify Spec.	HZF	09/16/2013
A0	NEW RELEASE	HZF	09/06/2012
NO.REV.	REVISIONS	CHK	DATE

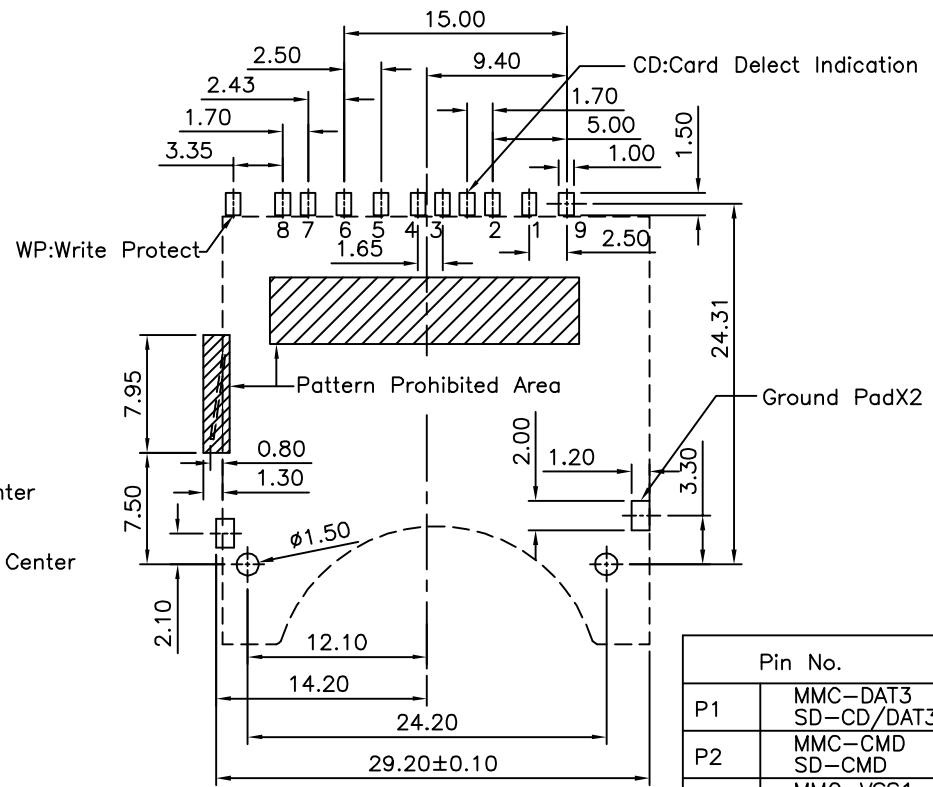
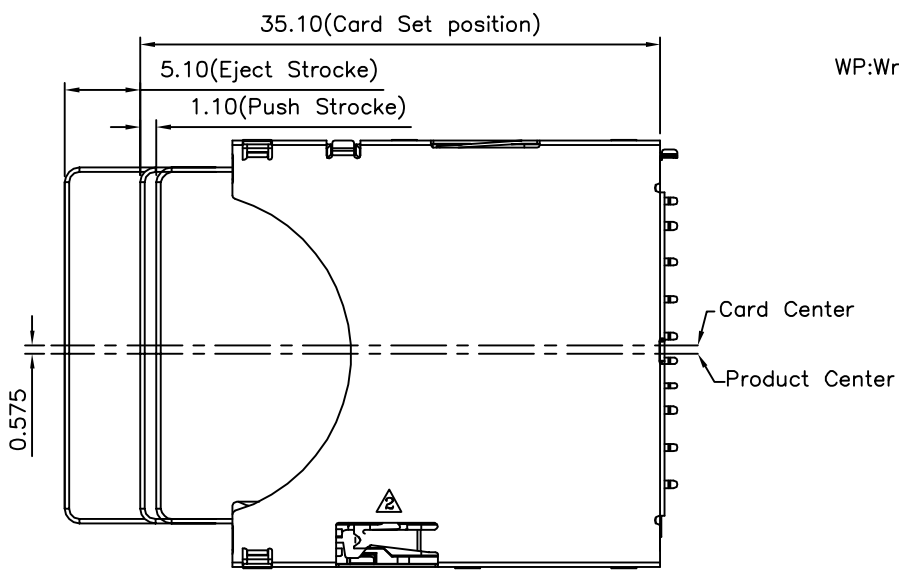

Recommended P.C.B. Layout
 (All Tolerance Are ±0.05)

Pin No.		SD	MMC
P1	MMC-DAT3 SD-CD/DAT3	1P	1P
P2	MMC-CMD SD-CMD	2P	2P
P3	MMC-VSS1 SD-VSS1	3P	3P
P4	MMC-VDD SD-VDD	4P	4P
P5	MMC-CLK SD-CLK	5P	5P
P6	MMC-VSS2 SD-VSS2	6P	6P
P7	MMC-DAT0 SD-DAT0	7P	7P
P8	SD-DAT1	8P	—
P9	SD-DAT2	9P	—

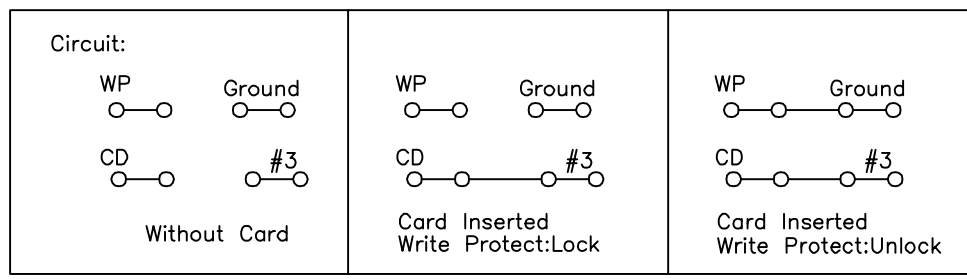

AUK A MEMBER OF AUK GROUP
太聯事業股份有限公司
AUK CONTRACTORS CO., LTD.

CATEGORY	APPROVED BY	MEI
PART No. SDC09WP001-R4H-H	CHECKED BY	HZF
DRAWING No. SDC09WP001-R4H-H	DRAWING BY	HAO
SCALE	REV.	A4

UNLESS OTHERWISE SPECIFIED TOLERANCES ARE
 X. ±0.50 X.* ±5*
 .X ±0.25 .X* ±2*
 .XX ±0.15 .XX* ±1*

UNIT mm

NO.	REV.	REVISIONS	CHK	DATE
A4		Modify Data	HZF	03/21/2015
A3		Modify P/N:SDC09WP001-R4H5-H --> SDC09WP001-R4H-H	HZF	07/17/2014
A2		Modify Spec.	HZF	12/18/2013
A1		Modify Spec.	HZF	09/16/2013
A0		NEW RELEASE	HZF	09/06/2012