

Constant Current Driver

Model : SC42W300-1050CG-4W
 SC42W300-1050CG-4B
 SC42W300-1050CG-4G



Model	Output Current	Input Current	Input Power	Output Power Range	PF	Efficiency	Output Voltage	No load Voltage
SC42W300-1050CG-4W SC42W300-1050CG-4B SC42W300-1050CG-4G	300mA	0.08A	14.48W	3.00-12.60W	0.86	87%	10-42V	59V
	350mA	0.09A	16.70W	3.50-14.70W	0.87	88%	10-42V	59V
	400mA	0.11A	19.10W	4.00-16.80W	0.88	88%	10-42V	59V
	450mA	0.12A	21.48W	4.50-18.90W	0.89	88%	10-42V	59V
	500mA	0.13A	23.60W	5.00-21.00W	0.90	89%	10-42V	59V
	550mA	0.14A	25.96W	5.50-23.10W	0.91	89%	10-42V	59V
	600mA	0.15A	30.40W	6.00-25.20W	0.92	89%	10-42V	59V
	650mA	0.16A	30.67W	6.50-27.30W	0.93	89%	10-42V	59V
	700mA	0.17A	33.03W	7.00-29.40W	0.94	89%	10-42V	59V
	750mA	0.18A	35.40W	7.50-31.50W	0.94	89%	10-42V	59V
	800mA	0.20A	37.75W	8.00-33.60W	0.95	89%	10-42V	59V
	850mA	0.21A	38.20W	8.50-34.00W	0.95	89%	10-40V	59V
	900mA	0.22A	40.45W	9.00-36.00W	0.96	89%	10-40V	59V
	950mA	0.22A	42.70W	9.50-38.00W	0.96	89%	10-40V	59V
	1000mA	0.23A	44.95W	10.00-40.00W	0.97	89%	10-40V	59V
1050mA	0.23A	47.20W	10.50-42.00W	0.97	89%	10-40V	59V	

* Test result @230V, 50Hz, Full Load.

1. Parameters

Category	Item	Technical Norm
Features	Output Type	Constant Current
	Output Features	Isolation
	IP Grade	IP20
	Insulation Class	Class II
Input	Rated Input Voltage	220-240VAC
	Range of Input Voltage	176-264VAC or 176-280VDC
	Frequency	50/60Hz

	Input Current	≤0.23A (230VAC, full load)
	Input Power	≤47.2W (230VAC, full load)
	Power Factor	≥0.97(230VAC, full load)
	THD	≤20% (230VAC, full load)
	No-load Power Consumption	≤0.5W @230VAC
Output	Output Voltage Range	10-42VDC@300-800mA 10-40VDC@850-1050mA
	No Load Voltage	59VDC Max.
	Output Current	300mA -1050mA (Max. output)
	Max. Output Power	42W
	Efficiency	≥89% (230VAC, full load)
	Current Ripple	±5% (Imax-Imin)/(Imax+Imin)
	Current Accuracy	±5%
	Started Delay Time	≤0.5S (230VAC, full load)
	PstLM	≤1
	SVM	≤0.4
Protection	Short Circuit Protection	Auto Recovery
	Overload Protection	Auto Recovery
	No-load Protection	Auto Recovery
	Insulation voltage	3000V 5mA 60S between P-S
	Insulation resistance	>100M ohm @ 500VDC
	Leakage current	< 250µA, I/P to O/P or I/P to PE @230V input
Environment	Ta/Operation Temperature	-20....+35°C
	Ts/Storage Temperature	-40....+75°C
	Tc/Enclosure Temperature	70°C
	Humidity	10%....90%RH
	Atmospheric pressure	86-108KPa
Construction	Connection Method	Push-in Terminal
	Installation	Independent
	SEC Wire preparation	0.5-1.5 [□]
	Dimension	158 x 31 x 45mm (L*W*H)
Standards	Certification	ENEC/CE/ SAA
	Safety Standards	EN61347-1:2015,EN61347-2-13:2014/A1:2017, EN62384:2006/A1:2009,AS61347.2.13:2018, AS/NZS 61347.1:2016 Inc A1
	EMC Standards	EN IEC 55015:2019,EN IEC 55015:2019/A11:2019, EN IEC 61000-3-2:2019, EN 61000-3-3:2013/A1:2019 EN61547:2009
	Performance	EN62384
	Surge	L-N/2KV
Others	RoHS	complied to 2011/65/EU
	Life Time	50000h @Ta/ Tc
	Warranty	5years , F.R. < 10000ppm

Noise	≤ 24dB @Background noise ≤18dB , Interval≥15cm
-------	--

Remark:

- 1.All Parameters, if not specified, are measured at 230VAC/50Hz and 25°C ambient temperature.
- 2.LED Driver is a component of the luminaires, Luminaires and wire layout will affect the EMC, please check the EMC with end products again.

2. Output Current Setting

Output Current	1	2	3	4
300mA	-	-	-	-
350mA	-	-	-	ON
400mA	-	-	ON	-
450mA	-	-	ON	ON
500mA	-	ON	-	-
550mA	-	ON	-	ON
600mA	-	ON	ON	-
650mA	-	ON	ON	ON
700mA	ON	-	-	-
750mA	ON	-	-	ON
800mA	ON	-	ON	-
850mA	ON	-	ON	ON
900mA	ON	ON	-	-
950mA	ON	ON	-	ON
1000mA	ON	ON	ON	-
1050mA	ON	ON	ON	ON

3. Connected quantities of different current Breaker

TYPE	Connected quantities of different current Breaker					Input Voltage	Inrush Current	Time
	current (A)	10	13	16	20			
	Installation wire diameter	1.5mm ²	2.5mm ²	2.5mm ²	4mm ²	4mm ²		
TYPE B		33	43	53	67	83	@230VAC	18
TYPE C		53	69	85	107	133		
TYPE D		85	111	137	171	213		

4. Label

EAC **KGP** PRI:220-240VAC 50/60Hz Max.0.23A
 KGP Electronics GmbH Huelckstraße 19 DE-58511 Lüdenscheid
 SEC:300-800mA 10-42VDC
 850-1050mA 10-40VDC
 LED Driver NO Load:59VDC Max.42W Fmax.50N
 SC42W300-1050CG-4W tc:75°C ta:35°C
 For LED modules only
 Constant Current Lighting track adaptors

UK CA SELV

0.5-1.5 8-9mm 1 2 3 4

Pout [W]	Iout [mA]	λ	1	2	3	4	Pout [W]	Iout [mA]	λ	1	2	3	4
12.6	300	0.86C	-	-	-	-	29.4	700	0.94C	ON	-	-	-
14.7	350	0.87C	-	-	-	ON	31.5	750	0.94C	ON	-	-	ON
16.8	400	0.88C	-	-	ON	-	33.6	800	0.95	ON	-	ON	-
18.9	450	0.89C	-	-	ON	ON	34	850	0.95	ON	-	ON	ON
21	500	0.90C	-	ON	-	-	36	900	0.96	ON	ON	-	-
23.1	550	0.91C	-	ON	ON	-	38	950	0.96	ON	ON	-	ON
25.2	600	0.92C	-	ON	ON	-	40	1000	0.97	ON	ON	-	ON
27.3	650	0.93C	-	ON	ON	ON	42	1050	0.97	ON	ON	ON	ON

EAC **KGP** PRI:220-240VAC 50/60Hz Max.0.23A
 KGP Electronics GmbH Huelckstraße 19 DE-58511 Lüdenscheid
 SEC:300-800mA 10-42VDC
 850-1050mA 10-40VDC
 LED Driver NO Load:59VDC Max.42W Fmax.50N
 SC42W300-1050CG-4B tc:75°C ta:35°C
 For LED modules only
 Constant Current Lighting track adaptors

UK CA SELV

0.5-1.5 8-9mm 1 2 3 4

Pout [W]	Iout [mA]	λ	1	2	3	4	Pout [W]	Iout [mA]	λ	1	2	3	4
12.6	300	0.86C	-	-	-	-	29.4	700	0.94C	ON	-	-	-
14.7	350	0.87C	-	-	-	ON	31.5	750	0.94C	ON	-	-	ON
16.8	400	0.88C	-	-	ON	-	33.6	800	0.95	ON	-	ON	-
18.9	450	0.89C	-	-	ON	ON	34	850	0.95	ON	-	ON	ON
21	500	0.90C	-	ON	-	-	36	900	0.96	ON	ON	-	-
23.1	550	0.91C	-	ON	ON	-	38	950	0.96	ON	ON	-	ON
25.2	600	0.92C	-	ON	ON	-	40	1000	0.97	ON	ON	-	ON
27.3	650	0.93C	-	ON	ON	ON	42	1050	0.97	ON	ON	ON	ON

EAC **KGP** PRI:220-240VAC 50/60Hz Max.0.23A
 KGP Electronics GmbH Huelckstraße 19 DE-58511 Lüdenscheid
 SEC:300-800mA 10-42VDC
 850-1050mA 10-40VDC
 LED Driver NO Load:59VDC Max.42W Fmax.50N
 SC42W300-1050CG-4G tc:75°C ta:35°C
 For LED modules only
 Constant Current Lighting track adaptors

UK CA SELV

0.5-1.5 8-9mm 1 2 3 4

Pout [W]	Iout [mA]	λ	1	2	3	4	Pout [W]	Iout [mA]	λ	1	2	3	4
12.6	300	0.86C	-	-	-	-	29.4	700	0.94C	ON	-	-	-
14.7	350	0.87C	-	-	-	ON	31.5	750	0.94C	ON	-	-	ON
16.8	400	0.88C	-	-	ON	-	33.6	800	0.95	ON	-	ON	-
18.9	450	0.89C	-	-	ON	ON	34	850	0.95	ON	-	ON	ON
21	500	0.90C	-	ON	-	-	36	900	0.96	ON	ON	-	-
23.1	550	0.91C	-	ON	ON	-	38	950	0.96	ON	ON	-	ON
25.2	600	0.92C	-	ON	ON	-	40	1000	0.97	ON	ON	-	ON
27.3	650	0.93C	-	ON	ON	ON	42	1050	0.97	ON	ON	ON	ON

5. Lifetimecurve

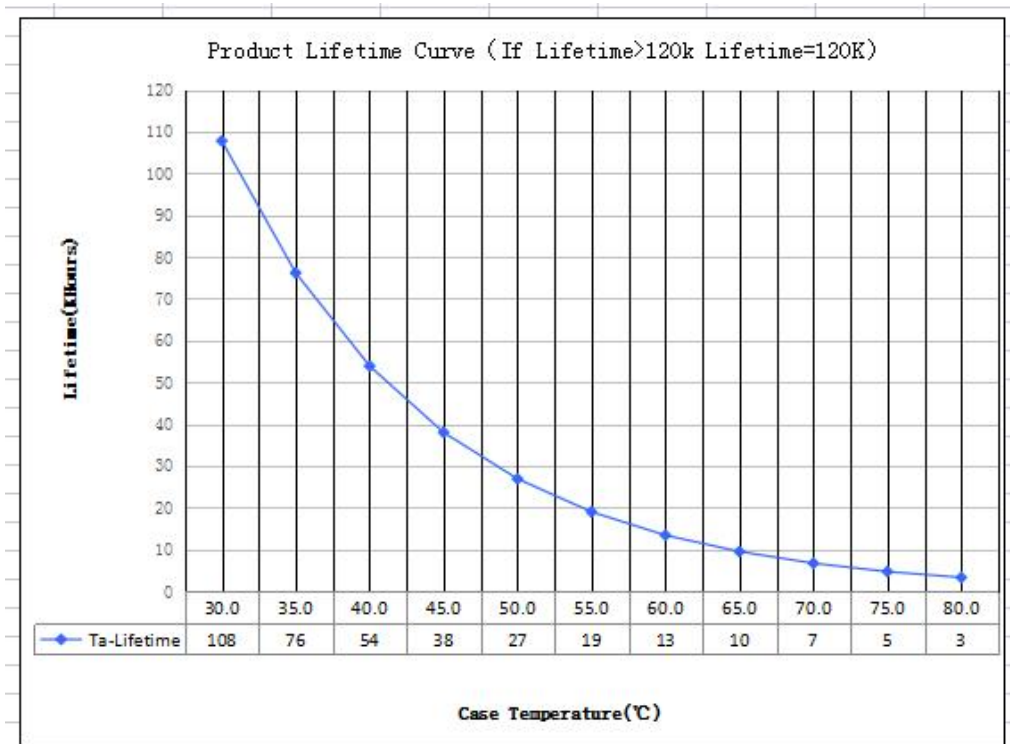

6. Dimension

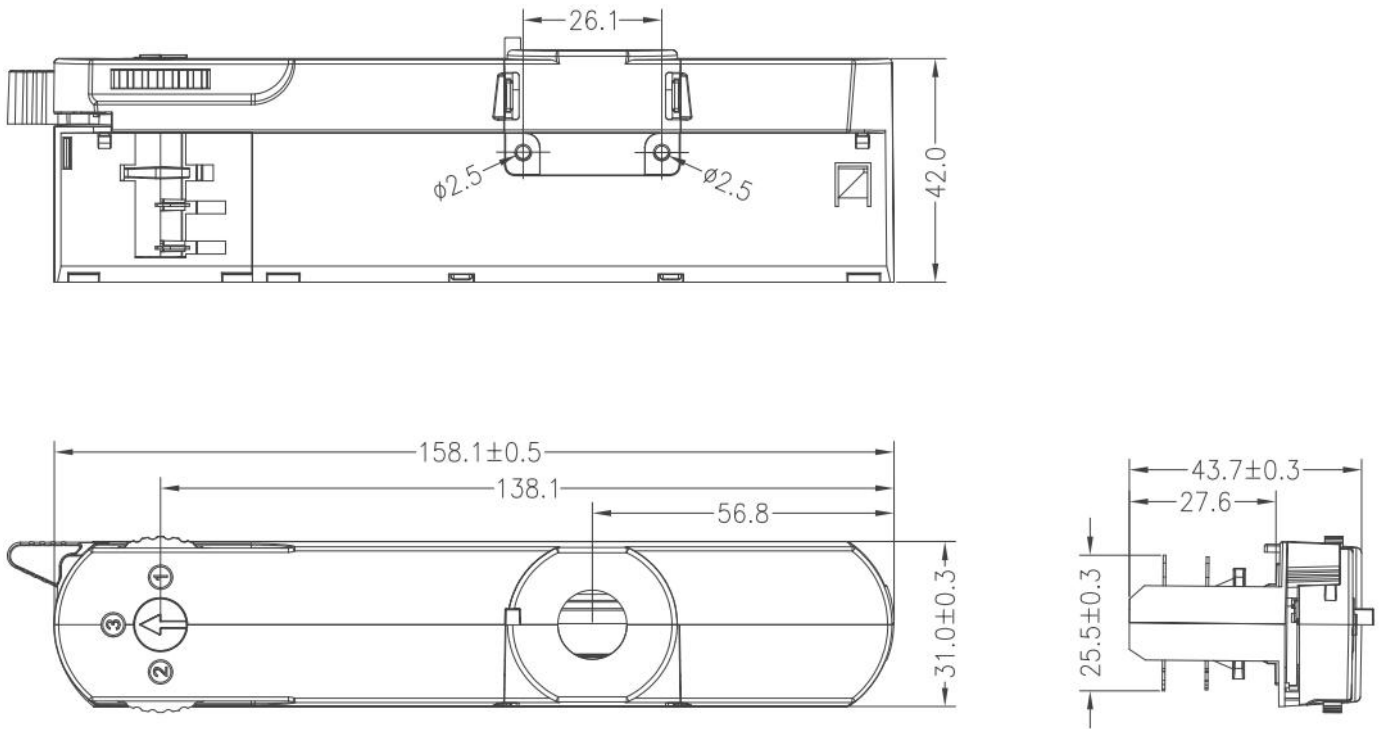

7. Packing information

Packing way	Model	Colour	Carton L*W*H(mm)	Pcs/ Carton	Net weight/ Pcs(kg)	Net weight/ Carton(kg)	Gross weight/ Carton(kg)
industrial	SC42W300-1050CG-4W	White	515*274*370	150	0.125	18.75	20.07
	SC42W300-1050CG-4B	Black					
	SC42W300-1050CG-4G	Grey					

8. Wiring Diagram

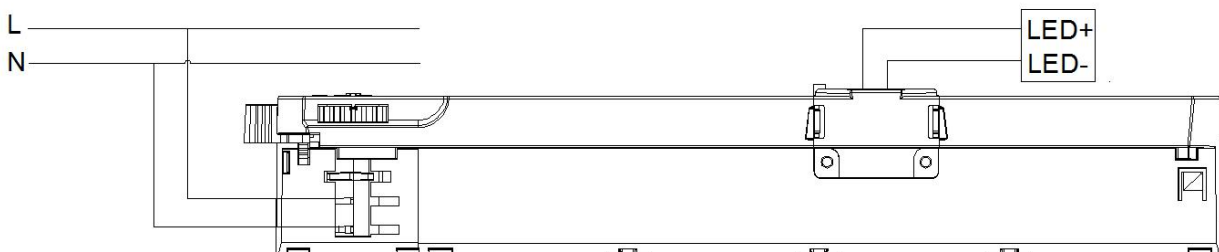

9. Lamp Screw Type

- Optional threaded sleeve for luminaire mounting
- Suitable for M10x1x8 threaded nut
- Additional mounting equipment, e.g. M10x1x12
- aluminium, black, white
- further on request

Ordering data

Type	Colour	Article number	Qty/ctn	Weight/pcs
M10x8	White	AL	PC	9.04
	Black	AL	PC	9.04
	Gray	AL	PC	9.04
M10x12	White	AL	PC	9.72
	Black	AL	PC	9.72
	Gray	AL	PC	9.72

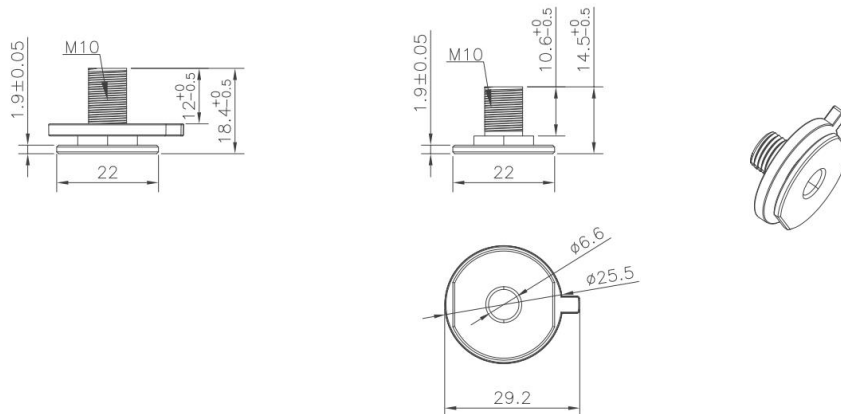

10. Suitable for following tracks

Serial number	Brand	Track model	System
1	Global	XTS11 & XTSC611	3P
2	A.A.G STUCCHI	9000-1-ST	3P
3	Eutrac	25-106	3P
4	Unipro	T32B	3P
5	PowerGEAR	Pro-0431L&Pro-D631R	3P
6	ERCO	1079301000	3P
7	BELINIEGRA	4X	3P

Remark:

1. The model name is XTS11 and XTSC611 tracks, and its brand is Global.
2. The model name used is the 9000-1-ST track, and its brand is A.A.G STUCCHI.
3. The model name is 25-106 tracks, and its brand is Eutrac.

4. The model name is T32B tracks, and its brand is Unipro.
5. The model name is Pro-0431L and Pro-D631R tracks, and its brand is PowerGEAR.
6. The model name is 1079301000 tracks, and its brand is ERCO.
7. The model name is 4X tracks, and its brand is BELINIEGRA

11. Phase track light rail specification:

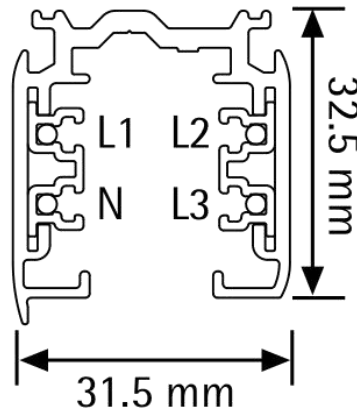

12. Lighting track adapter and rail system installation diagram:

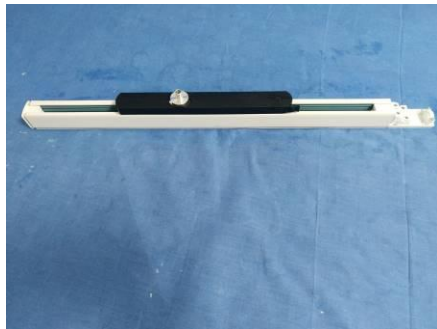

The adaptor shall be given that the use is limited to the track system specified.

13. Wiring instructions

- All connections must be kept as short as possible to ensure good EMI behaviour
- Mains leads should be kept apart from LED Driver and other leads (ideally 5 – 10 cm distance)
- Advice the maximum length of output wires is 3 m
- Secondary switching is not permitted (Except for constant voltage)
- Incorrect wiring can damage LED modules.
- The wiring must be protected against short circuits to earth (sharp edged metals parts, metal cable clips, louver, etc.)