



Constant Current Dimmable Driver

Model: RCXXWXXX Triac



Model	Output Current	Input Current	Input Power	Output Power Range	PF	Efficiency	Output Voltage	No load Voltage
RC21W300 Triac	300mA	0.13A	28W	13.5-18W	0.92	84%	45-60V	75V
RC21W350 Triac	350mA	0.13A	28W	15.75-21W	0.92	84%	45-60V	75V
RC21W400 Triac	400mA	0.13A	28W	14.4-20.8W	0.92	84%	36-52V	65V
RC21W450 Triac	450mA	0.13A	28W	13.5-18.9W	0.92	84%	30-42V	55V
RC21W500 Triac	500mA	0.13A	28W	15-21W	0.92	84%	30-42V	55V
RC21W550 Triac	550mA	0.13A	28W	16.5-20.9W	0.92	84%	30-38V	50V
RC24W500 Triac	500mA	0.15A	33W	18-25W	0.92	84%	36-50V	65V
RC24W550 Triac	550mA	0.15A	33W	14.85-23.1W	0.92	84%	27-42V	55V
RC24W600 Triac	600mA	0.15A	33W	16.2-24W	0.92	84%	27-40V	55V
RC24W700 Triac	700mA	0.15A	33W	13.3-21W	0.92	83%	19-30V	45V
RC24W800 Triac	800mA	0.15A	33W	15.2-24W	0.92	83%	19-30V	45V
RC26W1000 Triac	1000mA	0.18A	35W	16-26W	0.92	83%	16-26V	42V
RC28W600 Triac	600mA	0.18A	36W	21.6-28.8W	0.92	85%	36-48V	60V
RC28W650 Triac	650mA	0.18A	36W	17.55-27.3W	0.92	85%	27-42V	55V
RC28W700 Triac	700mA	0.18A	36W	18.9-28W	0.92	85%	27-40V	55V

* Test result @230V, 50Hz, Full Load.

1. Parameters

Category	Item	Technical Norm
Features	Output Type	Constant Current
	Dimming Type	Phase dimming
	Dimming Range	10%-100%
	IP Grade	IP20
	Insulation Class	Class II
Input	Rated Input Voltage	220-240VAC_stable
	Range of Input Voltage	198-264VAC_stable or 180-280VDC_stable
	Frequency	50/60Hz
	Input Current	≤0.18A

	Input Power	≤ 36W
	Power Factor	≥0.92 (230VAC,full load)
	THD	≤20% (230VAC,full load)
Output	Current Accuracy	±5%
	Max. Output Power	28.8W
	Started Delay Time	≤0.5S (230VAC,full load)
	Current Ripple(< 120 Hz)	±5% (Imax-Imin) / (Imax+Imin)
	PstLM	≤1
	SVM	≤0.4
Protection	Short Circuit Protection	Auto Recovery
	Overload Protection	Auto Recovery
	No-load Protection	Auto Recovery
	Insulation voltage	I/P to O/P , 3KVac/1min
	Insulation resistance	>100M ohm @ 500VDC
	Leakage current	I/P to O/P < 250μA
Environment	Ta/Operation Temperature	-20....+60℃
	Ts/Storage Temperature	-40....+85℃
	Tc/Enclosure Temperature	90 ℃
	Humidity	10%.... 90%RH
	Atmosphere	86-108KPa
Construction	Connection Method	Direct Lead
	Installation	Build-in
	PRI Wire preparation	0.5-1.5 [□]
	SEC Wire preparation	0.5-1.5 [□]
	Dimension	Φ57X25.5mm (R*H)
Standards	Certification	TUV、 CE、 SAA
	Safety Standards	EN61347-1:2015,EN61347-2-13:2014/A1:2017, EN62493:2015,AS/NZS IEC61347.2.13:2018, AS/NZS61347.1:2016 Inc AI
	EMC Standards	EN IEC 55015:2019,EN IEC 55015:2019/A11:2019, EN IEC 61000-3-2:2019, EN 61000-3-3:2013/A1:2019,EN61547:2009
	Performance	EN62384
	Surge	L-N/ 2KV
Others	RoHS	complied to 2011/65/EU
	Life Time	50000h @ (Ta) / (Tc)
	Warranty	5years , F.R. < 10000ppm
	Noise	≤ 28dB@Background noise ≤18dB , Interval≥15cm
Remark 1. All Parameters, if not specified, are measured at 230VAC/50Hz and 25℃ ambient temperature. 2. LED Driver is a component of the luminaires. Luminaires and wire layout will affect the EMC, please check the EMC with end products again.		

2. Trailing Edge Dimmer list approved by KGP

Manufacturer	Model	Q'ty of parallel connection
ABB	6519 U	12
ABB	6526 U	13
JUNG	1224 LED UDE	11
Berker	2861	12
JUNG	254 UDIE 1	13
JUNG	225 TDE	13
EGANT	U321V2	12
Schneider	SBD200LED	13
Schneider	SBD315RC	12
Merten	SBD200LED	13
Berker	2874	12

Leading Edge Dimmer list only on request -/ or confirmed by KGP Electronics

3. Connected quantities of different current Breaker

TYPE	Connected quantities of different current Breaker						Input Voltage	Inrush Current	Time
	current (A)	10	13	16	20	25			
	Installation wire diameter	1.5mm ²	2.5mm ²	2.5mm ²	4mm ²	4mm ²			
TYPE B		24	31	38	48	60	@230VAC	25	500us
TYPE C		38	50	61	77	96			
TYPE D		61	80	98	123	154			

4. Label (For example)



5. Dimming curve

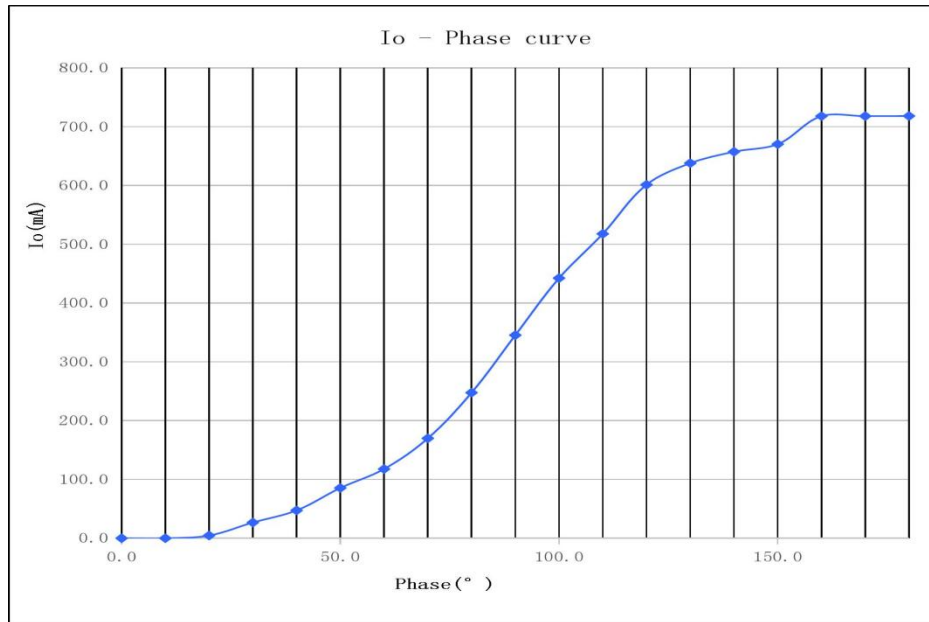

6. Lifetime curve

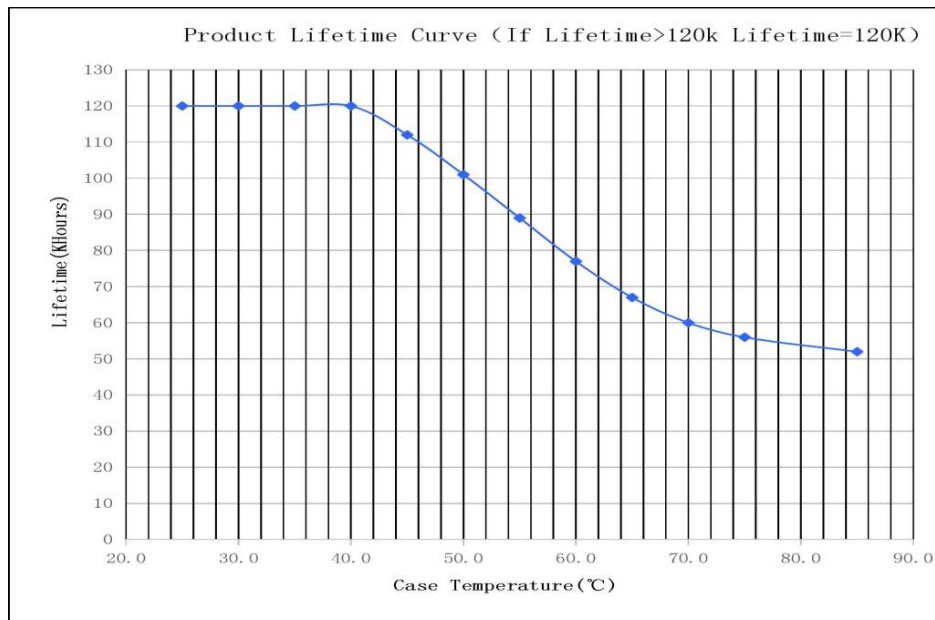

7. Dimension (Unit: mm)

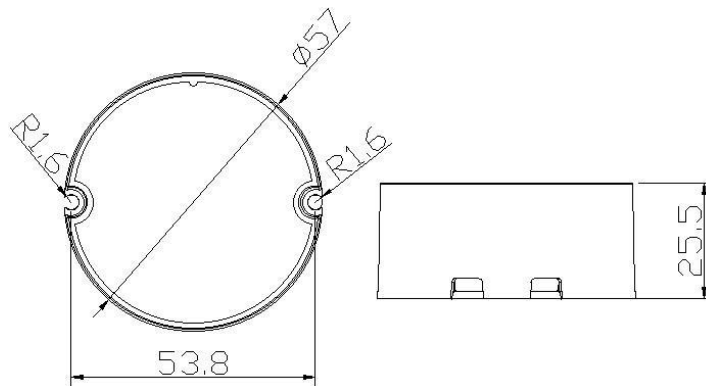

8. Wiring Diagram

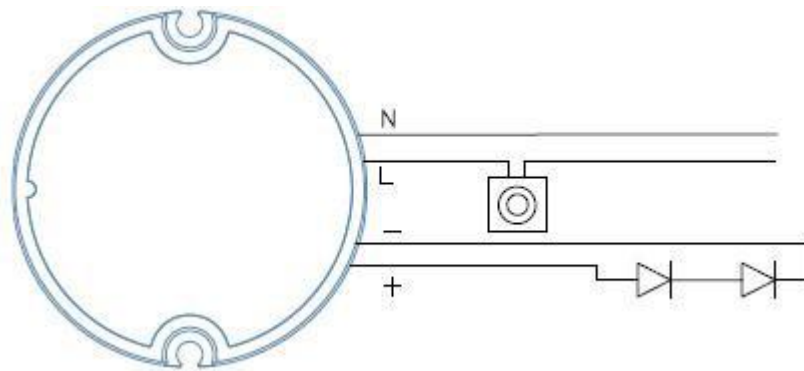

9. Packing information

Packing way	Model	Carton L*W*H(mm)	Pcs/ Carton	Net weight/ Pcs(kg)	Net weight/ Carton(kg)	Gross weight/ Carton(kg)
With white box and manual	RCXXWXXX Triac	435*280*210	110	0.108	11.88	12.65
Without white box and manual		420*280*180	120	0.108	12.96	13.58

10. Wiring instructions

- All connections must be kept as short as possible to ensure good EMI behaviour
- Mains leads should be kept apart from LED Driver and other leads (ideally 5 – 10 cm distance)
- Advice the maximum length of output wires is 3 m
- Secondary switching is not permitted (Except for constant voltage)
- Incorrect wiring can damage LED modules.
- The wiring must be protected against short circuits to earth (sharp edged metals parts, metal cable clips, louver, etc.)