



RC18W300-700 DALI NFC

Constant Current Dimmable Driver

Model: RC18W300-700 DALI NFC



Model	Output Current	Input Current	Input Power	Output Power Range	PF	Efficiency (*Typical)	Output Voltage	No load Voltage
RC18W300-700 DALI NFC	300mA	0.09A	17.5W	0.75-14.4W	≥0.88	84%	2.5-48V	60V
	400mA	0.095A	24.7W	1.00-18W	≥0.9	84%	2.5-45V	
	500mA	0.095A	24.7W	1.25-18W	≥0.9	84%	2.5-36V	
	600mA	0.095A	24.7W	1.50-18W	≥0.9	82%	2.5-30V	
	700mA	0.095A	24.7W	1.75-17.5W	≥0.9	82%	2.5-25V	

* Test result @230V, 50Hz, Full Load. Current setting @ 1mA-steps (NFC)

1. Parameters

Category	Item	Technical Norm
Features	Output Type	Constant Current
	Dimming Type	DALI-2
	Output Features	Isolation
	IP Grade	IP20
	Insulation Class	Class II
Input	Rated Input Voltage	220-240VAC
	Range of Input Voltage	198-264VAC or 180-280VDC
	Frequency	0/50/60Hz
	Input Current	≤0.095A (230VAC, full load)
	Input Power	≤24.7W (230VAC, full load)
	Power Factor	≥0.9 (230VAC, full load)
	THD	≤15% (230VAC, full load)
	No-load Power Consumption	≤0.5W Dim to off, 230VAC
	Inrush Current	≤50A/10us (230VAC, full load)
Output	Output Voltage Range	2.5-48VDC@300mA
		2.5-45VDC@400mA
		2.5-36VDC@500mA
		2.5-30VDC@600mA
		2.5-25VDC@700mA
	No Load Voltage	60VDC Max.
	Output Current	300mA -700mA
Max. Output Power	18W	

	Efficiency	≥82% (230VAC full load@max current)
	Current Ripple(< 120 Hz)	±5% (Imax-Imin)/(Imax+Imin)
	PstLM	≤1
	SVM	≤0.4
	Current Accuracy	±5%
	Line Regulation	±5%
	Load Regulation	±5%
	Started Delay Time	≤1S(230VAC, full load)
	Emergency output coefficient	1
Control Method	Secondary PUSH dimming	Secondary PUSH dimming (Max. lead wire length : 20m,same port of DALI)
	PUSH dimming terminal	Max parallel connections qty for Push-dim 64 PCS
	DALI function	DALI dimming (Max. lead wire length: 300m) Logarithmic or linear dimming curves are available DALI-2 certified incl. Parts 251, 252, 253,CLO
	DALI Dimming range	DALI dimming: 1%-100%,Dim to off .
	Current Interface	Near field communication (NFC)
	Adjustable output current	1mA-steps (NFC)
Protection	Short Circuit Protection	Auto Recovery
	Overload Protection	Auto Recovery
	No-load Protection	Auto Recovery
	Insulation voltage	3000V 5mA 60S between P-S
	Insulation resistance	>100M ohm @ 500VDC
	Leakage current	I/P to O/P <0.7mA
Environment	Ta/Operation Temperature	-25....+50°C
	Ts/Storage Temperature	-25....+85°C
	Tc/Enclosure Temperature	85°C
	Humidity	10%....90%RH
	Atmosphere	86-108KPa
Construction	Connection Method	Direct Lead
	Installation	Built in
	Dimension	Φ55*25mm (R*H)
Standards	Certification	EL ENEC UKCA EAC CE SAA
	Safety Standards	EN 61347-1:2015/A1:2021 EN 61347-2-13:2014/A1:2017 EN IEC 62384:2020 AS61347.2.13:2018 AS/NZS61347.1:2016 Inc A1
	EMC Standards	EN IEC 55015:2019 EN IEC 55015:2019/A11:2020 EN IEC 61000-3-2:2019/A1:2021 EN 61000-3-3:2013/A2:2021 EN IEC 61547:2023
	RED	EN 300 330 V2.1.1:2017

		EN 301 489-1 V2.2.3:2019 EN 301 489-3 V2.3.2:2023 EN 62479:2010 EN 50663:2017
	Performance	EN62384:2020
	DALI performance	IEC 62386- 101 (ed2.0) IEC 62386- 102 (ed2.0) IEC 62386- 207 (ed1.0) IEC 62386- 251 (ed2.0) IEC 62386- 252 (ed2.0) IEC 62386- 253 (ed2.0)
	Surge	L-N/2KV
Others	RoHS	complied to 2011/65/EU
	REACH	EU Regulation (EC) No 1907/2006
	Life Time	50000h @Ta
	Warranty	5years
	Noise	≤ 22dB @Background noise ≤18dB ,Interval≥15cm

Remark:

1. All Parameters, if not specified, are measured at 230VAC/50Hz and 25°C ambient temperature.
2. LED Driver is a component of the luminaires, Luminaires and wire layout will affect the EMC, please check the EMC with end products again.
3. During the PUSH DIM test, the number of parallel connections must be less than 64 PCS
4. Do not install upside down.

2. Connected quantities of different current Breaker

RC18W300-700 DALI NFC

TYPE	Connected quantities of different current Breaker						Input Voltage (V)	Inrush Current(A)	Time (µs)
	current (A)	10	13	16	20	25			
	Installation wire diameter	1.5mm ²	2.5mm ²	2.5mm ²	4mm ²	4mm ²			
TYPE B	12	16	19	24	30	@230VAC	50	10	
TYPE C	19	25	31	38	48				
TYPE D	31	40	49	61	77				

3. Label

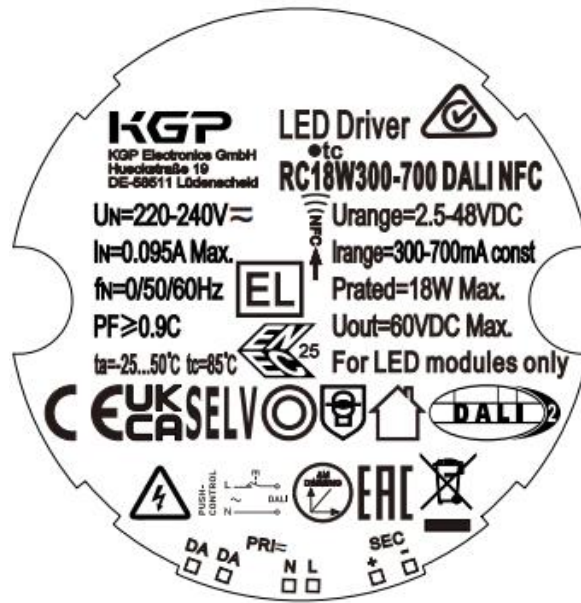

4. Dimming curve

formula for DALI dimming.

$$X(n) = 10^{\left\{ \left[\frac{(n-1)}{(253/3)} \right] - 1 \right\}}$$

Here, n means the target dimming stage of the total 254 stages.

X(n) means the percent of the maximum output current

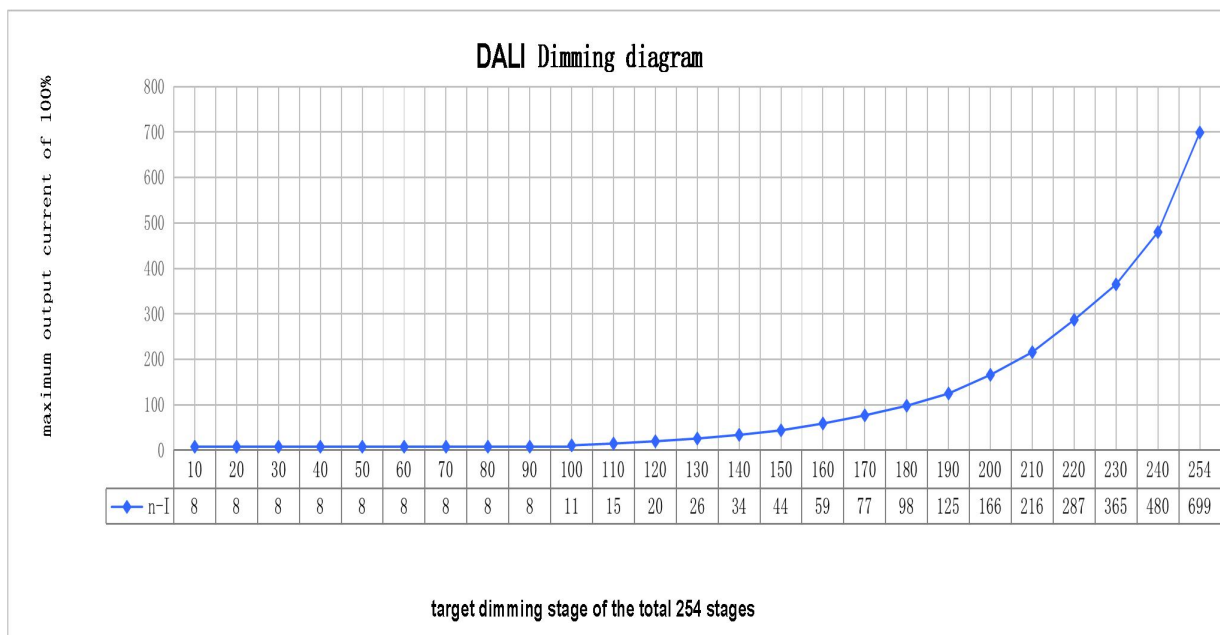

5. Electrical values

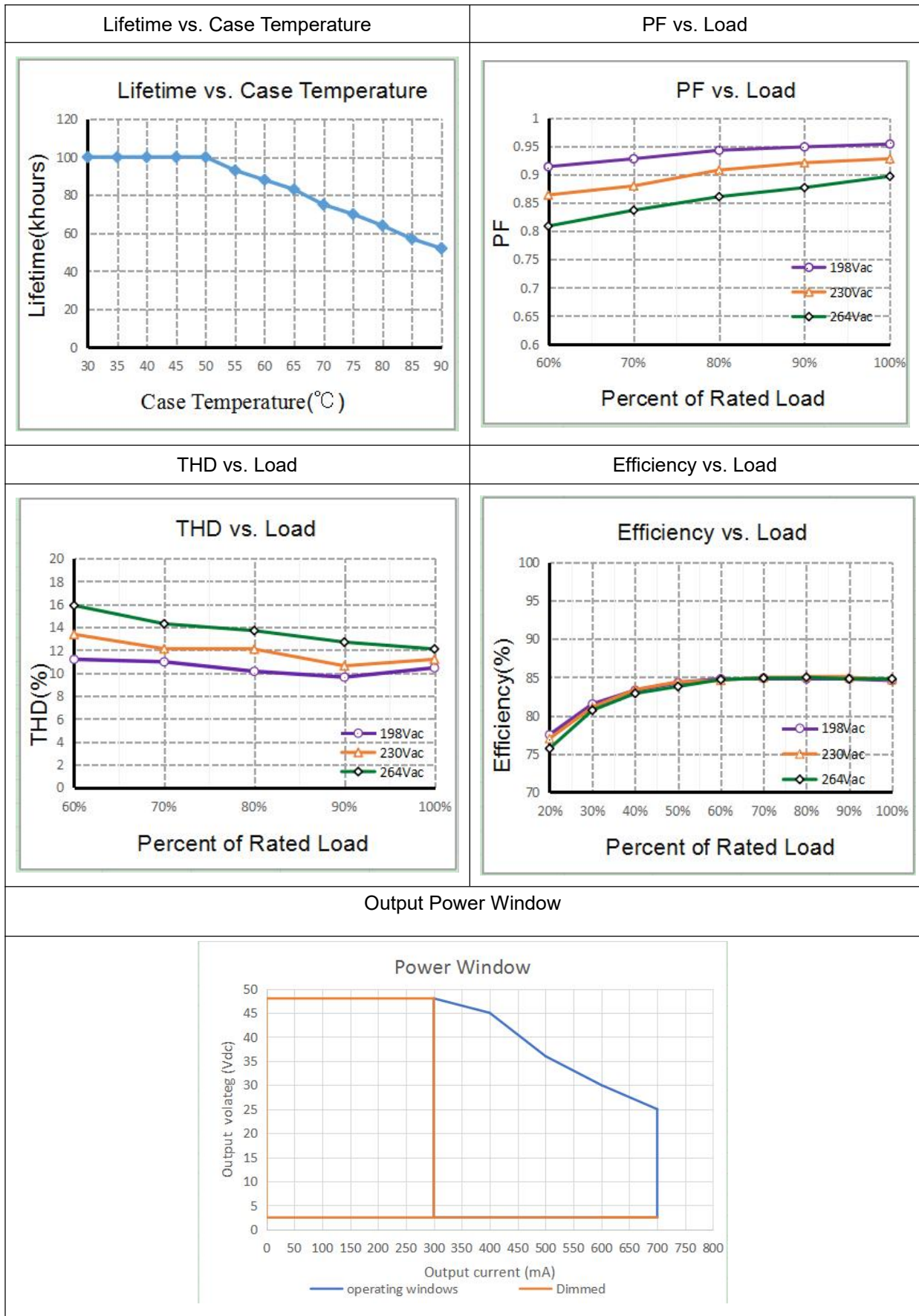

6. Dimension (Unit: mm)

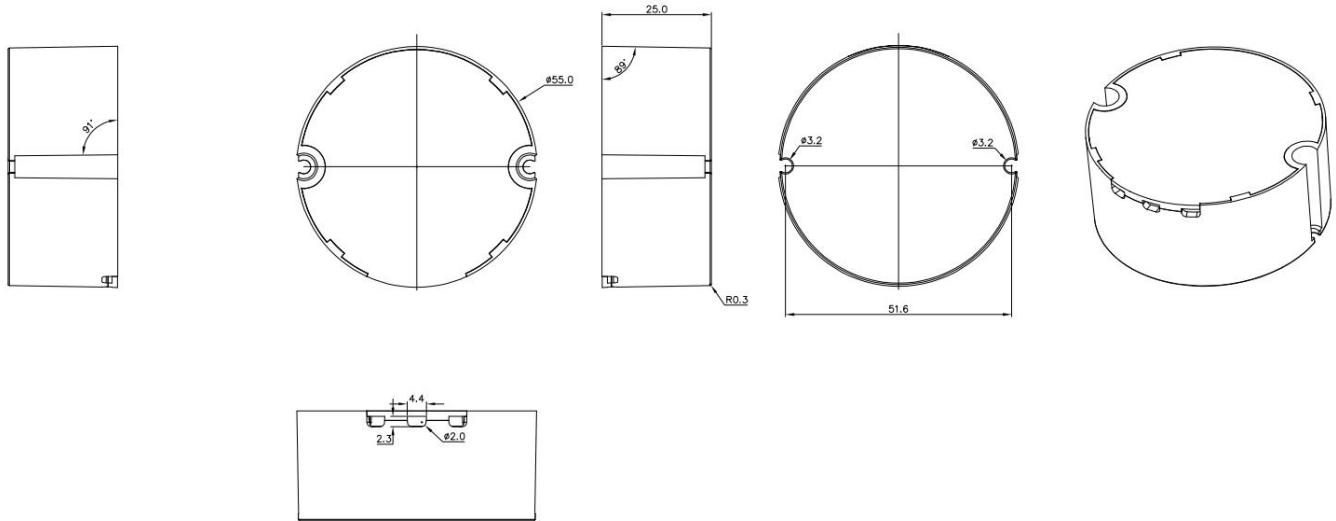

7. Wiring Diagram

Fig. A: Dali Dimming

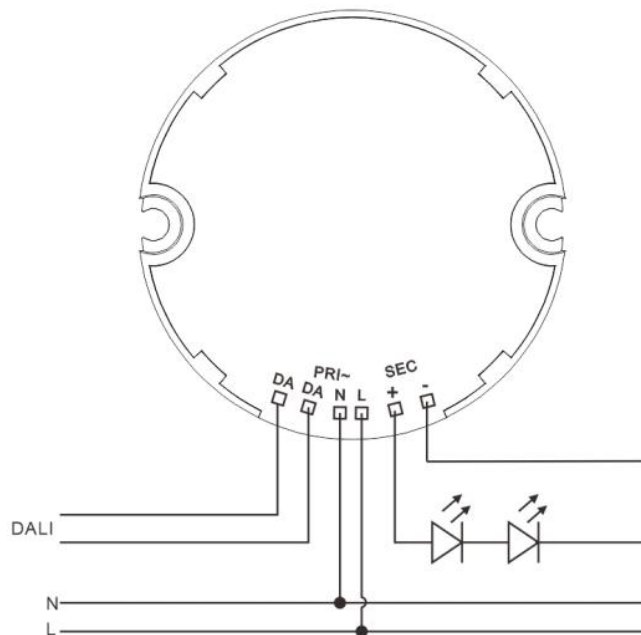
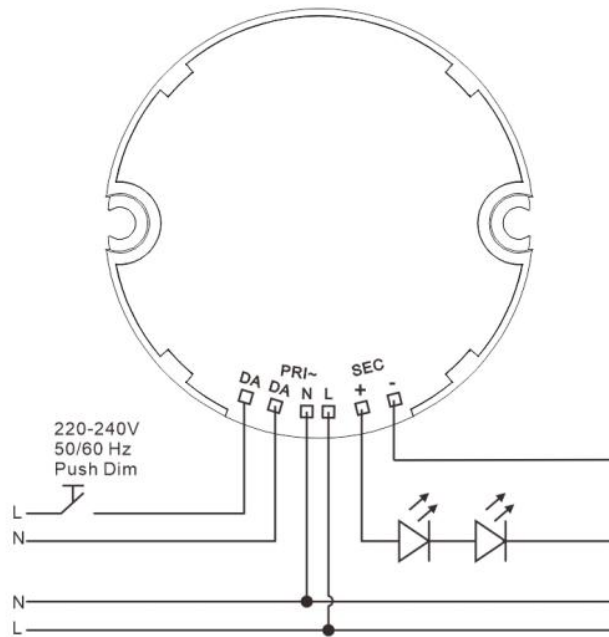

Fig. B: Push Dimming



Wiring type and cross section

Input: Brown-blue wire, 92mm, 0.5mm²

Output: Red-black wire, 100mm, 0.5mm²

Dali input: Yellow-white wire, 123mm, 0.5mm²

1. The factory default brightness is at 100%.
2. Up to 64 drivers can perform the PUSH dimming at the same time when utilizing one common push button
3. The maximum length of the cable from the push button to the last driver is 200 meters

8. Packing information

Packing way	Model	Carton L*W*H(mm)	Pcs/ Carton	Net weight/ Pcs(kg)	Net weight/ Carton(kg)	Gross weight/ Carton(kg)
industrial	RC18W300-700 DALI NFC	430*290*135	120	0.083	9.96	10.76

9. Wiring instructions

- All connections must be kept as short as possible to ensure good EMI behaviour
- Mains leads should be kept apart from LED Driver and other leads (ideally 5 – 10 cm distance)
- Advice the maximum length of output wires is 0.5 m
- Secondary switching is not permitted (Except for constant voltage)
- Incorrect wiring can damage LED modules.

- The wiring must be protected against short circuits to earth (sharp edged metals parts, metal cable clips, louver, etc.)
- Hot plug-in is not supported due to residual output voltage of > 0 V up to mains voltage. Danger to life.
- When connecting an LED load, restart the device to activate the LED output.
- This can be done via mains reset or via interface (DALI, DSI, switch DIM).

10. Replace LED module

- Mains off
- Remove LED module
- Wait for 30 seconds
- Connect LED module again
- Hot plug-in or secondary switching of LEDs is not permitted and may cause a very high current to the LEDs

11. Functions

11.1 OEM Identification

The OEM (Original Equipment Manufacturer) can set his own identification number.

DALI Part 251: Memory bank 1 extension.

11.2 OEM GTIN

The Original Equipment Manufacturer (OEM) can set his own Global Trade Item Number (GTIN).

DALI Part 251: Memory bank 1 extension.

11.3 Luminaire data

This function provides the asset management with accurate data about the luminaire.

DALI Part 251: Memory bank 1 extension.

DALI Part 253: Luminaire maintenance data.

11.4 LED current

The LED output current must be adapted to the connected LED module.

The value is limited by the current range of the respective device.

The output current of the LED driver can be adjusted in a certain range.

Adjustment is done by KGP Configurator via NFC.

More functions:

Action	Action duration	Function
Short push	<0.6s	Turn on/off
Short push five Times	<3s	Quit Corridor mode

Long push	0.6-3s	Dimming up or down
Long push	10s	Sync all LEDs to be 50% brightness, and the dimming rate is changed to 3S
Long push	20s	Dimming rate is changed to 6S
Long push	>2mins	Enter Corridor mode - LED keep 100% brightness for 2mins.

11.5 Switch DIM

Integrated Switch DIM function allows a direct connection of a push button for dimming and switching.

Brief push (< 0.6 s) switches LED driver ON and OFF. The dim level is saved at power-down and restored at power-up. When the push button is held, LED modules are dimmed. After repush the LED modules are dimmed in the opposite direction.

In installations with LED drivers with different dimming levels or opposite dimming directions (e.g. after a system extension), all LED drivers can be synchronized to 50 % dimming level by a 10 s push.

Use of push button with indicator lamp is not permitted.

11.6 Corridor FUNCTION

With the Corridor FUNCTION and a commercially available motion detector, it is easy to adapt the lighting in one area to its use.

That is, when the area is entered by a person, the lighting dims instantly to the desired brightness and is available in full strength.

After the area is left by the person, the brightness dims slowly to a smaller value or switches off completely.

The individual parameters of the desired profile, such as brightness values or delay times, can be adjusted flexibly and individually.

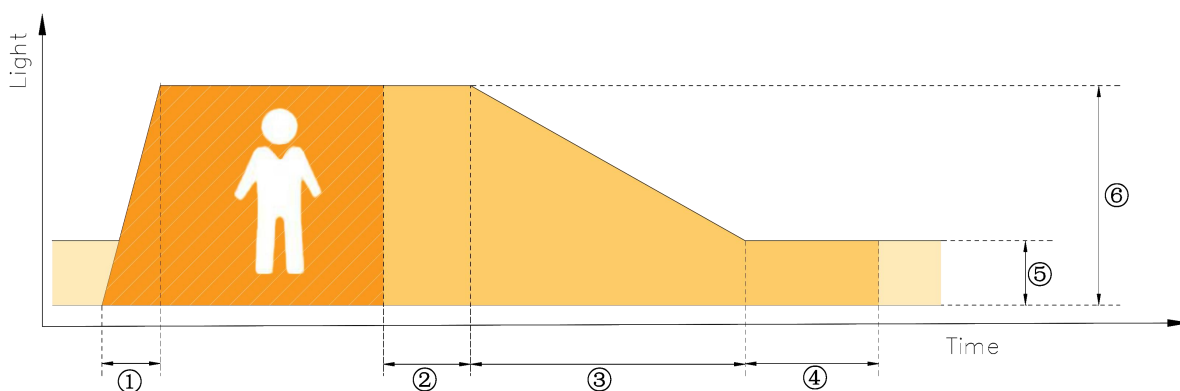

- ① Fade-in time(1s): the time that starts as soon as the presence of a person is detected. During the fade-in time the luminous intensity is faded up to the presence value.

- ② Run-on time(120s): the time that starts as soon as the presence of a person is no longer detected. If the presence of a person is detected again during the run-on time the run-on time is restarted from zero. If no presence is detected during the run-on time the fade time is started as soon as the run-on time expires.
- ③ Fade time(32s): the time during which the luminous intensity is faded from the presence value to the absence value.
- ④ Switch-off delay (Never Off): the time during which the absence value is held before the lighting is switched off. Depending on the profile selected the switch-off delay may have different values or may not be defined.
- ⑤ Absence value(default: 10 %): the luminous intensity when there is no person present.
- ⑥ Presence value (default: 100 %): the luminous intensity when persons are present.

11.7 Constant Light Output (CLO)

With this function the light output of the LED module can be kept equal over the lifetime.

The light output of an LED module reduces over the course of its lifetime.

The Constant Light Output (CLO) function compensates for this natural decline by constantly increasing the output current of the LED driver throughout its lifetime.

CLO shall be achieved by limitation of the LED current at the commissioning of the LED driver and providing a linear interpolation of the current over the time, depending on the data points given by the user.

The user has to insert up to eight pairs of data (time, level).

The output curve is the result of connecting the user data points linear.

Detailed description for CLO see product manual.

The minimal CLO starting point is limited by the smallest output current of the LED driver.

11.8 Dimming curve

DALI: The desired dimming behaviour is selected via two different dimming curves (logarithmic or linear).

The default setting of the dimming behaviour is logarithmic.

12. REVISION HISTORY

DATE	REV	Modification details
2025-04-11	V1.0	Initial release.
2025-10-22	V1.1	Update the maximum input current and label graph