

- 1. Customer's Spec. No. : ---
- 2. NDK Spec. No. : NSA3608A
- 3. Type : NZ2520SJ

4. Maximum Ratings

	Item	Ratings			Notes
		min	max	Units	
1	Supply Voltage	-0.3	4.0	V	
2	Input Voltage	-0.3	$V_{CC} + 0.3$	V	
3	Output Current	-20	+20	mA	
4	Storage Temperature Range	-55	+125	°C	

5. Electrical Specifications

(Unless otherwise noted, $T_A = -40$ to $+85$ °C, $V_{CC} = 1.8$ V, Load = 15 pF)

	Parameters	SYM	Electrical Spec.				Notes
			min	typ	max	Units	
1	Nominal Frequency	f_{nom}		12		MHz	
2	Supply Voltage	V_{CC}	1.62	1.8	1.98	V	
3	Current Consumption (Operating)	I_{CC}			0.6	mA	at 25 °C, No load
					1.14	mA	at 25 °C, 15 pF
4	Current Consumption (Stand-by)	I_{ST}			10	μA	at 25 °C
5	Output Level	-	C-MOS				
6	Load Capacitance	C_L			15	pF	
7	Operating Temperature Range	T_{opr}	-40		+85	°C	
8	Overall Frequency Tolerance	$\Delta f/f_{nom}$	-30		+30	ppm	*1
9	Output Voltage	V_{OL}			$0.1 V_{CC}$	V	
		V_{OH}	$0.9 V_{CC}$			V	
10	Rise Time(t_r), Fall Time(t_f)	t_r/t_f			8	ns	$0.1 V_{CC}$ to $0.9 V_{CC}$
11	Symmetry	SYM	45		55	%	at $1/2 V_{CC}$
12	Start-up Time	t_{su}			4	ms	
13	Output Wave Form	-	Square wave				
14	Stand-by Function	#1 PAD input			# 3 PAD output		
		H level ($0.7 V_{CC}$ to V_{CC}) or open			Operating		
		L level ($0.3 V_{CC}$ max)			High impedance		

*1 Inclusive of Freq. tolerance (at 25 °C), frequency/temperature characteristics, frequency/voltage coefficient.

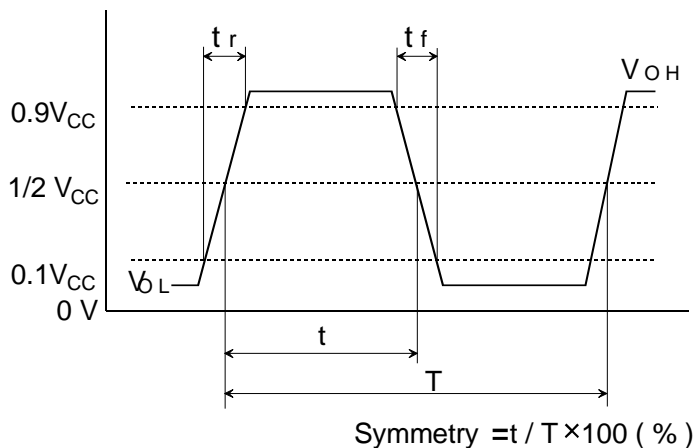

6. Measuring circuits

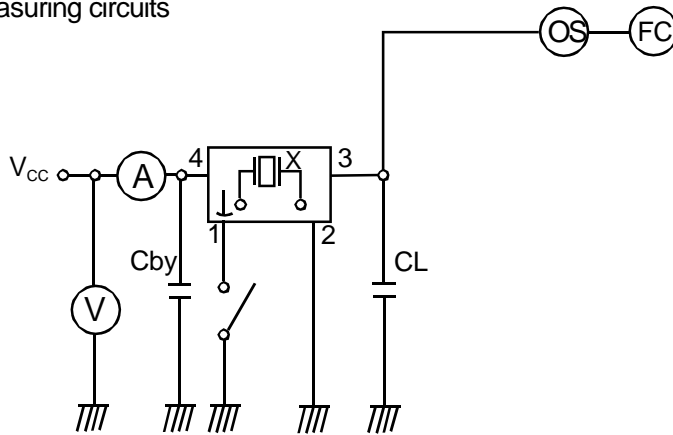

CL ; 15pF MAX including input capacity of oscilloscope

Cby ; Bypass capacitor (0.01uF)

7. Test data will not be submitted.

8. Application drawing

8.1 Dimension drawing

EKD14B-00027

8.2 Marking drawing

EKH11B-00052

8.3 Reliability assurance Item

EKS30B-00060

8.4 Taping & Reel drawing

EKK17B-00032

EEK17B-00015

9. Instruction Notice

9.1 Noise

When the NZ2520 series are used, the 0.01 μ F capacitor should be connected between V_{CC} and GND line. (Closer to the product terminal is desirable.)

9.2 Resistance to dropping

The NZ2520 series is designed to be impactproof so that no damage occurs when dropped a height(75 cm) three times. However, if dropped from a desk etc., it is advisable to check their performance or contact us to check it.

9.3 Electrostatic protection

The NZ2520 series employ C-MOS ICs for the active element. Please use them in static-free environments.

9.4 High temperature

Normal operation cannot be guaranteed for the NZ2520 series at +125 $^{\circ}$ C (for 24 hours). Be sure that the units are kept within the specified temperature range.

9.5 Cleaning

Basically, the NZ2520 series are applicable for ultrasonic wave cleaning. However, in some case, during ultrasonic wave cleanings, internal design may get damage. Please check condition carefully beforehand.

9.6 Other

The NZ2520 series are C-MOS applied products. And careful handling(same as with C-MOS IC) are needed to avoid electrostatic problems.

Incorrect PAD connection is cause of trouble. Please make sure to connect correctly as below.

#2 terminal \rightarrow GND

#4 terminal \rightarrow V_{CC}

10. Notes On Use

- 10.1 Even if the appearance color etc. of the product differs by purchasing the component parts by more than two companies, there is no influence on the characteristics and reliability.
- 10.2 IN THE CASE OF THE FOLLOWING ITEMS, WE ARE NOT RESPONSIBLE FOR WARRANTY / COMPENSATION.
- (1) WHEN PRODUCTS OF THIS SPECIFICATION ARE USED FOR EQUIPMENT RELATED TO HUMAN LIFE OR PROPERTY, IT IS THE RESPONSIBILITY OF THE CUSTOMER TO CONFIRM THE INFLUENCE ON THIS PRODUCT AND EQUIPMENT TO BE USED BEFOREHAND, CONDUCT NECESSARY SAFETY DESIGN (INCLUDING REDUNDANT DESIGN, MALFUNCTION PREVENTION DESIGN, etc.), PLEASE USE IT AFTER SECURING SUFFICIENT SAFETY OF EQUIPMENT.
1. SAFETY-RELATED EQUIPMENT SUCH AS AUTOMOBILES, TRAINS, SHIPS, etc., OR EQUIPMENT DIRECTLY INVOLVED IN OPERATION
 2. AIRCRAFT EQUIPMENT
 3. SPACE EQUIPMENT
 4. MEDICAL EQUIPMENT
 5. MILITARY EQUIPMENT
 6. DISASTER PREVENTION / CRIME PREVENTION EQUIPMENT
 7. TRAFFIC LIGHT
 8. OTHER EQUIPMENT REQUIRING THE SAME PERFORMANCE AS THE ABOVE-MENTIONED EQUIPMENT
- (2) IN CASES WHERE IT IS NOT INDICATED IN THE REQUESTED STANDARD AND IS USED UNDER CONDITIONS OF USE (INCLUDING CIRCUIT MARGIN etc.) THAT CAN NOT BE PREDICTED AT THE PRODUCTION STAGE.
- (3) WHEN USING ULTRASONIC WELDING MACHINE. (THERE IS A POSSIBILITY THAT THE CHARACTERISTIC DEGRADATION IS CAUSED BY THE RESONANCE PHENOMENON OF THE PIEZOELECTRIC MATERIAL. (EXAMPLE; CRYSTAL PIECE))
WE WILL NOT TAKE ANY RESPONSIBILITY FOR THE INFLUENCE OF THE CUSTOMERS' PROCESS.
SO, PLEASE SUFFICIENTLY EVALUATE AT A SAMPLE STEP WHEN YOU USE ULTRASONIC WELDING MACHINE.
- (4) USING RESIN MOLD MAY AFFECT THE PRODUCT CHARACTERISTIC.
PLEASE MAKE SURE TO TELL OUR SALES CONTACT WHEN YOU USE RESIN MOLD. WE WILL PERFORM INDIVIDUAL CORRESPONDENCE ABOUT A DELIVERY SPECIFICATION AND A EVALUATION METHOD.
IN ADDITION, IF YOU USE RESIN MOLD WITHOUT CONTACTING US, AND CAUSES DAMAGES AGAINST A CUSTOMER OR A THIRD PARTY, WE WILL NOT BE LIABLE FOR THE DAMAGES AND OTHER RESPONSIBILITIES BECAUSE WE CONSIDER IT IS UNDER SELF-RESPONSIBILITY USING RESIN MOLD.
WE WILL NOT TAKE ANY RESPONSIBILITY FOR THE INFLUENCE OF THE CUSTOMERS' PROCESS. PLEASE EFFICIENTLY EVALUATE AT A SAMPLE STEP WHEN YOU USE RESIN MOLD.
- (5) WHEN PERFORMING IMPROPER HANDLING THAT EXCEEDS THE GUARANTEED RANGE.
- 10.3 This product can not be used for equipment related to the safety of automobiles or equipment directly involved in operation. (example: air bag, TPMS, engine control, steering control, brake control etc.)

11. Notes on storage

- 11.1 When storing the product in high temperature and high humidity condition for a long time, product characteristics (solderability etc.) and packaging condition may be deteriorated. Please store product at temperature + 5 °C ~ + 35 °C, humidity 85 % RH or less. The product is an electronic component, so please do not storage and use, under a dewing state.
- 11.2 The product storage deadline is 12 months after delivery in unopened state. Please use within storage deadline. If you exceed storage deadline, please check the product characteristics etc, please use.

12. Other Requests

- 12.1 Please use this specification only for confirmation of the specification of this product.
- 12.2 If there is a change request, please contact within three weeks from issue date. If there is no communication, we will deliver the product under the contents of this specification. In addition, if the product delivery date is within 3 weeks and there is a change request, we will consult the processing separately.

12.3 NOTES THAT ARE DESCRIBED IN THIS DOCUMENT, IF YOU DID NOT COMPLY WITH THE PROHIBITIONS, AND OTHER PLEASE, INCLUDING THE FAILURE CORRESPONDENCE OR COMPENSATION OR DAMAGES, WE CAN NOT ASSUME THE RESPONSIBILITY, PLEASE UNDERSTAND.

13. Prohibited items

Be sure to use the product under the following conditions. Otherwise, the characteristics deterioration or destruction of the product may result.

(1)Reflow soldering heat resistance

Peak temperature: 265 °C, 10 sec

Heating: 230 °C or higher, 40 sec

Preheating: 150 °C to 180 °C, 120 sec

Reflow passage times: 3 times

(2)Manual soldering heat resistance

Pressing a soldering iron of 350 °C on the terminal electrode for 3 sec.

*Example For Soldering Conditions (The below graph corresponds to Pb free solder)

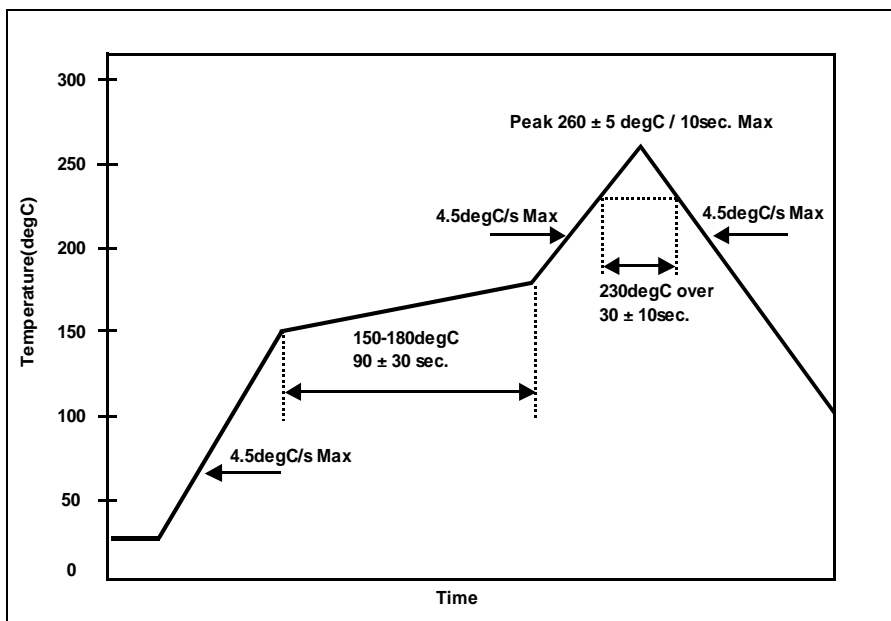

* Recommended footprint

[mm]

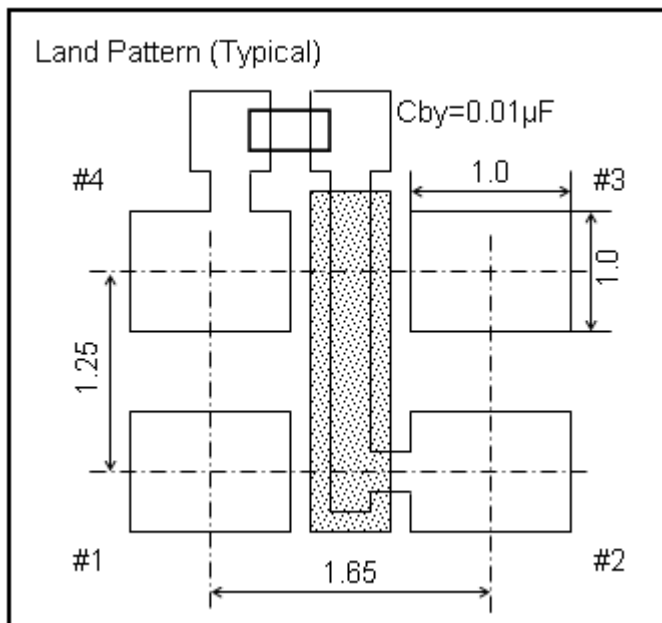

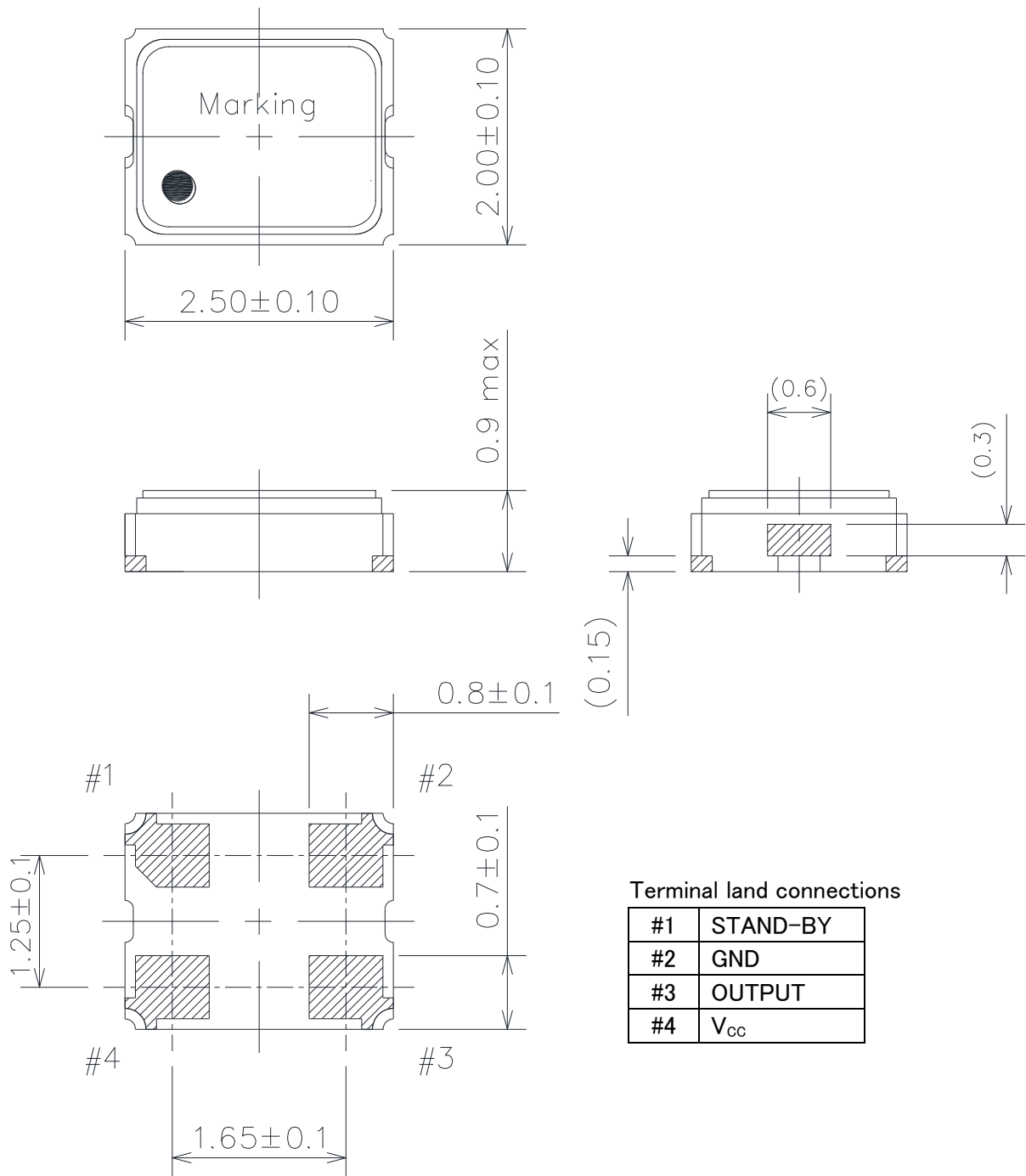

Date of Revise	Charge	Approved	Reason	
E 20.Sep.2018	H.Okajima	Y.Akasaka	Add size of corner castellation	
Date	Name	Third Angle Projection	Tolerance	
Drawn 23.Oct.2003	M.Yamaguchi	Dimension : mm	-----	
Designed 27.Jun.2003	M.Yamaguchi	Title NZ2520S Dimension of External	Drawing No. EKD14B-00027	
Checked -----	-----			Rev. E
Approved 23.Oct.2003	H.Omata			

NIHON DEMPA KOGYO CO., LTD.

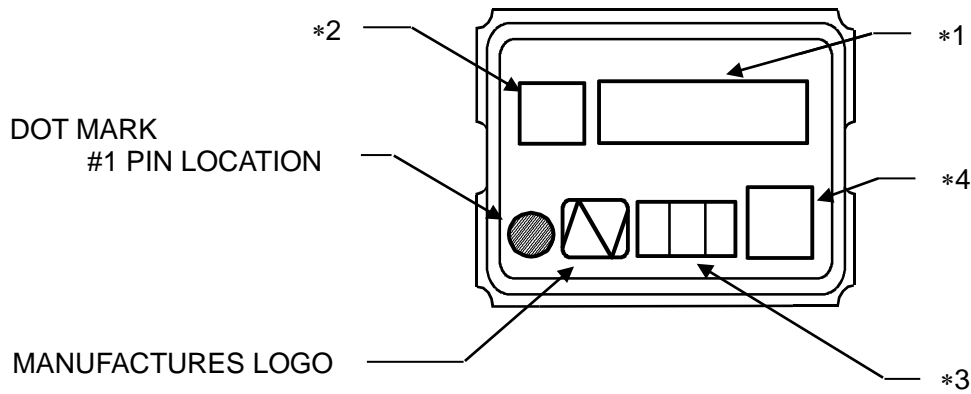

***1 [FREQUENCY]**

Digits are five and 6TH digit will be omitted.
 MHz unit sign is not marked.
 ex,) 28.63636MHz → 28.636 [Unit sign not marked]

***2 [MODEL MARK]**

A last digit of model is marked. →

[MODEL MARK]	
NZ2520SA	→ Space
NZ2520SB	→ B
NZ2520SC	→ C
NZ2520SD	→ D
NZ2520SDA	→ D
NZ2520SEA	→ E
NZ2520SEB	→ E
NZ2520SF	→ F
NZ2520SG	→ G
NZ2520SH	→ H
NZ2520SHA	→ H
NZ2520SHB	→ H
NZ2520SHC	→ H
NZ2520SJ	→ J

***3 [WEEK CODE (Digit are three)]**

ex1,) In case of 7TH week of 2006

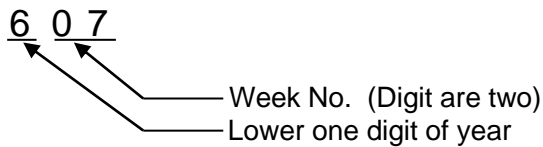

ex2,) In case of 31TH week of 2006

6 3 1

***4 [Trace code]**

Trace code consists of four digits number or letter.
 This code indicates production date and production line number.

Date of Revise	Charge	Approved	Reason		
K	12.Apr.2018	Y.Okajima	S.Murase	Model mark addition.(NZ2520SHB,SHC)	
Drawn	Date	Name	Third Angle Projection	Tolerance	Scale
Y.Oishi	27.Jan.2006	Y.Oishi	mm	-----	-----
Designed	Date	Name	Title	Drawing No.	Rev.
Y.Okajima	27.Jan.2006	C.Ishimaru			
C.Ishimaru	27.Jan.2006	H.Omata			
Approved			NZ2520S Marking	EKH11B-00052	K

Environmental Test Conditions	Specification
1. Thermal Shock Test 1 cycle: -40°C (30 minutes) ~ +85°C(30 minutes) Number of cycle: 100 cycle.	*1
2. High Temperature High Humidity Test Temperature : +85°C, Humidity : 80 ~ 85%, Time : 250 hours.	*1
3. +85°C Aging (Non Operating) Temperature : +85°C, Time : 500 Hours.	*1
4. Vibration Test MIL-STD-202F test method: 204D Test condition : D 10 ~ 2000Hz, 1.52mmp-p, or 196m/s ² 20 minutes/cycle, XYZ 3 directions 4 times.	*1
5. Shock Test MIL-STD-202F test method : 213B Test condition : Half sinusoidal wave 29400m/s ² , 0.3ms, 3 directions, 3 times each.	*1
6. Drop Test (JIG attachment) Dummy load : 200g, Height : 1.5m, Fall conditions : On concrete The number of times of fall : Six directions and 1 time each are made into 1 cycle, and it is 10 cycle.	*1
7. Soldering Test (Reflow) Pre heat : 150±10°C, 60~120sec. Main heat : 30±1 seconds after amounting to 215 °C. Peak temperature : 240°C	More than 90% of should be covered by solder.
8. Soldering Resistance (Reflow) Pre heat : 180±10°C, 120 sec min, Main heat : 225°C min, 70sec max. Peak temperature : 260°C . Reflow time : 3 times.	*1
<p>*1 After the test mentioned above, the electrical specifications are satisfied. Also frequency deviation before and after test should be</p> <p style="text-align: center;">$\Delta F/F \pm 10 \times 10^{-6}$</p> <p>The electrical specifications are I_{CC}, T_r/T_f, V_{OL}/V_{OH}, duty cycle, stand-by current consumption.</p>	

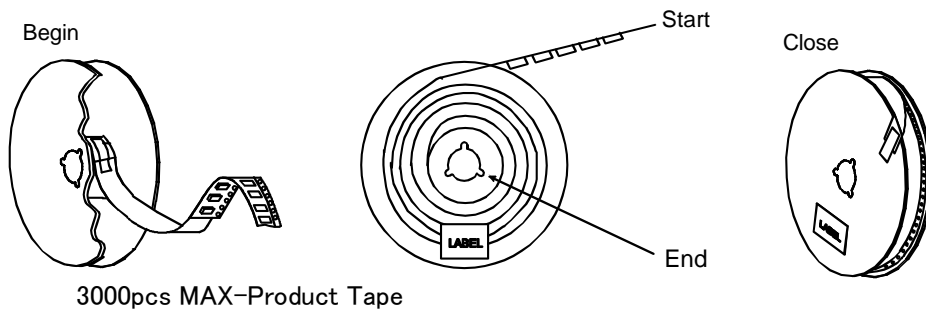
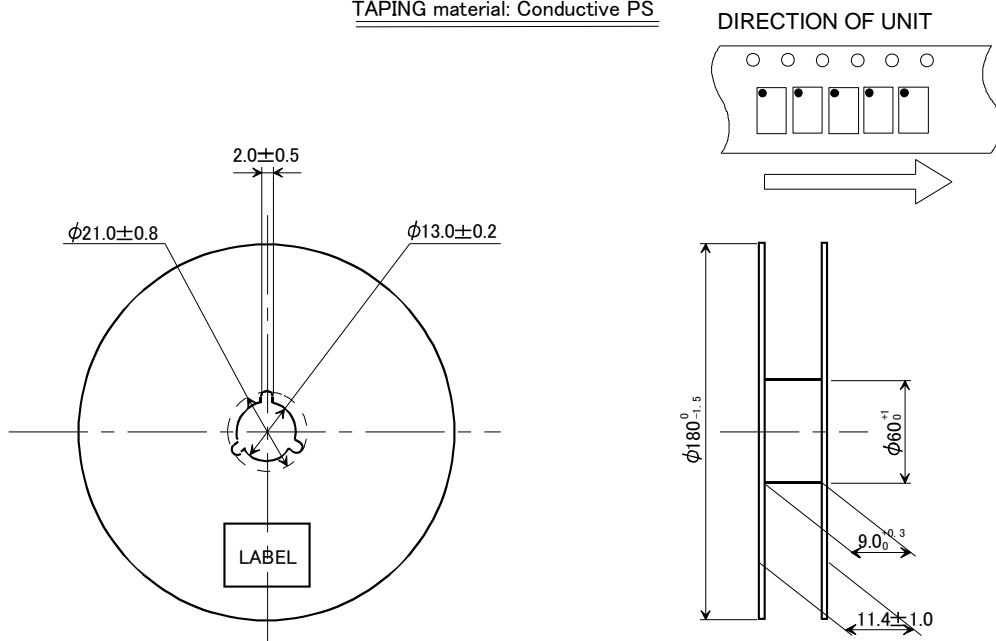
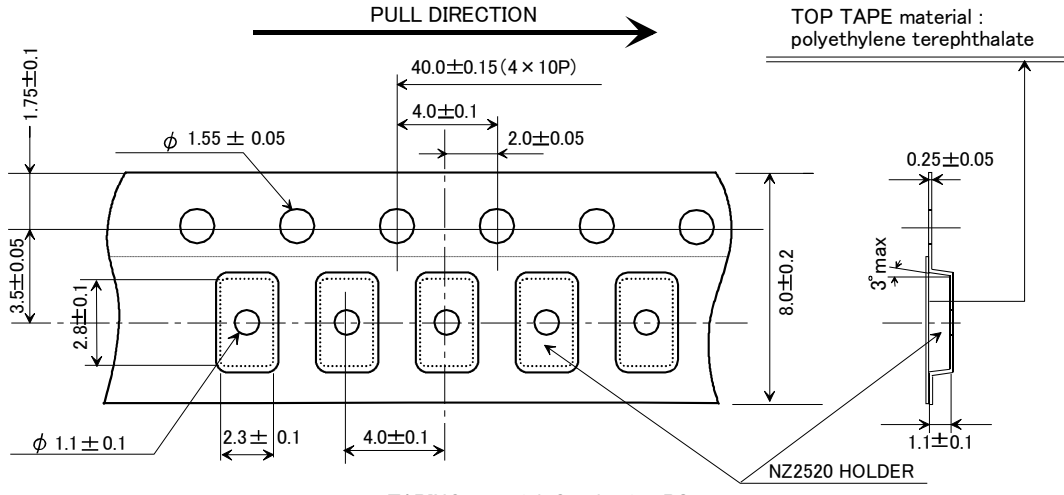

	Date of Revise	Charge	Approved	Reason		
C	5.Sep.2012	Y.Oishi	C.Ishimaru	3000pcs-Product Tape→3000pcs MAX-Product Tape.		
	Date	Name	Third Angle Projection	Tolerance		
Drawn	7.Oct.2003	Y.Okajima	Dimension:mm	Scale		
Designed	7.Oct.2003	Y.Okajima	Title	Drawing No.		
Checked					NZ2520	EKK17B-00032
Approved	7.Oct.2003	H.Omata				
				C		

NIHON DEMPA KOGYO CO., LTD.

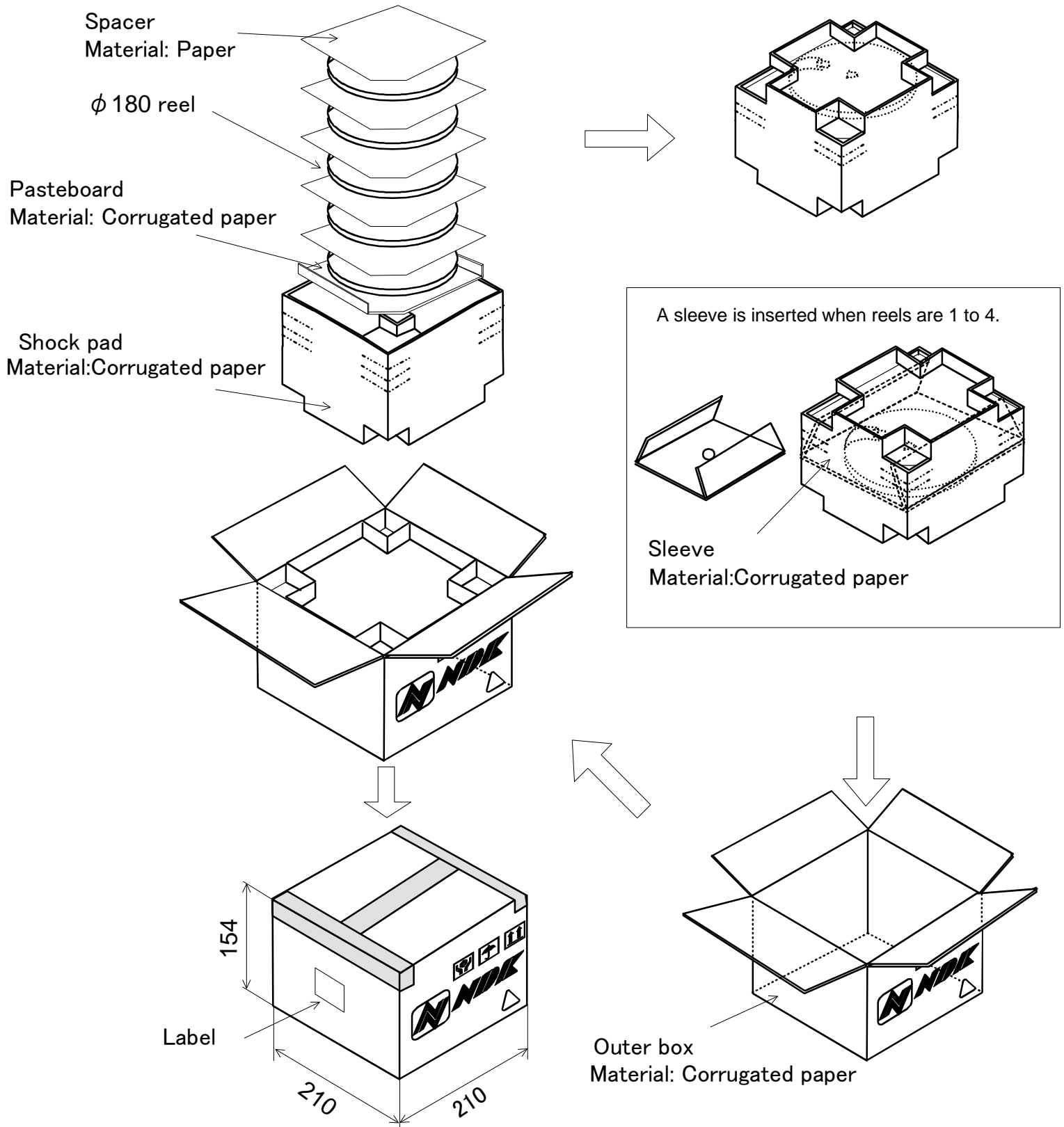

	Date of Revise	Charge	Approved	Reason	
C	4 Jul. 2012	H. Ohkubo	K. Oguri	Addition of condition when reels are 1 to 4.	
	Date	Name	Third Angle Projection	Tolerance	Scale
Drawn	26 Feb. 2010	H. Ohkubo	Dimension:mm	-----	-----
Designed	26 Feb. 2010	K. Oguri	Title 180 dia. Reel package	Drawing No. EEK17B-00015	Rev.
Checked	26 Feb. 2010	K. Oguri			C
Approved	26 Feb. 2010	J. Nakamura			

NIHON DEMPA KOGYO CO., LTD.