



RoHS Compliant
Directive 2011/65/EU

SPECIFICATION

Customer: ELTECH

Item:	Simple Packaged Crystal Oscillator (SPXO)
Type:	NZ2016SHB
Nominal Frequency:	32.768 kHz
Customer's Spec. No.:	---
NDK Spec. No.:	END5385A

Receipt

Revision Record						
Rev.	Date	Items	Contents	Approved	Checked	Drawn
----	28.Apr.2017	Issue	---	S.Murase	M.Kashiwamura	Y.Ichikawa

- 1. Customer's Spec. No. : ---
- 2. NDK Spec. No. : END5385A
- 3. Type : NZ2016SHB

4. Maximum Ratings

	Item	Ratings			Notes
		min	max	Units	
1	Supply Voltage	-0.3	+4.5	V	
2	Storage Temperature Range	-55	+125	°C	

5. Electrical Specifications

(Unless otherwise noted, TA=-40 to +85 °C, V_{CC}=3.0 V, Load=15 pF)

	Parameters	SYM	Electrical Spec.				Notes
			min	typ	max	Units	
1	Nominal Frequency	f _{nom}		32.768		kHz	
2	Supply Voltage	V _{CC}	2.7	3.0	3.3	V	
3	Current Consumption (Operating)	I _{CC}			32	μA	at 25 °C
4	Current Consumption (Stand-by)	I _{ST}			5	μA	at 25 °C
5	Output Level	-	CMOS				
6	Load Capacitance	C _L			15	pF	
7	Operating Temperature Range	T _{opr}	-40		+85	°C	
8	Overall Frequency Tolerance	Δf/f _{nom}	-50		+50	ppm	*1
9	Long-term frequency stability	Δf _{lt}	-5		+5	ppm	at 25 °C, 1year
10	Output Voltage	V _{OL}			0.1 V _{CC}	V	
		V _{OH}	0.9 V _{CC}			V	
11	Rise Time(t _r), Fall Time(t _f)	t _r /t _f			50	ns	0.1 V _{CC} to 0.9 V _{CC}
12	Symmetry	SYM	45		55	%	at 1/2 V _{CC}
13	Start-up Time	T _{su}			3	ms	
14	Output Wave Form	-	Rectangular				
15	Stand-by Function	#1 PAD input				# 3 PAD output	
		H level (0.7 V _{CC} to V _{CC}) or open				Operating	
		L level (0.3 V _{CC} max)				High impedance	

*1 Inclusive of Freq. tolerance (at 25 °C), frequency/temperature characteristics, frequency/voltage coefficient.

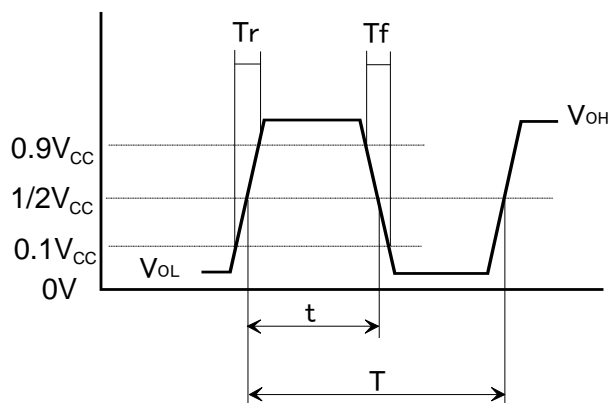

Symmetry = $t/T \times 100\%$

6. Measuring circuits

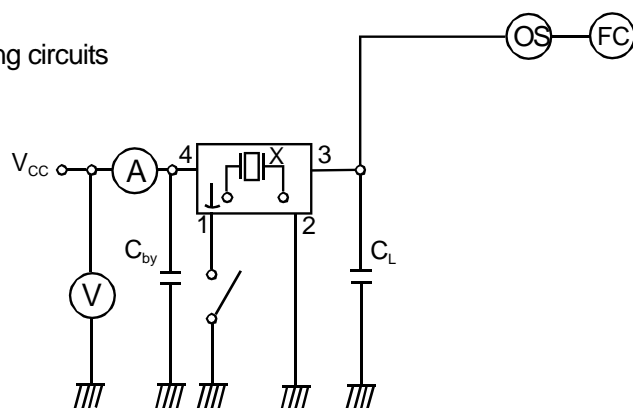

C_L ; 15pF MAX including input capacity of oscilloscope

C_{by} ; Bypass capacitor (0.01uF)

7. Test data will not be submitted

8. Application drawing

8.1 Dimension drawing

EKD14B-00093

8.2 Marking drawing

EKH11B-00141

8.3 Reliability assurance Item

EKS30B-00092

8.4 Taping & Reel drawing

EKK17B-00076

EEK17B-00015

9. Instruction Notice

9.1 Noise

When the NZ2016S series are used, the 0.01 μ F capacitor should be connected between V_{CC} and GND line. (Closer to the product terminal is desirable.)

9.2 Resistance to dropping

The NZ2016S series is designed to be impactproof so that no damage occurs when dropped a height (75 cm) three times. However, if dropped from a desk etc., it is advisable to check their performance or contact us to check it.

9.3 Electrostatic protection

The NZ2016S series employ C-MOS ICs for the active element. Please use them in static-free environments.

9.4 High temperature

Normal operation cannot be guaranteed for the NZ2016S series at +125°C(for 24 hours). Be sure that the units are kept within the specified temperature range.

9.5 Cleaning

Basically, the NZ2016S series are applicable for ultrasonic wave cleaning. However, in some case, during ultrasonic wave cleanings, internal design may get damage. Please check condition carefully beforehand.

9.6 Other

The NZ2016S series are C-MOS applied products. And careful handling (same as with C-MOS IC) are needed to avoid electrostatic problems.

Incorrect PAD connection is cause of trouble. Please make sure to connect correctly as below.

#2 terminal \rightarrow GND

#4 terminal \rightarrow V_{CC}

10. Notice

- 10.1 Order items are manufactured according to specification. As to conditions, which are not indicated in this specification and unpredictable such as applied condition and oscillation margin, please check them beforehand.
- 10.2 Unless we receive request for modification within 3 weeks from the issue date of this NDK specification sheet, we will supply products according to this specification. Also, if you'd like to modify specification of order, which has been placed with delivery request within 3 weeks from the issue data of this specification sheet, we would like to discuss with you separately.
- 10.3 In no event shall the company be liable for any product failure resulting from an inappropriate handling or operation of the product beyond the scope of its guarantee.
- 10.4 Where any change to the process condition is made due to the change(s) in the production line, inform personnel of the specifications.
- 10.5 Should this specification data give rise to any disputes relating to any intellectual property rights or any other rights of a third person, the company shall not indemnify anyone for any damage. Their disclosure must not be construed as the grant of a license to use any of the intellectual property rights owned by the company.
- 10.6 If you intend to use products listed on this specification for applications that may result in loss of life or assets (controls relating to safety, medical equipment, aeronautical equipment, space equipment, etc.), please do not fail to advise us of your intention beforehand.
- 10.7 In the company's production process whatever amount of ozone depleting substances (ODS) as specified in the Montreal protocol is not used.
- 10.8 Information contained in this specification must not be quoted, reproduced or used for other purposes including processing either in part or in full without obtaining prior approval from the company.
- 10.9 The appearance color and so on have a different case by purchasing it more than 2 suppliers of the component, but characteristic and reliability are guaranteed.
- 10.10 In case of the product long time keep at high temperature and humidity, may affect product characteristic (solder ability) and a packing condition.
Please keep at storage condition of temperature +5 °C ~+35 °C, humidity ~85 %RH.

11. Prohibited items

Be sure to use the product under the following conditions. Otherwise, the characteristics deterioration or destruction of the product may result.

(1) Reflow soldering heat resistance

Peak temperature: 265 °C, 10 sec

Heating: 230 °C or higher, 40 sec

Preheating: 150 °C to 180 °C, 120 sec

Reflow passage times: 3 times

(2) Manual soldering heat resistance

Pressing a soldering iron of 350 °C on the terminal electrode for 3 sec.

Example For Soldering Conditions (The below graph corresponds to Pb free solder)

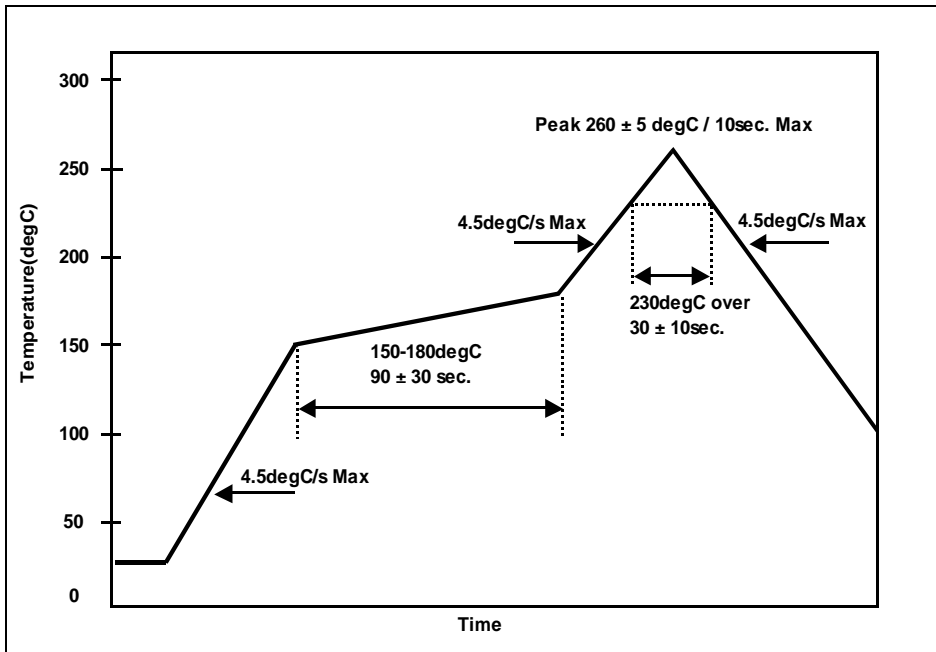

*Recommended footprint

[mm]

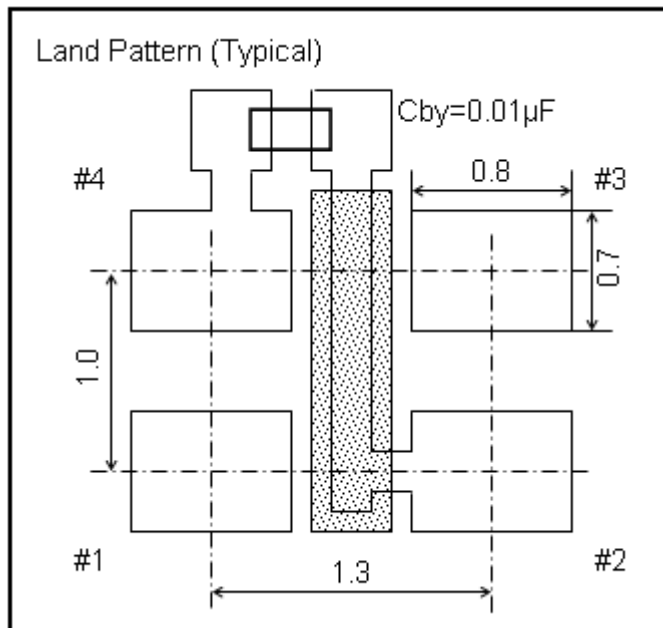

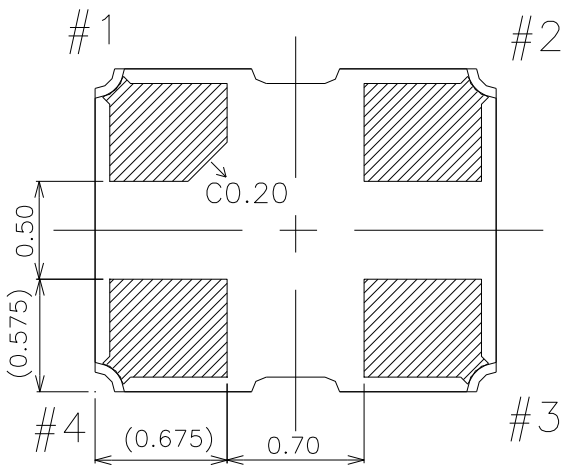
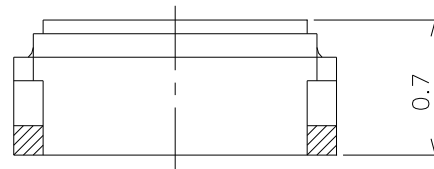
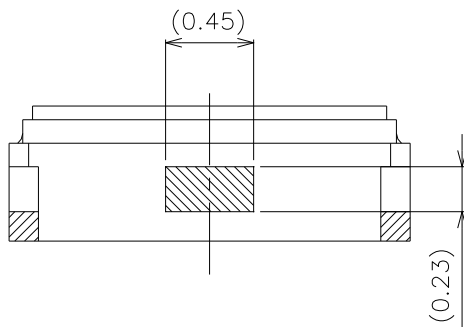
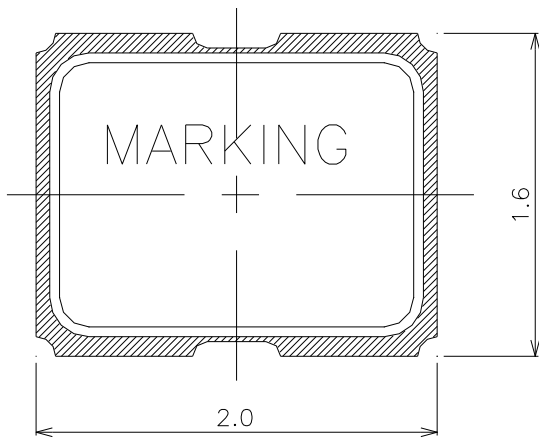

Terminal land connections

#1	STAND-BY
#2	GND
#3	OUTPUT
#4	Vcc

Unit:mm

Date of Revise	Charge	Approved	Reason		
-	-	-	-		
Date	Name	Third Angle Projection	Tolerance	Scale	
Drawn 8.Mar.2016	M.Mizoguchi	Dimension:mm	±0.1	-----	
Designed 8.Mar.2016	M.Mizoguchi	Title NZ2016S Dimension of External	Drawing No. EKD14B-00093	Rev.	
Checked 8.Mar.2016	T.Abe			-	
Approved 8.Mar.2016	S.Murase			-	

NIHON DEMPA KOGYO CO., LTD.

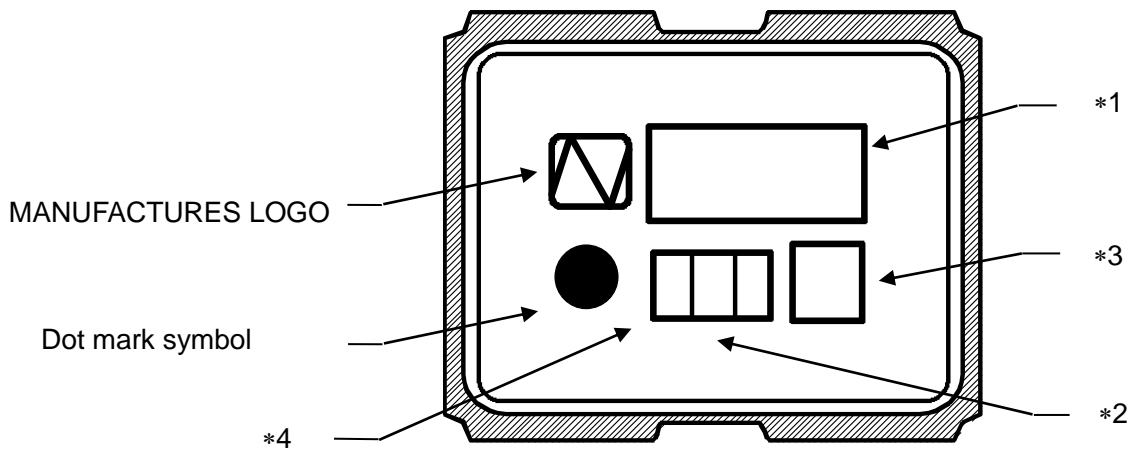

***1 [FREQUENCY]**

Digits are two and 3rd digit will be omitted.
 kHz unit sign is marked.
 ex,) 32.768kHz → 32K

***2[Lot Code(Digits are Two)]**

a:First digit:lower one digit of year.
 ex) 2016 → 6

b:Second digit:Month No.(See table)

Month	Jan	Feb	Mar	Apr	May	Jun	Jul	Aug	Sep	Oct	Nov	Dec
Month No.	1	2	3	4	5	6	7	8	9	X	Y	Z

***3 [Trace code]**

Trace code consists of four digits number or letter.
 This code indicates production date and production line number.

***4 [Model Symbol]**
 See right table.

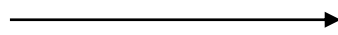

[MODEL MARK]	
NZ2016SG	→ G
NZ2016SH	→ H
NZ2016SHB	→ H

Date of Revise	Charge	Approved	Reason	
A	28.Apr.2017	Y.Ichikawa	S.Murase	*4: NZ2016SHB are additions.
Date	Name	Third Angle Projection	Tolerance	Scale
Drawn	19.Aug.2016	M.Mizoguchi	mm	-----
Designed	19.Aug.2016	M.Mizoguchi	Title	Drawing No.
Checked	19.Aug.2016	-----		
Approved	19.Aug.2016	Y.Akasaka		
			NZ2016S(kHz) Marking	EKH11B-00141
				Rev.
				A

Environmental Test Conditions	Specification
1. Pre- and Post-Stress Electrical Test Refer to AEC-Q200-REV.D TABLE.11 NO.1	*1
2. High Temperature Exposure (Storage) Refer to AEC-Q200-REV.D TABLE.11 NO.3	*3
3. Temperature Cycling Refer to AEC-Q200-REV.D TABLE.11 NO.4	*3
4. Biased Humidity Refer to AEC-Q200-REV.D TABLE.11 NO.7	*2
5. Operational Life Refer to AEC-Q200-REV.D TABLE.11 NO.8	*3
6. External Visual Refer to AEC-Q200-REV.D TABLE.11 NO.9	*4
7. Physical Dimension Refer to AEC-Q200-REV.D TABLE.11 NO.10	*5
8. Resistance to Solvents Refer to AEC-Q200-REV.D TABLE.11 NO.12	*2, *4
9. Mechanical Shock Refer to AEC-Q200-REV.D TABLE.11 NO.13	*2
10. Vibration Refer to AEC-Q200-REV.D TABLE.11 NO.14	*2
11. Resistance to Soldering Heat Refer to AEC-Q200-REV.D TABLE.11 NO.15	*2
12. Solderability Refer to AEC-Q200-REV.D TABLE.11 NO.18	*6
13. Electrical Characterization Refer to AEC-Q200-REV.D TABLE.11 NO.19	*2
14. Board Flex Refer to AEC-Q200-REV.D TABLE.11 NO.21	*7
15. Terminal Strength Refer to AEC-Q200-REV.D TABLE.11 NO.22	*7
<p>*1 After the test mentioned above, the electrical specifications are satisfied.</p> <p>*2 Frequency deviation before and after test should be $\Delta F/F \leq \pm 10 \times 10^{-6}$, Current consumption deviation before and after test should be $\Delta I/I \leq \pm 10\%$.</p> <p>*3 Frequency deviation before and after test should be $\Delta F/F \leq \pm 30 \times 10^{-6}$, Current consumption deviation before and after test should be $\Delta I/I \leq \pm 10\%$.</p> <p>*4 Inspect device construction, marking, and workmanship.</p> <p>*5 External is satisfied.</p> <p>*6 95% min. covered by new solder.</p> <p>*7 Visual inspection to confirm no cracking of materials and no break of sealing.</p> <p>The electrical specifications are I_{CC}, Tr/Tf, V_{OL}/V_{OH}, duty cycle, stand-by current consumption.</p>	

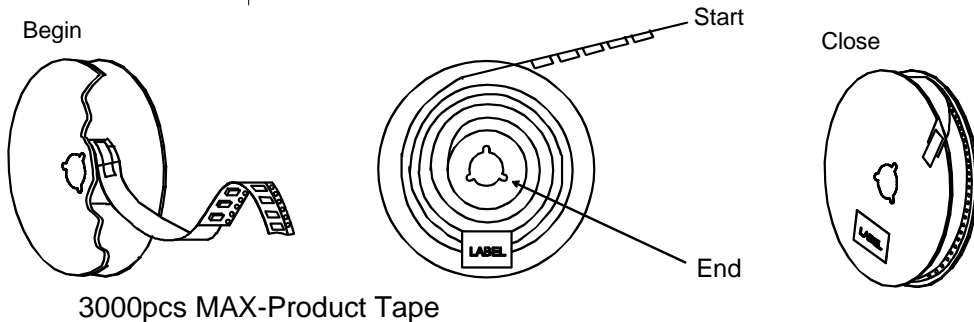
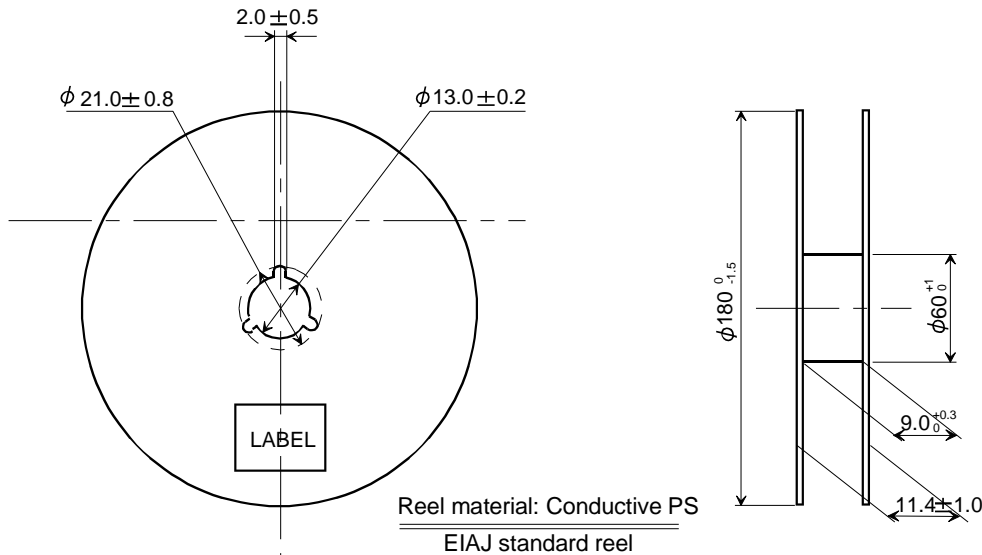
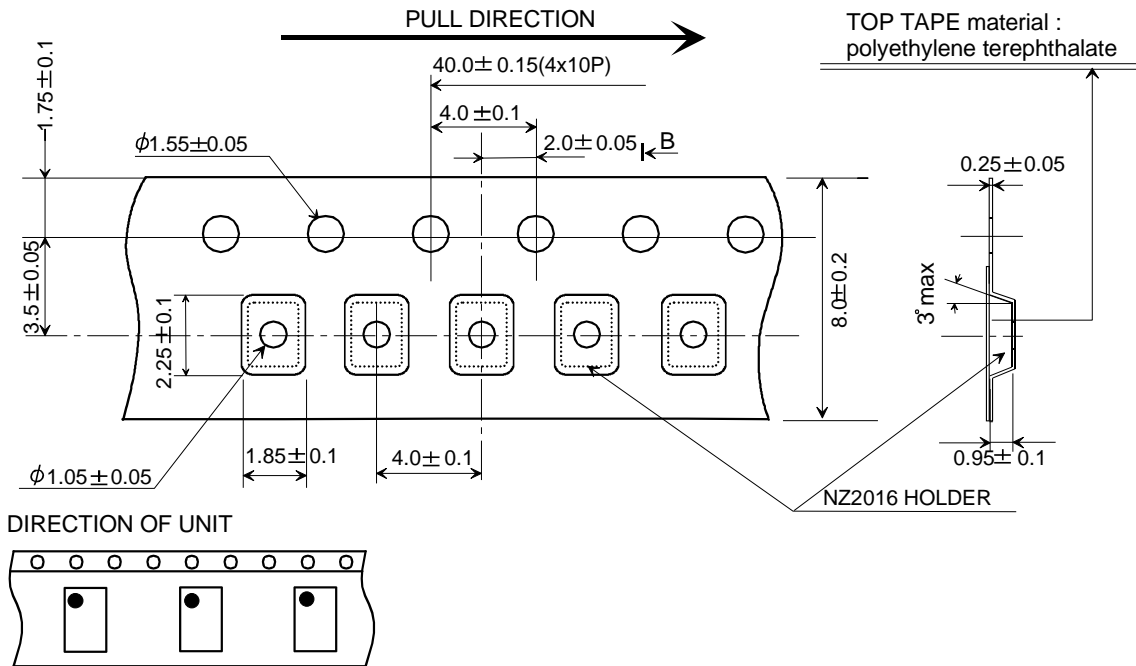

	Date of Revise	Charge	Approved	Reason
B	7.Dec.2015	C.Sakurai	Y.Akasaka	Title of change(NZ2016SA→NZ2016)
	Date	Name	Third Angle Projection	Tolerance
Drawn	18.Jan.2008	S.Murase	Dimension:mm	Scale
Designed	18.Jan.2008	S.Murase	Title	Drawing No.
Checked	-----	-----		
Approved	18.Jan.2008	Y.Nomura		
			NZ2016 Taping and Reel Spec.	EKK17B-00076
				Rev. B

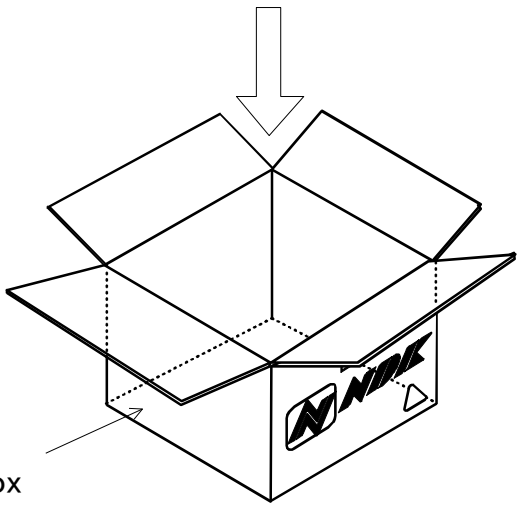
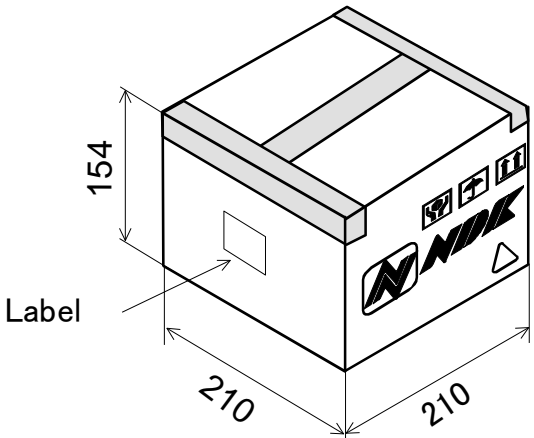
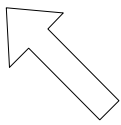
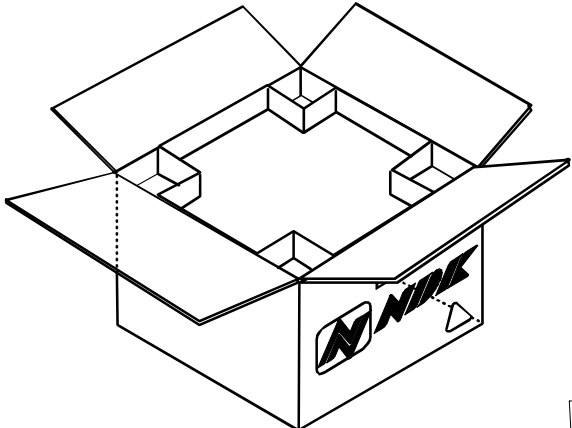
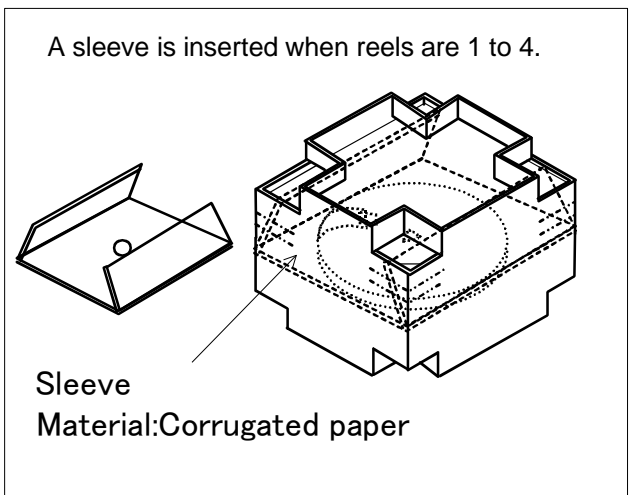
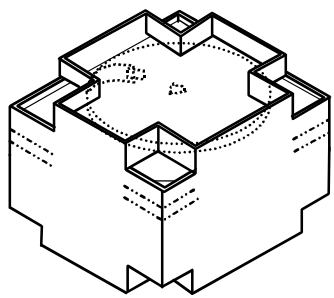
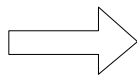
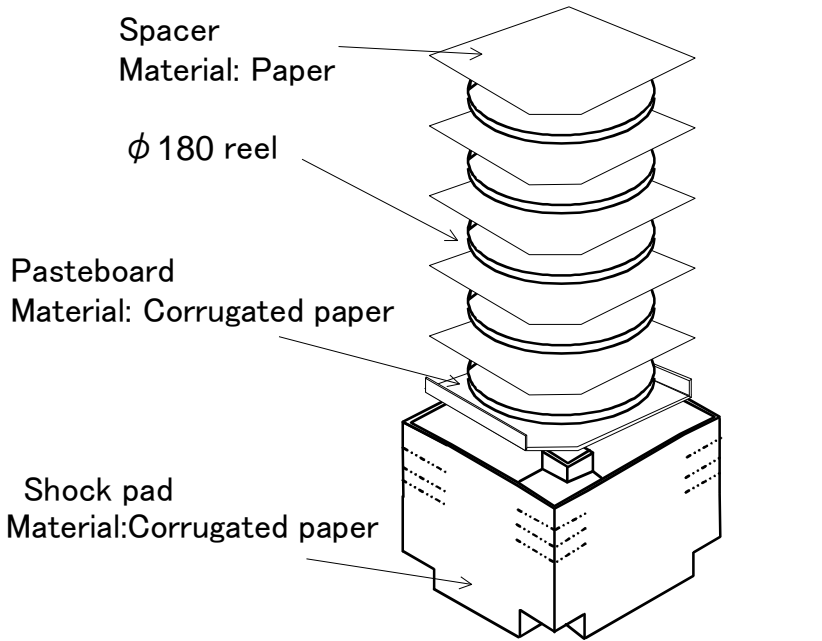

	Date of Revise	Charge	Approved	Reason
C	4 Jul. 2012	H. Ohkubo	K. Oguri	Addition of condition when reels are 1 to 4.
	Date	Name	Third Angle Projection	Tolerance
Drawn	26 Feb. 2010	H. Ohkubo	Dimension:mm	-----
Designed	26 Feb. 2010	K. Oguri	Title	Drawing No.
Checked	26 Feb. 2010	K. Oguri	180 dia. Reel package	EEK17B-00015
Approved	26 Feb. 2010	J. Nakamura		
				C

NIHON DEMPA KOGYO CO., LTD.