

RoHS Compliant
Directive 2011/65/EU

SPECIFICATION

Customer: ELTECH SPB

Item:	Crystal Clock Oscillators
Type:	NZ2520SD
Nominal Frequency:	25MHz
Customer's Spec. No.:	-----
NDK Spec. No.:	END4689A

Receipt

Charge:

Sales	NDK-I P.Bandera	Tel. ++39-02-96702920	Drawn	Y.Oishi
Engineer	Engineering dept. 3 Y.Oishi	Tel. +81-4-2900-6634	Checked	Y.Akasaka
			Approved	K.Moriya

Revision Record

Rev.	Rev. Date	Items	Contents	Remarks
----	17.Mar.2014	Issue		

1. Type

NZ2520SD

2. NDK Spec. No.

END4689A

3. Maximum Ratings

3.1 Supply Voltage (V_{CC})

-0.6 ~ +6.0 V DC

3.2 Storage Temp.

-55 ~ +125 °C

4. Operating Temp. Range

-40 ~ +85 °C

5. Performance

5.1 Nominal Frequency

25MHz

5.2 Standard Supply Voltage (V_{CC})

+3.3 ± 0.1V

5.3 Current Consumption

Operating : 4.5mA MAX(at 3.3V, 25°C)

Stand-by : 10 μA MAX(at 3.3V, 25°C)

5.4 Output Level

C-MOS

5.5 Load Capacitance

15 pF

6. Electrical characteristics

6.1 Overall Frequency Tolerance (Inclusive of 25°C tolerance, temp. characteristics, and supply voltage change)

±25 × 10⁻⁶ MAX

6.2 Output Voltage

V_{OL} ; 0.1 V_{CC} MAX

V_{OH} ; 0.9 V_{CC} MIN

6.3 Rise Time (T_r) / Fall Time(T_f)

6 ns MAX (0.1 V_{CC} ~0.9 V_{CC})

6.4 Symmetry

45 ~ 55 % (at 1/2 V_{CC})

6.5 Output Wave Form

Rectangular

6.6 Start-up Time

4 ms MAX

6.7 Phase Noise

-148dBc/Hz TYP (1kHz offset, at 3.3V, 25°C, F=40MHz)

-156dBc/Hz TYP (100kHz offset, at 3.3V, 25°C, F=40MHz)

6.8 Stand-by function

#1 PAD input	# 3 PAD output
H level (0.7 V_{CC} ~ V_{CC}) or open	Operating
L level (0.3 V_{CC} MAX)	High impedance

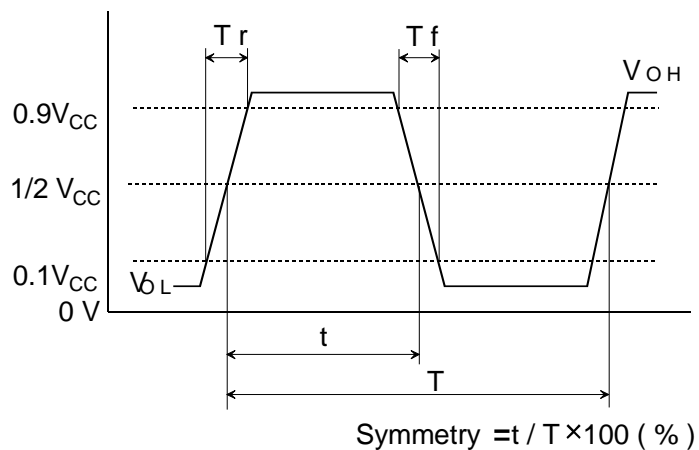

7. Measuring circuits

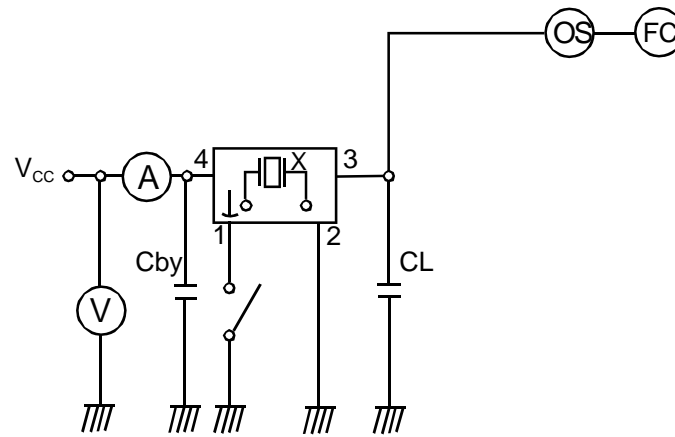

CL ; 15pF MAX including input capacity of osilloscope

Cby ; Bypass capacitor (0.01 μ F)

8. Test data will not be submitted.

9. Application drawing

9.1 Dimension drawing

EKD14B-00027

9.2 Marking drawing

EKH11B-00052

9.3 Reliability assurance Item

EKS30B-00060

9.4 Taping & Reel drawing

EKK17B-00032

10. Instruction Notice

10.1 Noise

When the NZ2520S series are used, the 0.01 μ F capacitor should be connected between V_{CC} and GND line. (Closer to the product terminal is desirable.)

10.2 Resistance to dropping

The NZ2520S series is designed to be impactproof so that no damage occurs when dropped a height(75 cm) three times. However, if dropped from a desk etc., it is advisable to check their performance or contact us to check it.

10.3 Electrostatic protection

The NZ2520S series employ C-MOS ICs for the active element. Please use them in static-free environments.

10.4 High temperature

Normal operation cannot be guaranteed for the NZ2520S series at +125°C(for 24 hours). Be sure that the units are kept within the specified temperature range.

10.5 Cleaning

Basically, the NZ2520S series are applicable for ultrasonic wave cleaning. However, in some case, during ultrasonic wave cleanings, internal design may get damage. Please check condition carefully beforehand.

10.6 Other

The NZ2520S series are C-MOS applied products. And careful handling(same as with C-MOS IC) are needed to avoid electrostatic problems.

Incorrect PAD connection is cause of trouble. Please make sure to connect correctly as below.

#2 terminal \rightarrow GND

#4 terminal \rightarrow V_{CC}

11. Notice

- 11.1 Order items are manufactured according to specification. As to conditions, which are not indicated in this specification and unpredictable such as applied condition and oscillation margin, please check them beforehand.
- 11.2 Unless we receive request for modification within 3 weeks from the issue date of this NDK specification sheet, we will supply products according to this specification. Also, if you'd like to modify specification of order, which has been placed with delivery request within 3 weeks from the issue data of this specification sheet, we would like to discuss with you separately.
- 11.3 In no event shall the company be liable for any product failure resulting from an inappropriate handling or operation of the product beyond the scope of its guarantee.
- 11.4 Where any change to the process condition is made due to the change(s) in the production line, inform personnel of the specifications.
- 11.5 Should this specification data give rise to any disputes relating to any intellectual property rights or any other rights of a third person, the company shall not indemnify anyone for any damage. Their disclosure must not be construed as the grant of a license to use any of the intellectual property rights owned by the company.
- 11.6 If you intend to use products listed on this specification for applications that may result in loss of life or assets (controls relating to safety, medical equipment, aeronautical equipment, space equipment, etc.), please do not fail to advise us of your intention beforehand.
- 11.7 In the company's production process whatever amount of ozone depleting substances (ODS) as specified in the Montreal protocol is not used.
- 11.8 Information contained in this specification must not be quoted, reproduced or used for other purposes including processing either in part or in full without obtaining prior approval from the company.
- 11.9 The appearance color and so on have a different case by purchasing it more than 2 suppliers of the component, but characteristic and reliability are guaranteed.

12. Prohibited items

Be sure to use the product under the following conditions. Otherwise, the characteristics deterioration or destruction of the product may result.

(1)Reflow soldering heat resistance

Peak temperature: 265°C, 10 sec

Heating: 230°C or higher, 40 sec

Preheating: 150°C to 180°C, 120 sec

Reflow passage times: 3 times

(2)Manual soldering heat resistance

Pressing a soldering iron of 350°C on the terminal electrode for 3 seconds.

*Example For Soldering Conditions (The below graph corresponds to Pb free solder)

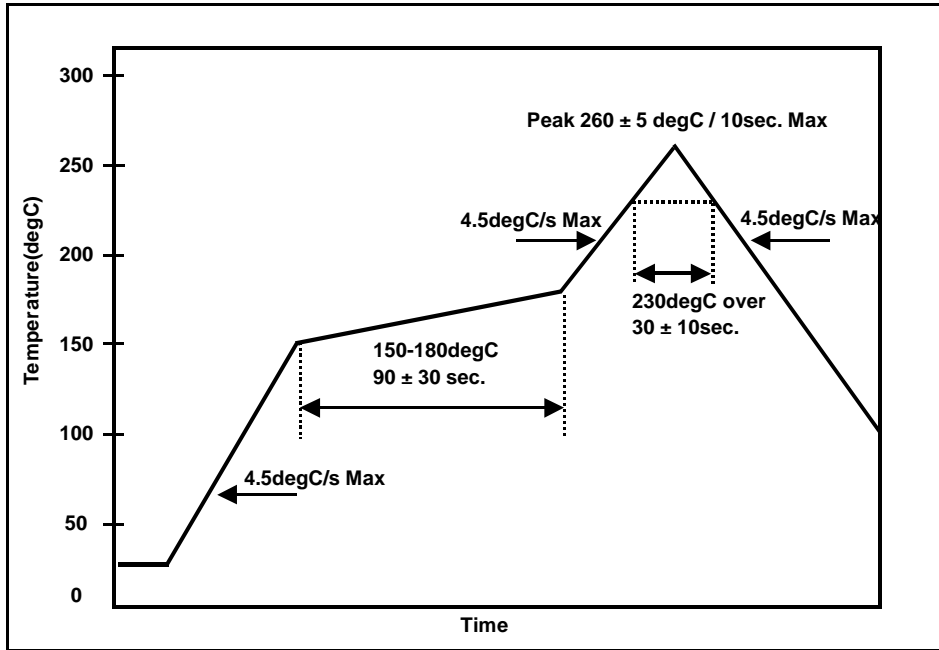

* Recommended footprint

[mm]

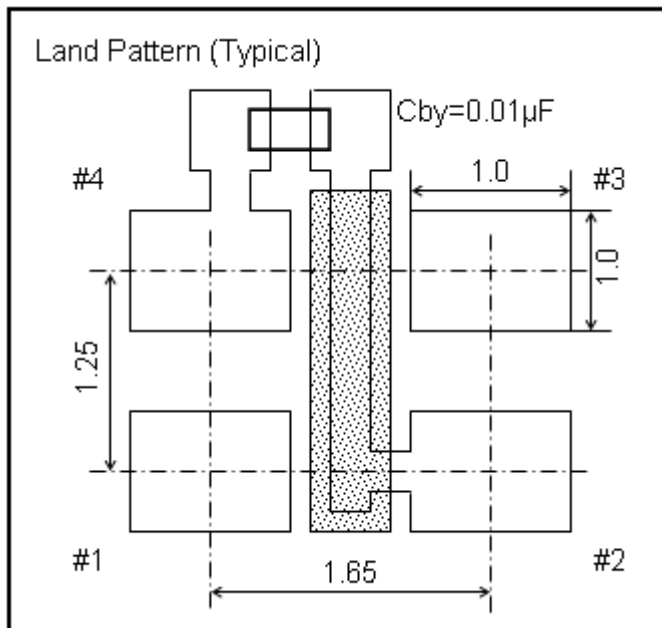

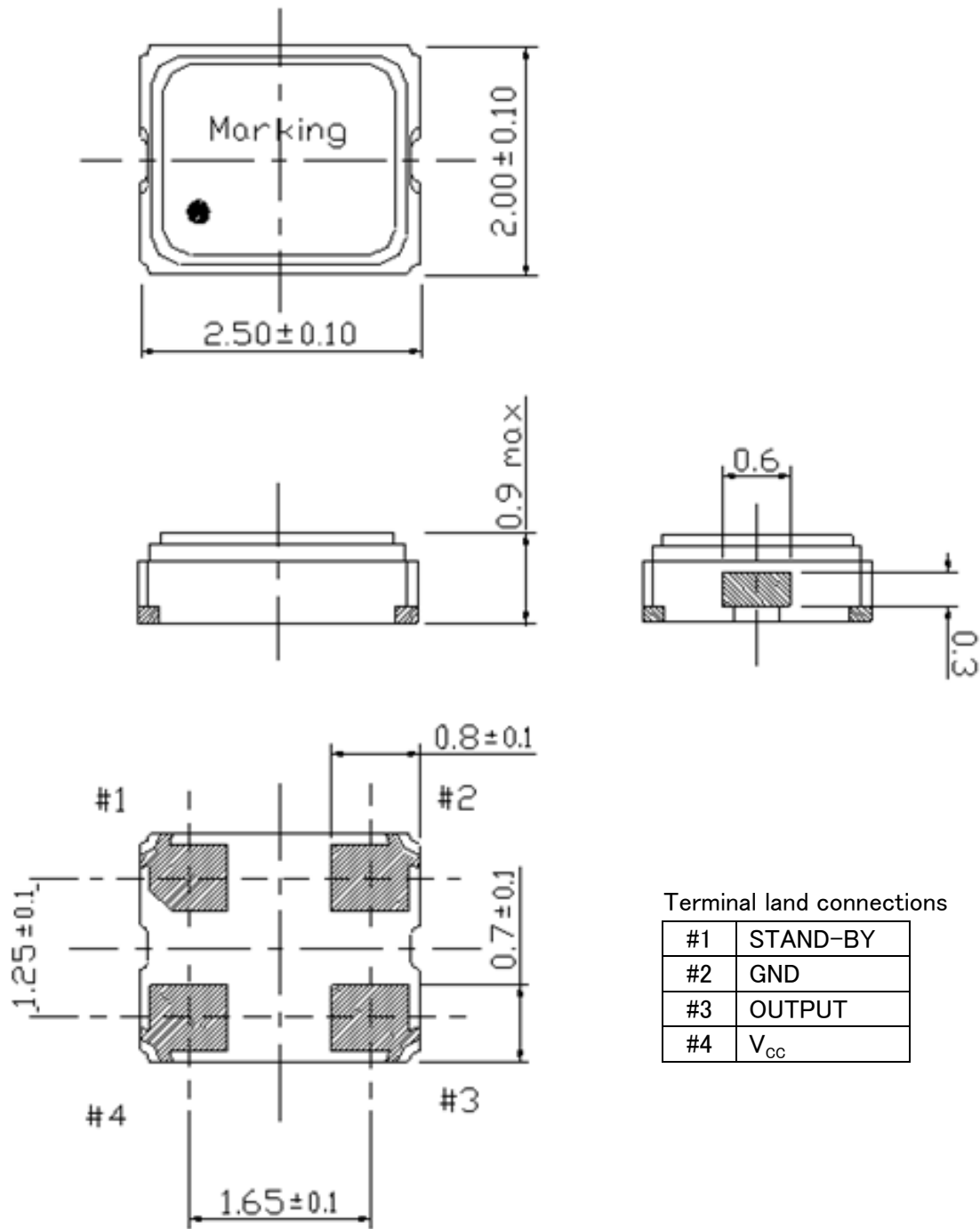

	Date of Revise	Charge	Approved	Reason	
C	2.Aug.2012	Y.Oishi	C.Ishimaru	Change V _{DD} →V _{CC} , PAD CONNECTIONS→Terminal land connections	
	Date	Name	Third Angle Projection	Tolerance	
Drawn	23.Oct.2003	M.Yamaguchi	Dimension : mm	-----	
Designed	27.Jun.2003	M.Yamaguchi	Title	Drawing No.	
Checked	-----	-----			
Approved	23.Oct.2003	H.Omata			
			NZ2520S Dimension of External	EKD14B-00027	Rev. C

NIHON DEMPA KOGYO CO., LTD.

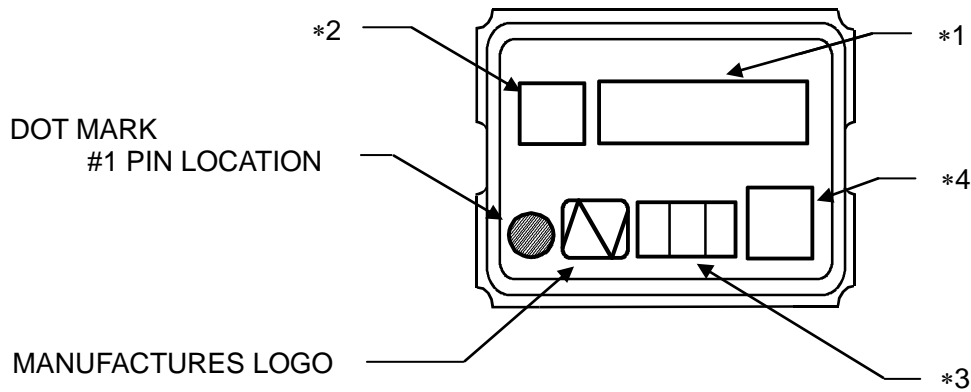

***1 [FREQUENCY]**

Digits are five and 6TH digit will be omitted.
 MHz unit sign is not marked.
 ex,) 28.63636MHz → 28.636 [Unit sign not marked]

***2 [MODEL MARK]**

A last digit of model is marked. →

[MODEL MARK]	
NZ2520SA	→ Space
NZ2520SB	→ B
NZ2520SC	→ C
NZ2520SD	→ D
NZ2520SEA	→ E
NZ2520SF	→ F
NZ2520SG	→ G
NZ2520SH	→ H

***3 [WEEK CODE (Digit are three)]**

ex1,) In case of 7TH week of 2006

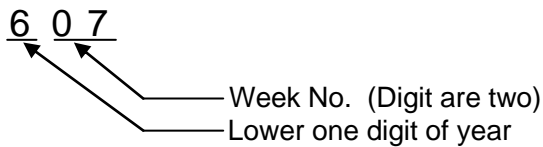

ex2,) In case of 31TH week of 2006

6 3 1

***4 [Trace code]**

Trace code consists of four digits number or letter.
 This code indicates production date and production line number.

	Date of Revise	Charge	Approved	Reason	
G	17.Apr.2013	Y.Oishi	C.Ishimaru	Model mark addition.(NZ2520SH)	
	Date	Name	Third Angle Projection	Tolerance	Scale
Drawn	27.Jan.2006	Y.Oishi	mm	-----	-----
Designed	27.Jan.2006	Y.Okajima	Title	Drawing No.	Rev.
Checked	27.Jan.2006	C.Ishimaru			
Approved	27.Jan.2006	H.Omata			
			NZ2520S Marking	EKH11B-00052	G

NIHON DEMPA KOGYO CO., LTD.

Environmental Test Conditions	Specification
1. Thermal Shock Test 1 cycle: -40°C (30 minutes) ~ +85°C(30 minutes) Number of cycle: 100 cycle.	*1
2. High Temperature High Humidity Test Temperature : +85°C, Humidity : 80 ~ 85%, Time : 250 hours.	*1
3. +85°C Aging (Non Operating) Temperature : +85°C, Time : 500 Hours.	*1
4. Vibration Test MIL-STD-202F test method:204D Test condition : D 10 ~ 2000Hz, 1.52mmp-p, or 196m/s ² 20 minutes/cycle, XYZ 3 directions 4 times.	*1
5. Shock Test MIL-STD-202F test method : 213B Test condition : Half sinusoidal wave 29400m/s ² , 0.3ms, 3 directions, 3 times each.	*1
6. Drop Test (JIG attachment) Dummy load : 200g, Height : 1.5m, Fall conditions : On concrete The number of times of fall : Six directions and 1 time each are made into 1 cycle, and it is 10 cycle.	*1
7. Soldering Test (Reflow) Pre heat : 150±10°C, 60~120sec. Main heat : 30±1 seconds after amounting to 215 °C. Peak temperature : 240°C	More than 90% of should be covered by solder.
8. Soldering Resistance (Reflow) Pre heat : 180±10°C, 120 sec min, Main heat : 225°C min, 70sec max. Peak temperature : 260°C . Reflow time : 3 times.	*1
<p>*1 After the test mentioned above, the electrical specifications are satisfied. Also frequency deviation before and after test should be</p> $\Delta F/F \leq \pm 10 \times 10^{-6}$ <p>The electrical specifications are I_{CC}, T_r/T_f, V_{OL}/V_{OH}, duty cycle, stand-by function, stand-by current consumption.</p>	

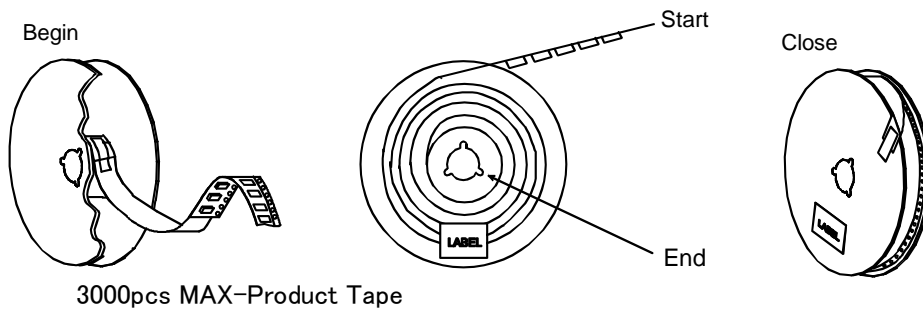
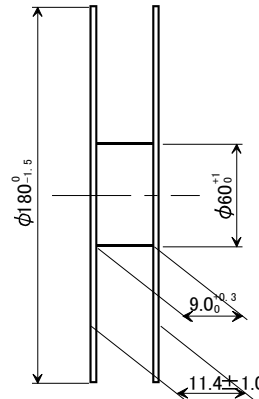
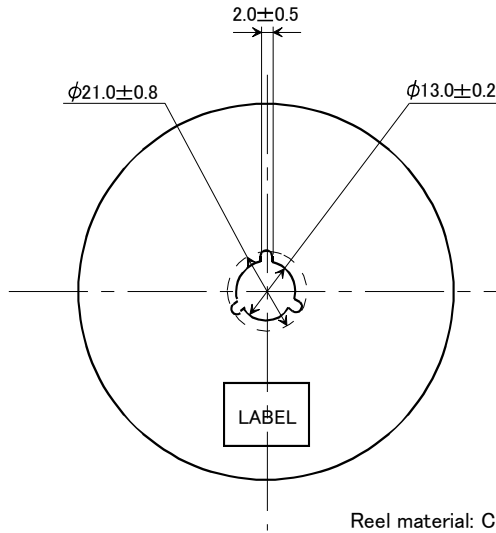
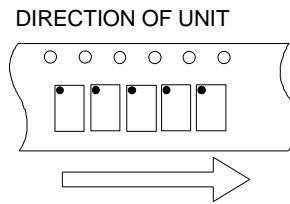
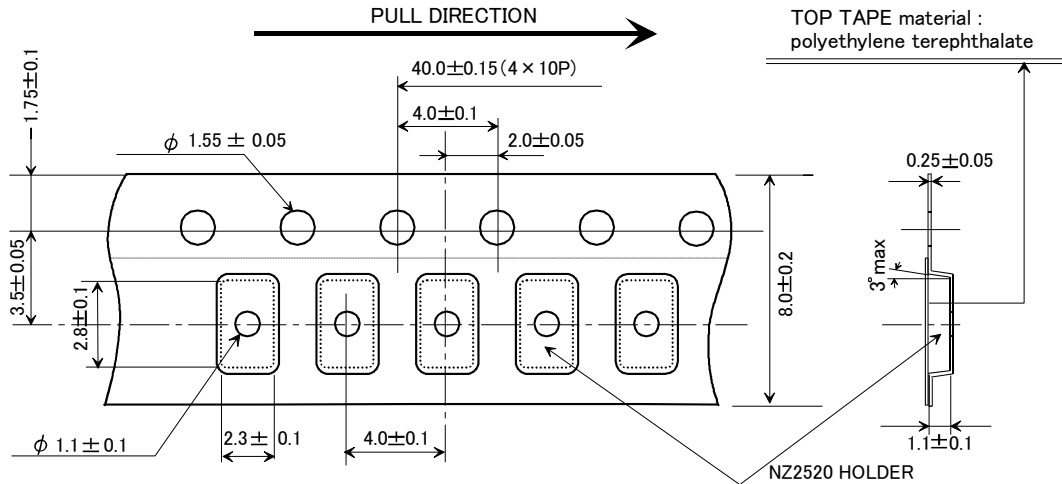

	Date of Revise	Charge	Approved	Reason		
C	5.Sep.2012	Y.Oishi	C.Ishimaru	3000pcs-Product Tape→3000pcs MAX-Product Tape.		
	Date	Name	Third Angle Projection	Tolerance		
Drawn	7.Oct.2003	Y.Okajima	Dimension:mm	Scale		
Designed	7.Oct.2003	Y.Okajima	Title	Drawing No.		
Checked					NZ2520	EKK17B-00032
Approved	7.Oct.2003	H.Omata				
				C		

NIHON DEMPA KOGYO CO., LTD.