

Crystal Clock Oscillator

NZ2520S Series

(32.768kHz)

Model name

NZ2520SB Overall frequency tolerance of $\pm 50 \times 10^{-6}$.

Application

For Mobile Phone, Tablet computer, and automobile audio equipment, etc)



Pb
Free

RoHS Compliant
Directive 2011/65/EU

Features

- Compact and light. Dimensions : 2.5 x 2.0 x 0.9 mm, weight : 0.02 g.
- This product applied AT-cut crystal blank which has a superior frequency stability. So, narrow deviation ($\pm 50 \times 10^{-6}$) and quick oscillation start up time (1ms typ) are available.

Absolute maximum rating
Supply voltage (V_{CC}) -0.3 to $+5.0$ V
Storage temperature range -55 to $+125$ °C

Specifications

Item		Model	NZ2520SB		
Output level			CMOS		
Nominal frequency range *1		(kHz)	32.768		
Operating temperature range *2		(°C)	-40 to +85		
Overall frequency tolerance		($\times 10^{-6}$)	± 50		
Supply voltage (V_{CC})		(V)	1.8	2.5	3.3
Current consumption max	During operation (25 °C)	(mA)	0.22 (0.11 typ.)	0.24 (0.12 typ.)	0.26 (0.13 typ.)
	During standby	(μ A)	10		
$V_{OL\ max}/V_{OH\ min}$		(V)	$0.1 V_{CC}/0.9 V_{CC}$		
$T_r\ max/T_f\ max$		(ns)	200/200 (at 0.1 V_{CC} to 0.9 V_{CC})		
Symmetry min. to max.		(%)	45 to 55 (at 0.5 V_{CC})		
Load (C_L) max		(pF)	15		
Start-up time max		(ms)	5		
Frequency aging max		($\times 10^{-6}$)	± 5 (+25°C, First year)		
Standby function			Available (Three-state)		

*1: If you require a product with a frequency not given above, please contact us.

*2: If you require a product with an operating temperature range not given above, please contact us.

List of Codes for Placing an Order

List of Codes for Placing an Order (The purchase order number differs according to the difference in supply voltage.)		NSA3534B	NSA3535B	NSA3536B
Supply voltage (V_{CC})	(V)	+1.8 \pm 0.18	+2.5 \pm 0.25	+3.3 \pm 0.33

Crystal Clock Oscillator

NZ2520S Series

(32.768kHz)

■ Dimensions

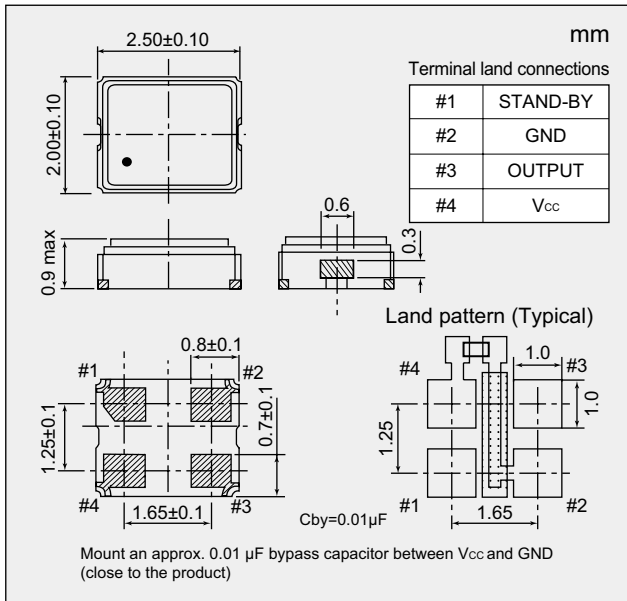

■ Output Waveform <CMOS>

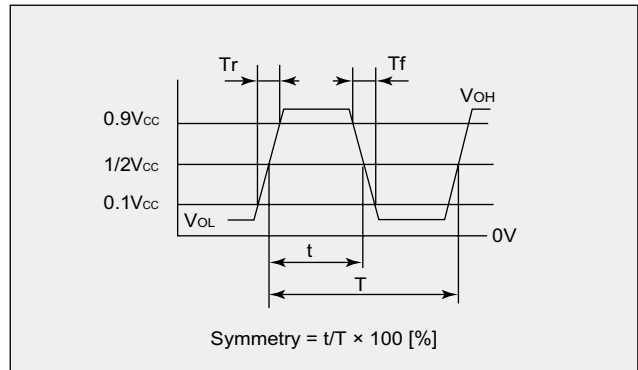

■ Standby Function

#1 Input	#3 Output
Level H ($0.7 V_{CC} \leq V_{IH} \leq V_{CC}$) or OPEN is selected.	Oscillation output ON
Level L ($V_{IL} \leq 0.3 V_{CC}$) is selected.	High impedance

■ How to Specify an Order

When ordering our products, specify them with an "Ordering Code" that consists of the following:

Model name – Frequency (up to 9 digits) k – Number for specifying an order

Example 1: When ordering a product with model name: NZ2520SB, frequency: 32.768kHz, overall frequency tolerance: $\pm 50 \times 10^{-6}$, and supply voltage: 1.8 V

Ordering Code: NZ2520SB – 32.768000K – NSA3534B

Example 2: When ordering a product with model name: NZ2520SB, frequency: 32.768kHz, overall frequency tolerance: $\pm 50 \times 10^{-6}$, and supply voltage: 3.3 V

Ordering Code: NZ2520SB – 32.768000K – NSA3536B

If you have any queries concerning our standard frequencies and numbers for specifying orders, please contact our sales representatives or visit our homepage (<http://www.ndk.com/>).