



SPECIFICATION

Customer: ELTECH

Item:	Simple Packaged Crystal Oscillator (SPXO)
Type:	NZ2016SN
Nominal Frequency:	24.576 MHz
Customer's Spec. No.:	---
NDK Spec. No.:	END5874A

Receipt

Revision Record						
Rev.	Date	Items	Contents	Approved	Checked	Drawn
---	20.May.2020	Issue	---	S.Murase	---	Y.Okajima

- 1. Customer's Spec. No. : ---
- 2. NDK Spec. No. : END5874A
- 3. Type : NZ2016SN

4. Maximum Ratings

	Item	Ratings			Notes
		min	max	Units	
1	Supply Voltage	-0.3	+4.0	V	
2	Input Voltage	-0.3	V _{CC} +0.3	V	
3	Storage Temperature Range	-55	+125	°C	

5. Electrical Specifications

(Unless otherwise noted, TA=-40 to +125 °C, V_{CC}=1.8 V, Load=15 pF)

	Parameters	SYM	Electrical Spec.				Notes
			min	typ	max	Units	
1	Nominal Frequency	f _{nom}		24.576		MHz	-
2	Supply Voltage	V _{CC}	1.7	1.8	1.9	V	-
3	Current Consumption (Operating)	I _{CC}			20	mA	at 25 °C
4	Output Level	-	CMOS				-
5	Load Capacitance	C _L			15	pF	-
6	Operating Temperature Range	T _{opr}	-40		+125	°C	-
7	Overall Frequency Tolerance	Δf/f _{nom}	-100		+100	ppm	(*1)
8	Output Voltage	V _{OL}			0.25 V _{CC}	V	-
		V _{OH}	0.75 V _{CC}			V	-
9	Rise Time(t _r), Fall Time(t _f)	t _r /t _f			6	ns	0.2 V _{CC} to 0.8 V _{CC}
10	Symmetry	SYM	40		60	%	at 1/2 V _{CC}
12	Modulation Output Clock Mode	-	# 1 selectable (*2)				See table (*4)
13	Modulation Output Deviation range	-	±0.59			%	at 25 °C (*3)
14	Output Wave Form	-	Square wave				-
15	Stand-by Function	-	No				-

*1 Inclusive of Freq. tolerance (at 25 °C), frequency/temperature characteristics, frequency/voltage coefficient.

*2 Modulated clock will be enabled if # 1 is Logic "1" or open.

Non-modulated clock will be enabled if # 1 is Logic "0".

*3 The deviation range can vary by ±20%

*4 PAD Definition

PAD	Symbol	Functionality
#1	EN	Modulation Output Clock Mode H(Logic"1"):Enable, L (Logic"0"):Disable Internal pull high resistor
#2	GND	Ground
#3	OUTPUT	Oscillator output
#4	V _{CC}	Supply voltage

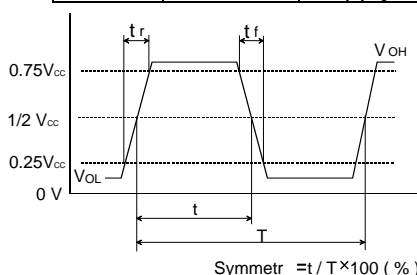

6. Measuring circuits

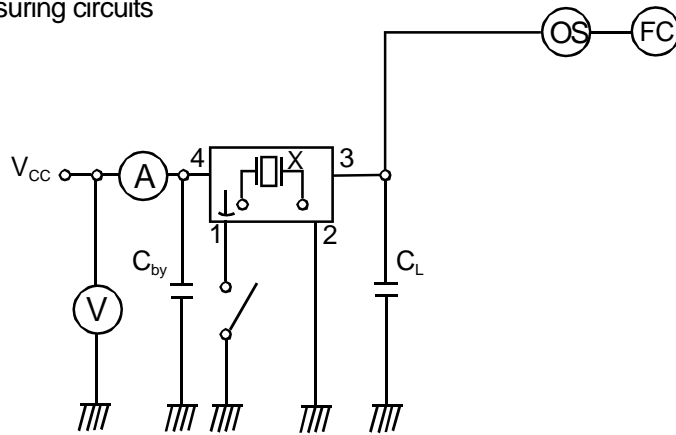

C_L ; 15pF MAX including input capacity of oscilloscope

C_{by} ; Bypass capacitor (0.01uF)

7. Test data will not be submitted

8. Application drawing

8.1 Dimension drawing

EKD14B-00112

8.2 Marking drawing

EKH11B-00085

8.3 Reliability assurance Item

EKS30B-00092

8.4 Taping & Reel drawing

EKK17B-00076

EEK17B-00015

9. Instruction Notice

9.1 Noise

When the NZ2016S series are used, the 0.01 μ F capacitor should be connected between V_{CC} and GND line. (Closer to the product terminal is desirable.)

9.2 Resistance to dropping

The NZ2016S series is designed to be impactproof so that no damage occurs when dropped a height (75 cm) three times. However, if dropped from a desk etc., it is advisable to check their performance or contact us to check it.

9.3 Electrostatic protection

The NZ2016S series employ C-MOS ICs for the active element. Please use them in static-free environments.

9.4 High temperature

Normal operation cannot be guaranteed for the NZ2016S series at +125°C(for 24 hours). Be sure that the units are kept within the specified temperature range.

9.5 Cleaning

Basically, the NZ2016S series are applicable for ultrasonic wave cleaning. However, in some case, during ultrasonic wave cleanings, internal design may get damage. Please check condition carefully beforehand.

9.6 Other

The NZ2016S series are C-MOS applied products. And careful handling (same as with C-MOS IC) are needed to avoid electrostatic problems.

Incorrect PAD connection is cause of trouble. Please make sure to connect correctly as below.

#2 terminal \rightarrow GND

#4 terminal \rightarrow V_{CC}

10. Notes On Use

10.1 Even if the appearance color etc. of the product differs by purchasing the component parts by more than two companies, there is no influence on the characteristics and reliability.

10.2 IN THE CASE OF THE FOLLOWING ITEMS, WE ARE NOT RESPONSIBLE FOR WARRANTY / COMPENSATION.

(1) WHEN PRODUCTS OF THIS SPECIFICATION ARE USED FOR EQUIPMENT RELATED TO HUMAN LIFE OR PROPERTY, IT IS THE RESPONSIBILITY OF THE CUSTOMER TO CONFIRM THE INFLUENCE ON THIS PRODUCT AND EQUIPMENT TO BE USED BEFOREHAND, CONDUCT NECESSARY SAFETY DESIGN (INCLUDING REDUNDANT DESIGN, MALFUNCTION PREVENTION DESIGN, etc.), PLEASE USE IT AFTER SECURING SUFFICIENT SAFETY OF EQUIPMENT.

1. SAFETY-RELATED EQUIPMENT SUCH AS AUTOMOBILES, TRAINS, SHIPS, etc., OR EQUIPMENT DIRECTLY INVOLVED IN OPERATION

2. AIRCRAFT EQUIPMENT

3. SPACE EQUIPMENT

4. MEDICAL EQUIPMENT

5. MILITARY EQUIPMENT

6. DISASTER PREVENTION / CRIME PREVENTION EQUIPMENT

7. TRAFFIC LIGHT

8. OTHER EQUIPMENT REQUIRING THE SAME PERFORMANCE AS THE ABOVE-MENTIONED EQUIPMENT

(2) IN CASES WHERE IT IS NOT INDICATED IN THE REQUESTED STANDARD AND IS USED UNDER CONDITIONS OF USE (INCLUDING CIRCUIT MARGIN etc.) THAT CAN NOT BE PREDICTED AT THE PRODUCTION STAGE.

(3) WHEN USING ULTRASONIC WELDING MACHINE. (THERE IS A POSSIBILITY THAT THE CHARACTERISTIC DEGRADATION IS CAUSED BY THE RESONANCE PHENOMENON OF THE PIEZOELECTRIC MATERIAL. (EXAMPLE; CRYSTAL PIECE))

WE WILL NOT TAKE ANY RESPONSIBILITY FOR THE INFLUENCE OF THE CUSTOMERS' PROCESS.

SO, PLEASE SUFFICIENTLY EVALUATE AT A SAMPLE STEP WHEN YOU USE ULTRASONIC WELDING MACHINE.

(4) USING RESIN MOLD MAY AFFECT THE PRODUCT CHARACTERISTIC.

PLEASE MAKE SURE TO TELL OUR SALES CONTACT WHEN YOU USE RESIN MOLD. WE WILL PERFORM INDIVIDUAL CORRESPONDENCE ABOUT A DELIVERY SPECIFICATION AND A EVALUATION METHOD.

IN ADDITION, IF YOU USE RESIN MOLD WITHOUT CONTACTING US, AND CAUSES DAMAGES AGAINST A CUSTOMER OR A THIRD PARTY, WE WILL NOT BE LIABLE FOR THE DAMAGES AND OTHER RESPONSIBILITIES BECAUSE WE CONSIDER IT IS UNDER SELF-RESPONSIBILITY USING RESIN MOLD.

WE WILL NOT TAKE ANY RESPONSIBILITY FOR THE INFLUENCE OF THE CUSTOMERS' PROCESS. PLEASE EFFICIENTLY EVALUATE AT A SAMPLE STEP WHEN YOU USE RESIN MOLD.

(5) WHEN PERFORMING IMPROPER HANDLING THAT EXCEEDS THE GUARANTEED RANGE.

10.3 This product can not be used for equipment related to the safety of automobiles or equipment directly involved in operation. (example: air bag, TPMS, engine control, steering control, brake control etc.)

11. Notes on storage

11.1 When storing the product in high temperature and high humidity condition for a long time, product characteristics (solderability etc.) and packaging condition may be deteriorated. Please store product at temperature + 5 °C ~ + 35 °C, humidity 85 % RH or less. The product is an electronic component, so please do not storage and use, under a dewing state.

11.2 The product storage deadline is 12 months after delivery in unopened state. Please use within storage deadline. If you exceed storage deadline, please check the product characteristics etc, please use.

12. Other Requests

12.1 Please use this specification only for confirmation of the specification of this product.

12.2 If there is a change request, please contact within three weeks from issue date. If there is no communication, we will deliver the product under the contents of this specification. In addition, if the product delivery date is within 3 weeks and there is a change request, we will consult the processing separately.

12.3 NOTES THAT ARE DESCRIBED IN THIS DOCUMENT, IF YOU DID NOT COMPLY WITH THE PROHIBITIONS, AND OTHER PLEASE, INCLUDING THE FAILURE CORRESPONDENCE OR COMPENSATION OR DAMAGES, WE CAN NOT ASSUME THE RESPONSIBILITY, PLEASE UNDERSTAND.

13. Prohibited items

Be sure to use the product under the following conditions. Otherwise, the characteristics deterioration or destruction of the product may result.

(1) Reflow soldering heat resistance

Peak temperature: 265 °C, 10 sec

Heating: 230 °C or higher, 40 sec

Preheating: 150 °C to 180 °C, 120 sec

Reflow passage times: 3 times

(2) Manual soldering heat resistance

Pressing a soldering iron of 350 °C on the terminal electrode for 3 sec.

Example For Soldering Conditions (The below graph corresponds to Pb free solder)

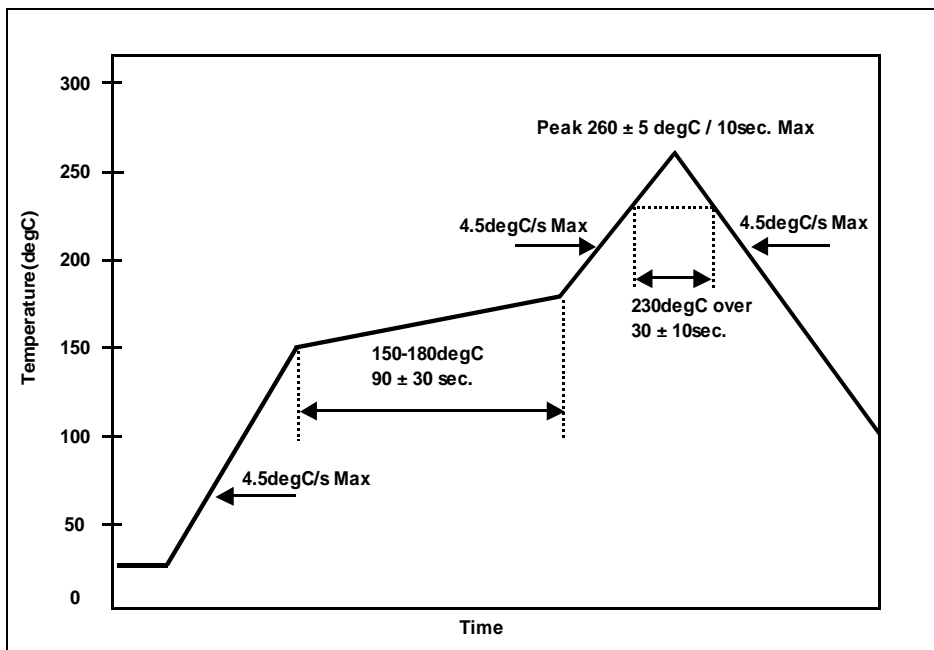

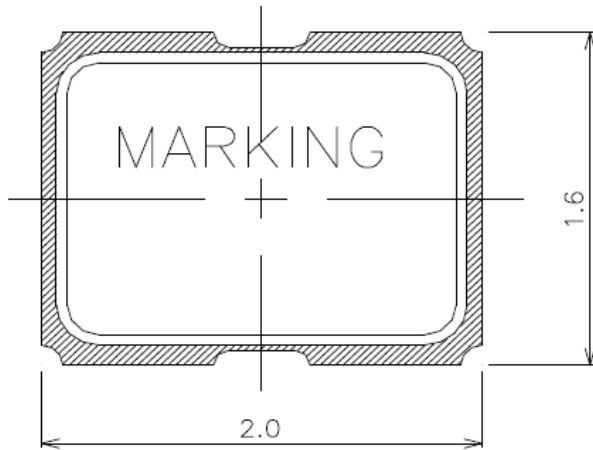

Terminal land connections

#1	EN	Modulation Output Clock Mode Enable Pin H(Logic"1"):Enable L(Logic"0"):Disable Internal pull high resistor
#2	GND	Ground
#3	OUTPUT	Oscillator output
#4	V _{CC}	Supply voltage

Unit:mm

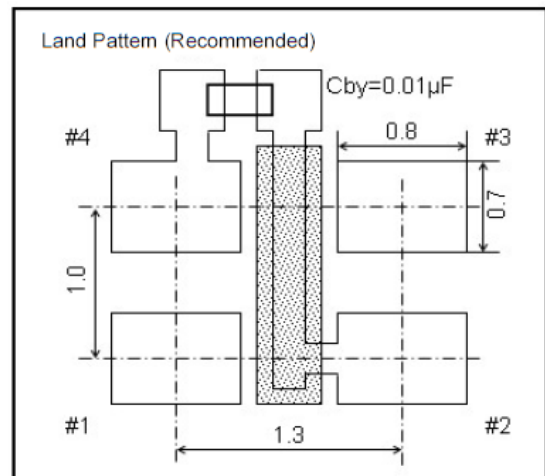
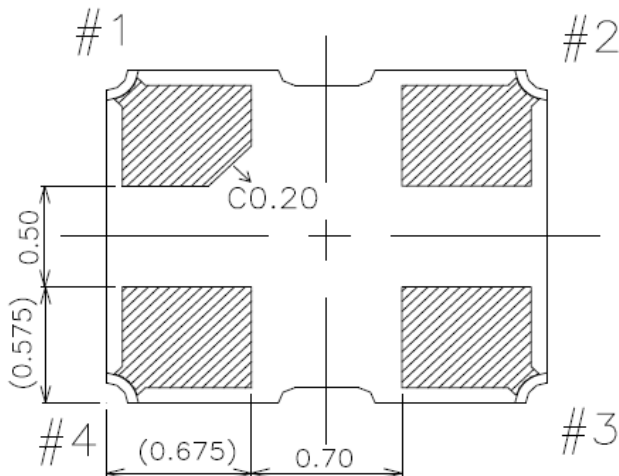
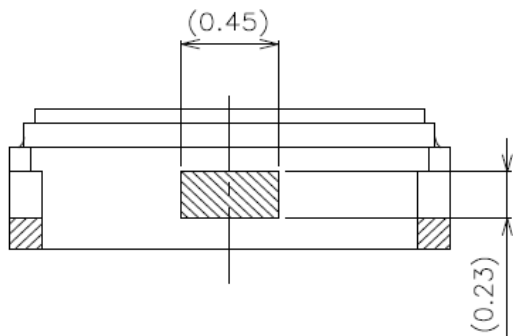

	Date of Revise	Charge	Approved	Reason	
B	14.May.2020	Y.Okajima	S.Murase	Terminal land connections correction	
	Date	Name	Third Angle Projection	Tolerance	Scale
Drawn	27.Dec.2019	Y.Okajima	Dimension:mm	±0.1	-----
Designed	27.Dec.2019	Y.Okajima	Title	Drawing No.	Rev.
Checked	27.Dec.2019	Y.Okajima			
Approved	27.Dec.2019	S.Murase			
			NZ2016SN	EKD14B-00112	B
			Dimension of External		

NIHON DEMPA KOGYO CO., LTD.

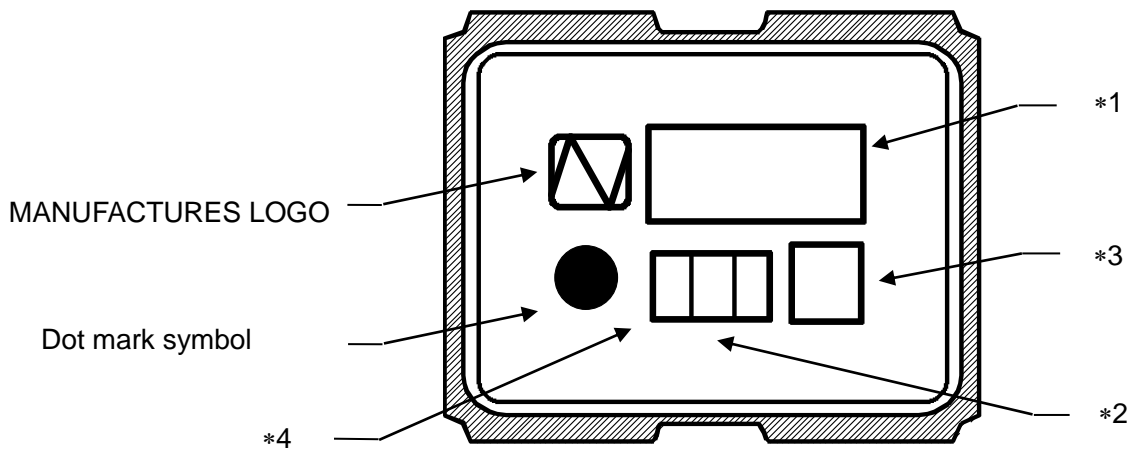

***1 [FREQUENCY]**

Digits are four and 5TH digit will be omitted.
 MHz unit sign is not marked.
 ex,) 28.63636MHz → 28.63 [Unit sign not marked]

***2[Lot Code(Digits are Two)]**

a:First digit:lower one digit of year.
 ex) 2008 →8 , 2009 → 9

b:Second digit:Month No.(See table)

Month	Jan	Feb	Mar	Apr	May	Jun	Jul	Aug	Sep	Oct	Nov	Dec
Month No.	1	2	3	4	5	6	7	8	9	X	Y	Z

***3 [Trace code]**

Trace code consists of four digits number or letter.
 This code indicates production date and production line number.

***4 [Model Symbol]**
 See right table.

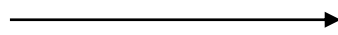

[MODEL MARK]	
NZ2016SD	→ D
NZ2016SDA	→ D
NZ2016SE	→ E
NZ2016SEB	→ E
NZ2016SF	→ F
NZ2016SG	→ G
NZ2016SH	→ H
NZ2016SHA	→ H
NZ2016SJ	→ J
NZ2016SN	→ N

	Date of Revise	Charge	Approved	Reason	
I	27.Dec.2019	Y.Okajima	S.Murase	Model mark "NZ2016SN" is addition.	
	Date	Name	Third Angle Projection	Tolerance	
Drawn	17.Sep.2009	S.Murase	mm	-----	
Designed	17.Sep.2009	S.Murase	Title NZ2016S Marking	Drawing No. EKH11B-00085	
Checked	-----	-----			Rev.
Approved	17.Sep.2009	C.Ishimaru			I

Environmental Test Conditions	Specification
1. Pre- and Post-Stress Electrical Test Refer to AEC-Q200-REV.D TABLE.11 NO.1	*1
2. High Temperature Exposure (Storage) Refer to AEC-Q200-REV.D TABLE.11 NO.3	*3
3. Temperature Cycling Refer to AEC-Q200-REV.D TABLE.11 NO.4	*3
4. Biased Humidity Refer to AEC-Q200-REV.D TABLE.11 NO.7	*2
5. Operational Life Refer to AEC-Q200-REV.D TABLE.11 NO.8	*3
6. External Visual Refer to AEC-Q200-REV.D TABLE.11 NO.9	*4
7. Physical Dimension Refer to AEC-Q200-REV.D TABLE.11 NO.10	*5
8. Resistance to Solvents Refer to AEC-Q200-REV.D TABLE.11 NO.12	*2, *4
9. Mechanical Shock Refer to AEC-Q200-REV.D TABLE.11 NO.13	*2
10. Vibration Refer to AEC-Q200-REV.D TABLE.11 NO.14	*2
11. Resistance to Soldering Heat Refer to AEC-Q200-REV.D TABLE.11 NO.15	*2
12. Solderability Refer to AEC-Q200-REV.D TABLE.11 NO.18	*6
13. Electrical Characterization Refer to AEC-Q200-REV.D TABLE.11 NO.19	*1
14. Board Flex Refer to AEC-Q200-REV.D TABLE.11 NO.21	*7
15. Terminal Strength Refer to AEC-Q200-REV.D TABLE.11 NO.22	*7
<p>*1 After the test mentioned above, the electrical specifications are satisfied.</p> <p>*2 Frequency deviation before and after test should be $\Delta F/F \leq \pm 10 \times 10^{-6}$, Current consumption deviation before and after test should be $\Delta I/I \leq \pm 10\%$.</p> <p>*3 Frequency deviation before and after test should be $\Delta F/F \leq \pm 30 \times 10^{-6}$, Current consumption deviation before and after test should be $\Delta I/I \leq \pm 10\%$.</p> <p>*4 Inspect device construction, marking, and workmanship.</p> <p>*5 External is satisfied.</p> <p>*6 95% min. covered by new solder.</p> <p>*7 Visual inspection to confirm no cracking of materials and no break of sealing.</p> <p>The electrical specifications are I_{CC}, Tr/Tf, V_{OL}/V_{OH}, duty cycle, stand-by current consumption.</p>	

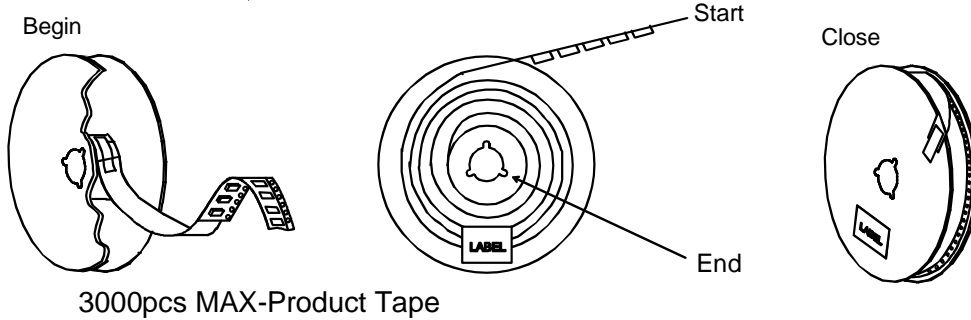
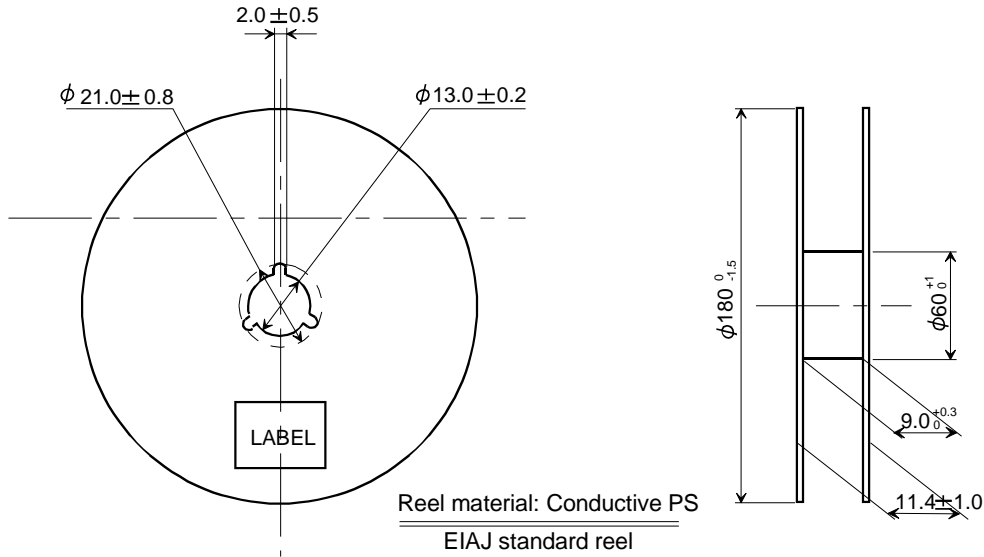
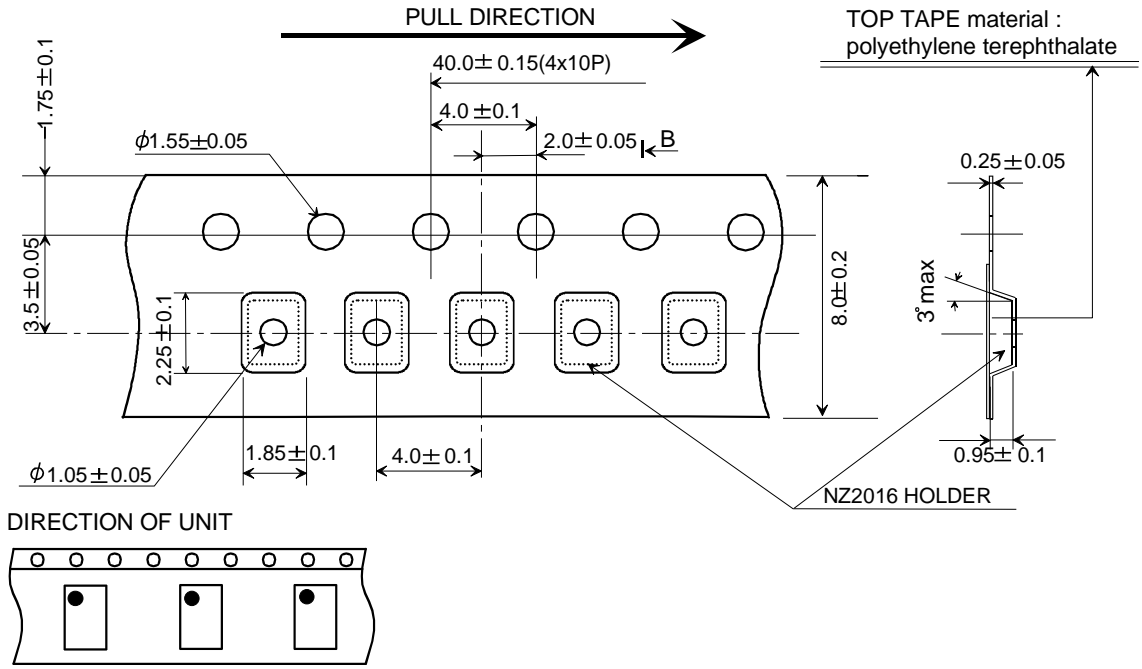

	Date of Revise	Charge	Approved	Reason
B	7.Dec.2015	C.Sakurai	Y.Akasaka	Title of change(NZ2016SA→NZ2016)
	Date	Name	Third Angle Projection	Tolerance
Drawn	18.Jan.2008	S.Murase	Dimension:mm	Scale
Designed	18.Jan.2008	S.Murase	Title	Drawing No.
Checked	-----	-----		
Approved	18.Jan.2008	Y.Nomura		
			NZ2016 Taping and Reel Spec.	EKK17B-00076
				Rev. B

NIHON DEMPA KOGYO CO., LTD.

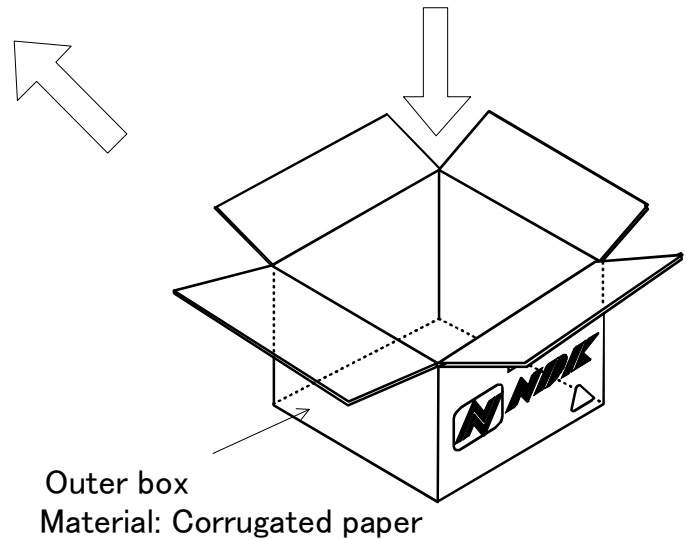
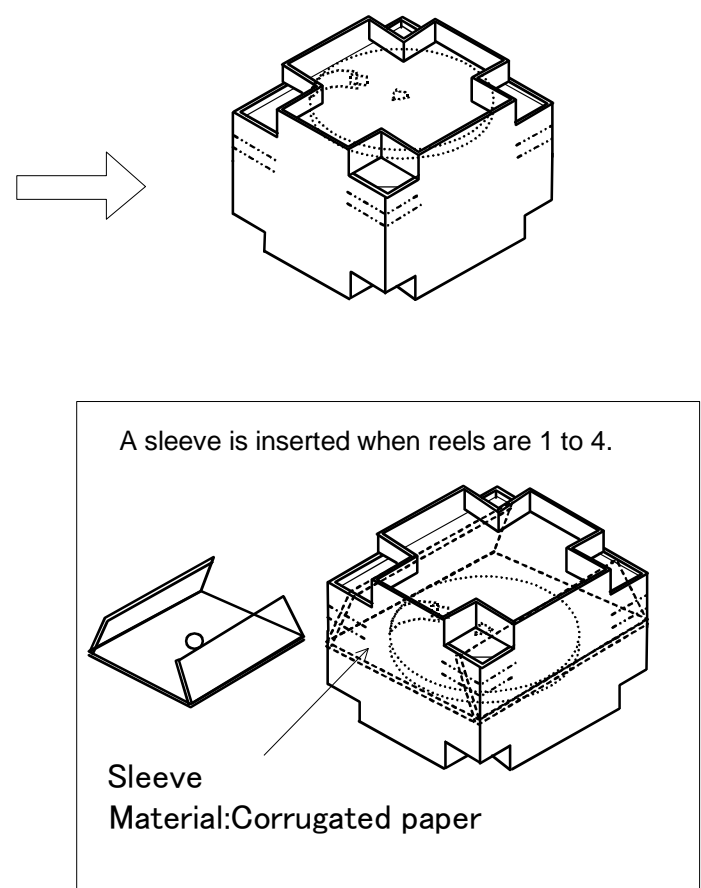
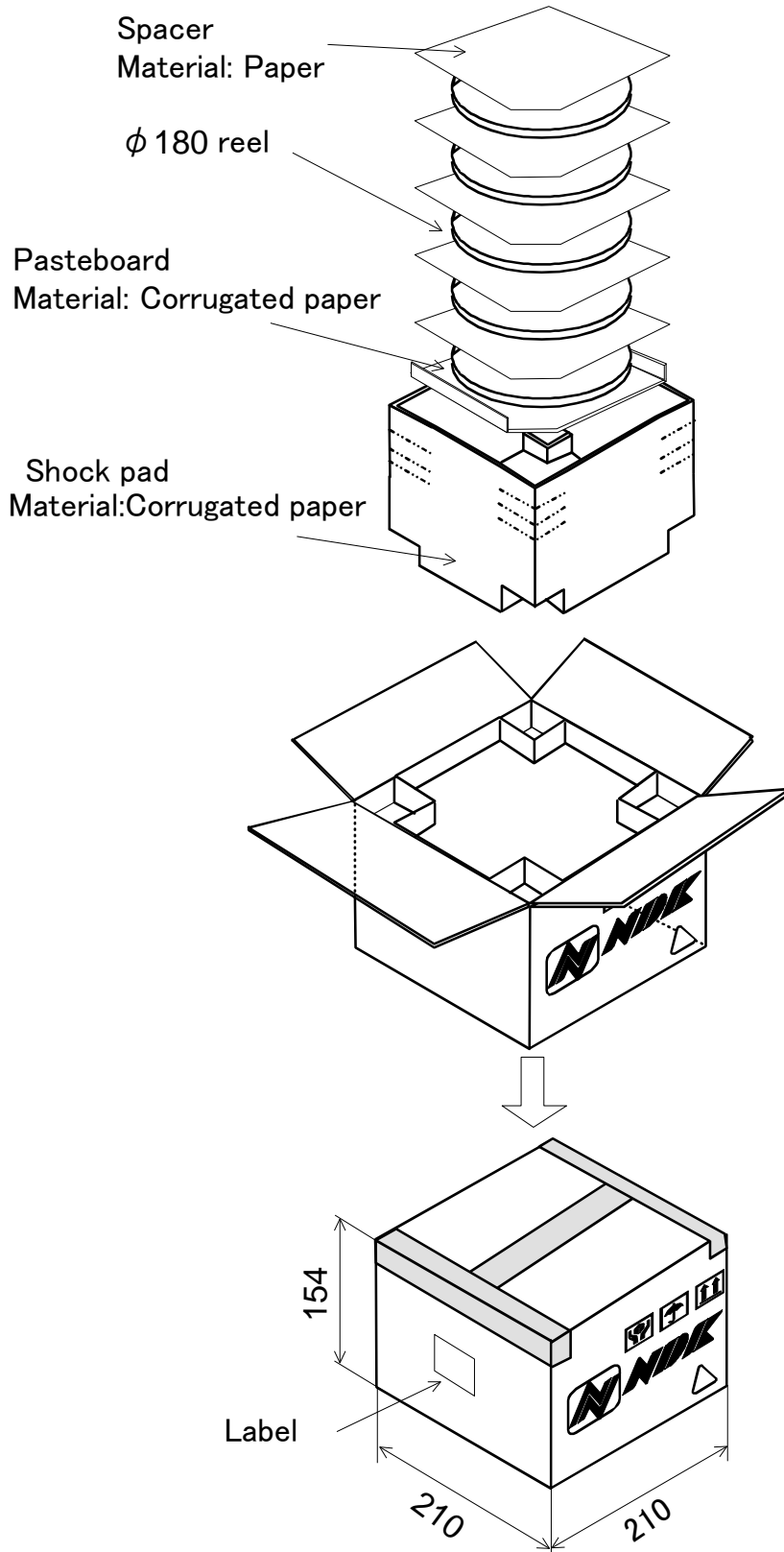

	Date of Revise	Charge	Approved	Reason
C	4 Jul. 2012	H.Ohkubo	K.Oguri	Addition of condition when reels are 1 to 4.
	Date	Name	Third Angle Projection	Tolerance
Drawn	26 Feb. 2010	H. Ohkubo	Dimension:mm	-----
Designed	26 Feb. 2010	K.Oguri	Title	Drawing No.
Checked	26 Feb. 2010	K.Oguri		
Approved	26 Feb. 2010	J. Nakamura		
			180 dia. Reel package	EEK17B-00015
				Rev.
				C

NIHON DEMPA KOGYO CO., LTD.