



# REFERENCE SPECIFICATION

Customer: ELTECH- SpesElectronics

Item	Simple Packaged Crystal Oscillator (SPXO)
Type	NZ2016SK[ ]
Nominal Frequency	32.768 kHz
Customer's Spec. No.	----
NDK Spec. No.	----

For your reference we submit this specification. Please study and keep in your related document file.

Revision Record						
Rev.	Date	Items	Contents	Approved	Checked	Drawn
----	5.Apr.2019	Issue	---	S.Murase	---	M.Kashiwamura

- 1. Customer's Spec. No. : ---
- 2. NDK Spec. No. : ---
- 3. Type : NZ2016SK[ ]

4. Absolute Maximum Ratings

	Item	SYM	Spec. Value				Condition
			Min.	Typ.	Max.	Units	
1	Supply Voltage	$V_{CC}$	-0.3	-	+4.5	V	
2	Storage Temp. Range	$T_{str}$	-55	+25	+125	°C	

5. Electrical Specifications

5.1 - General Electrical Specifications

(Unless otherwise specified, measuring condition  $T = 25^{\circ}C$ ,  $V_{CC} = 3.3V$ , Load = 15pF, )

No	Item	SYM	Electrical Spec.				Condition
			Min.	Typ.	Max.	Units	
1	Nominal Frequency	$f_{nom}$	-	32.768	-	kHz	
2	Supply voltage	$V_{CC}$	1.6	3.3	3.7	V	
3	Current consumption	$I_{CC}$	-	1.0	6	$\mu A$	$V_{CC} = 3.3V$ , No load *1
4	Output Level	-	CMOS				
5	Load Capacitance	$C_L$	-	-	15	pF	
6	Operating Temperature Range	$T_{opr}$	-40	-	+85	°C	
7	Frequency tolerance	$\Delta f/f_{nom}$	-20	-	+20	ppm	+25 °C 3 days average *2
8	Frequency / temperature characteristics	$\Delta f/f$	-30	-	+30	ppm	-40 to +85 °C ,with reference to +25 °C (3 days average) *2
9	Output voltage	$V_{OL}$	-	-	$0.1V_{CC}$	V	
		$V_{OH}$	$0.9V_{CC}$	-	-	V	
10	Symmetry	SYM	45	50	55	%	at $0.5V_{CC}$

Notes

\*1. Average current

\*2. Tolerance of average frequency in operating for three days.

5.5 - Output Waveform

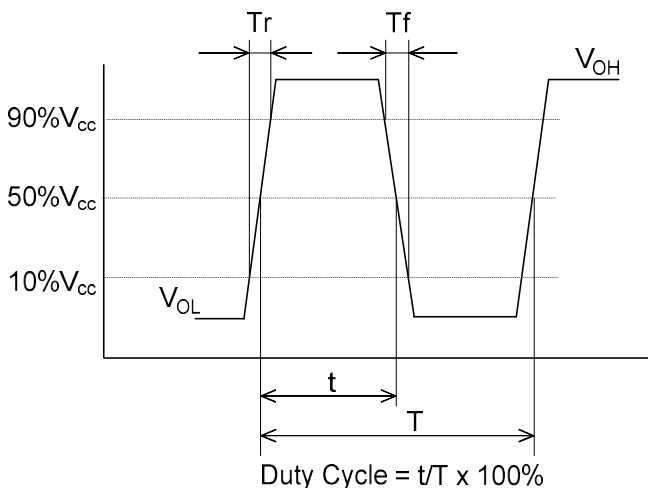

## 6. Measuring circuits

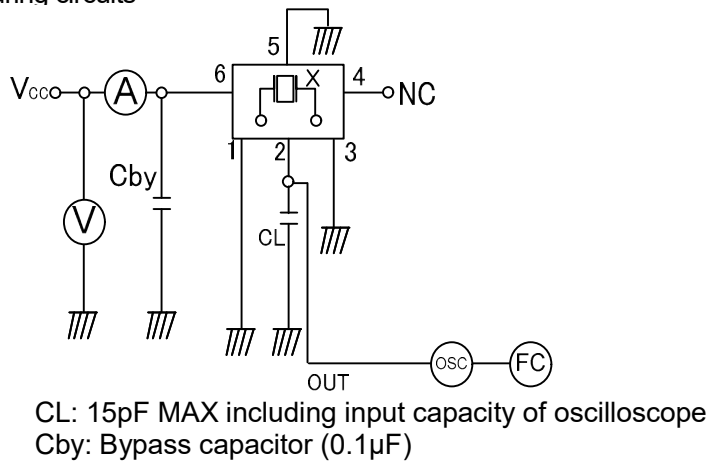

## 7. Test data will not be submitted

## 8. Application drawing

## 8.1 Dimension drawing

EKD14B-00103

## 8.2 Marking drawing

EKH11B-00146

## 8.3 Reliability assurance item

EKS30B-00185

## 8.4 Taping &amp; Reel drawing

EKK17B-00076

## 9. Instruction Notice

## 9.1 Noise

When the NZ2016SK series are used, the 0.1 $\mu$ F capacitor should be connected between  $V_{CC}$  and GND line. (Closer to the product terminal is desirable.)

## 9.2 Resistance to dropping

The NZ2016S series is designed to be impact proof so that no damage occurs. However, if dropped from a desk etc., it is advisable to check their performance or contact us to check it.

## 9.3 Electrostatic protection

The NZ2016S series employ C-MOS ICs for the active element. Please use them in static-free environments.

## 9.4 High temperature

Normal operation cannot be guaranteed for the NZ2016S series at +125 $^{\circ}$ C(for 24 hours). Be sure that the units are kept within the specified temperature range.

## 9.5 Cleaning

Basically, the NZ2016S series are applicable for ultrasonic wave cleaning. However, in some case, during ultrasonic wave cleanings, internal design may get damage. Please check condition carefully beforehand.

## 9.6 Other

The NZ2016S series are C-MOS applied products. And careful handling (same as with C-MOS IC) are needed to avoid electrostatic problems.

Incorrect PAD connection is cause of trouble. Please make sure to connect correctly as below.

#3 terminal  $\rightarrow$  GND

#6 terminal  $\rightarrow$   $V_{CC}$

## 10. Notice

Order items are manufactured according to specification. As to conditions, which are not indicated in this specification and unpredictable such as applied condition and oscillation margin, please check them beforehand.

## 11. Prohibited items

Be sure to use the product under the following conditions. Otherwise, the characteristics deterioration or destruction of the product may result.

## (1) Reflow soldering heat resistance

Peak temperature: 265°C, 10 sec

Heating: 230°C or higher, 40 sec

Preheating: 150°C to 180°C, 120 sec

Reflow passage times: 3 times

## (2) Manual soldering heat resistance

Pressing a soldering iron of 350°C on the terminal electrode for 3 seconds.

Example For Soldering Conditions (The below graph corresponds to Pb free solder)

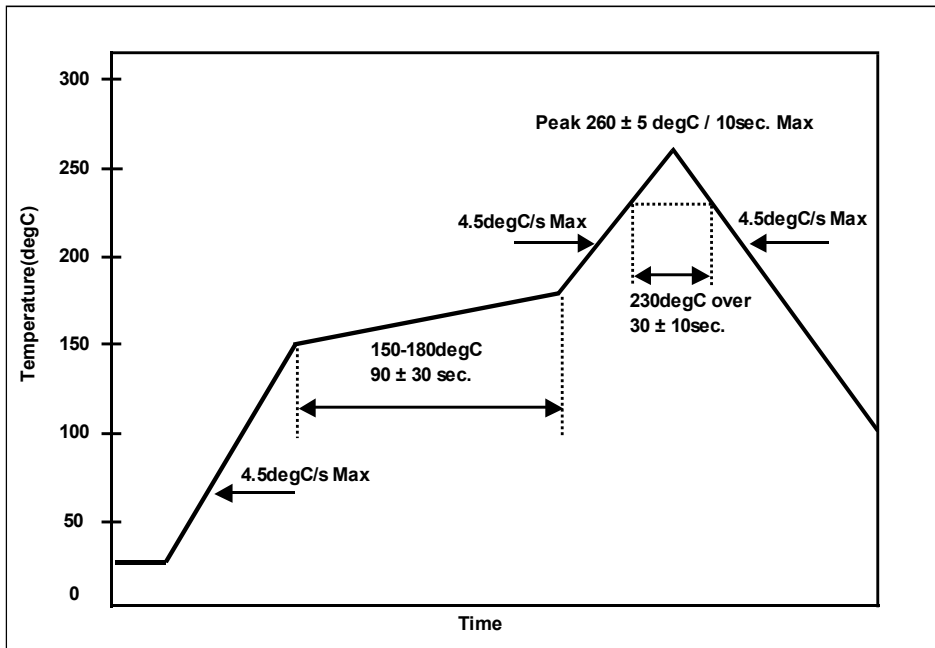

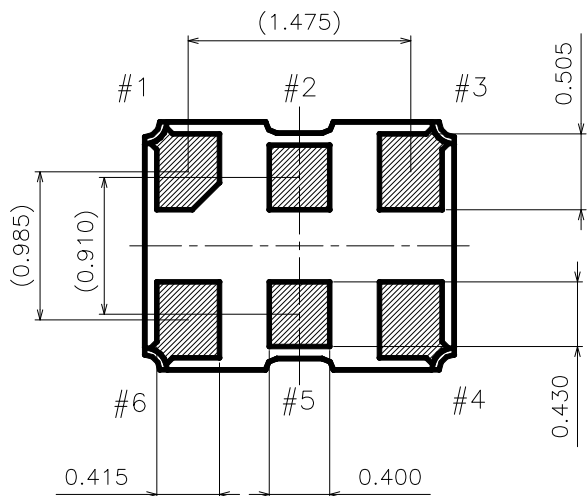
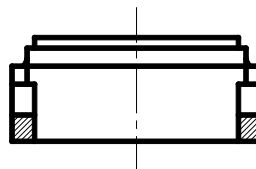
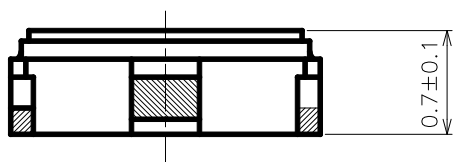
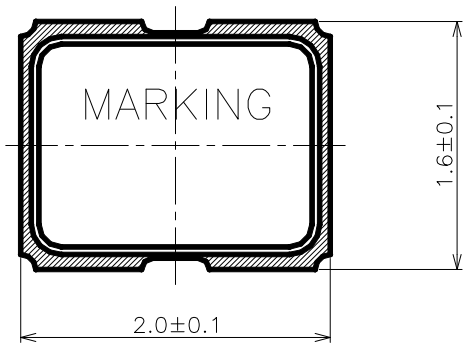

Terminal land connections

#1	GND
#2	Output (32.768kHz)
#3	GND
#4	NC *1
#5	NC *2
#6	Vcc

- \*1 Please remain #4 NC and do not connect to GND.
- \*2 #5 NC is connected to #3 GND by internal routing of package.  
Please remain #5 NC or connect to GND.

Land pattern (Typical)

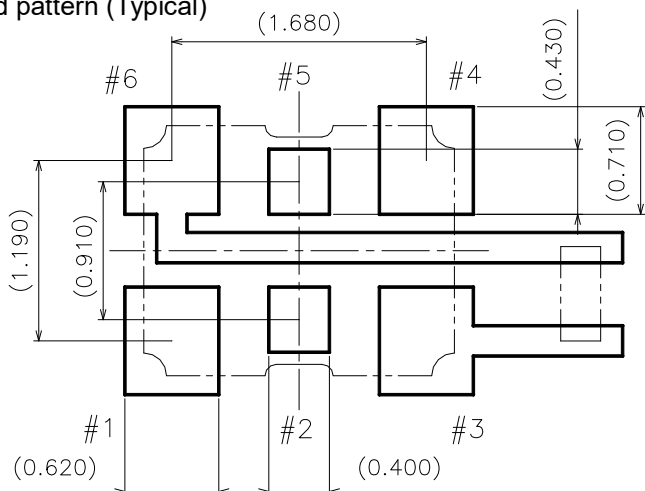

Note

1. Connect an approx. 0.1µF bypass capacitor between Vcc(#6) and GND(#3).  
(Closer to the product terminal is desirable.)

	Date of Revise	Charge	Approved	Reason	
-					
	Date	Name	Third Angle Projection	Tolerance	Scale
Drawn	6.Feb.2018	A.Kanamaru	Dimension :mm	±0.1	20 : 1
Designed	6.Feb.2018	A.Kanamaru	Title <b>NZ2016S External Dimension (Dual outputs)</b>	Drawing No. <b>EKD14B-00103</b>	Rev.
Checked	6.Feb.2018	M.Kashiwamura			-
Approved	6.Feb.2018	S.Murase			

**NIHON DEMPA KOGYO CO., LTD.**

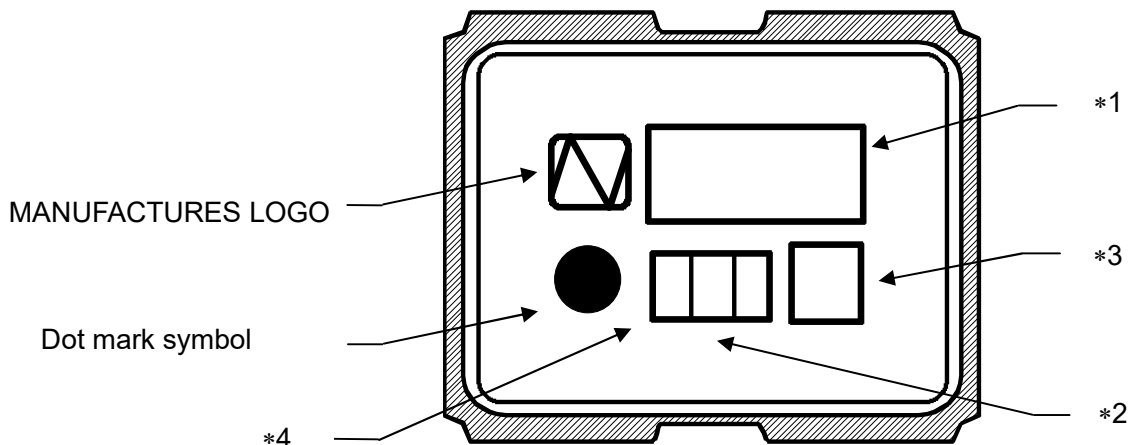

**\*1 [FREQUENCY]**

Digits are two and 3rd digit will be omitted.  
 kHz unit sign is marked.  
 ex, ) 32.768kHz → 32K

**\*2[Lot Code(Digits are Two)]**

a:First digit:lower one digit of year.  
 ex) 2016 → 6

b:Second digit:Month No.(See table)

Month	Jan	Feb	Mar	Apr	May	Jun	Jul	Aug	Sep	Oct	Nov	Dec
Month No.	1	2	3	4	5	6	7	8	9	X	Y	Z

**\*3 [Trace code]**

Trace code consists of four digits number or letter.  
 This code indicates production date and production line number.

**\*4 [Model Symbol]**

See right table.

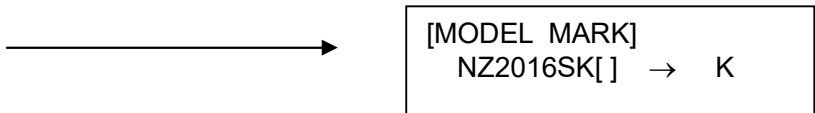

	Date	Name	Third Angle Projection	Tolerance	Scale
Drawn	6.Feb.2018	M.Kahsiwamura	Dimension :mm	-----	-----
Designed	6.Feb.2018	M.Kashiwamura	Title NZ2016S(kHz) Marking	Drawing No. <b>EKH11B-00146</b>	Rev.
Checked	6.Feb.2018	-----			-
Approved	6.Feb.2018	S.Murase			-

**NIHON DEMPA KOGYO CO., LTD.**

No.	Environmental Test	Conditions	Specification
1	Thermal Shock Test	1 cycle: -40°C (30 minutes) ~ +85°C(30 minutes) Number of cycle: 100 cycle.	*1
2	High Temperature High Humidity Test	Temperature : +85°C, Humidity : 80 ~ 85%, Time : 250 hours.	*1
3	+85°C Aging	Temperature (Non-Operating) : +85°C, Time : 500 Hours.	*1
4	Vibration Test	10 ~ 2000Hz, 1.52mmp-p, or 196m/s <sup>2</sup> 20 minutes/cycle, Sweep Time 4 Hours(3 directions,12H each)	*1
5	Shock Test	Test condition : Half sinusoidal wave 29400m/s <sup>2</sup> , 0.3ms, 3 directions, 3 times each.	*1
6	Drop Test (JIG attachment )	Dummy load : 200g, Height : 1.5m, Fall conditions : On concrete The number of times of fall : Six directions and 1 time each are made into 1 cycle, and it is 10 cycle.	*1
7	Soldering Test (Reflow )	Pre heat: 150±10°C, 60~120sec. Main heat: 30±1 seconds after amounting to 215 °C. Peak temperature : 240°C	More than 90% of should be covered by solder.
8	Soldering Resistance ( Reflow )	Pre heat : 180±10°C, 120 sec min, Main heat : 225°C min, 70sec max. Peak temperature : 260°C .Reflow time : 3 times.	*1
<p>*1</p> <ul style="list-style-type: none"> <li>After the test mentioned above, the electrical specifications are satisfied.</li> </ul> <p>The electrical specifications are I<sub>CC</sub>, V<sub>OL</sub>/V<sub>OH</sub>, Symmetry.</p>			

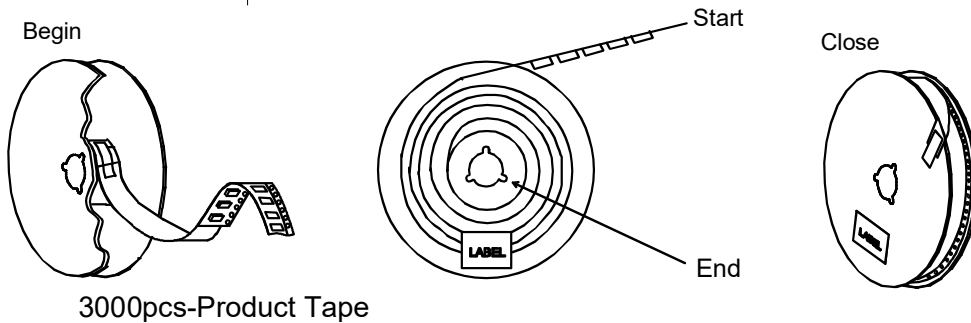
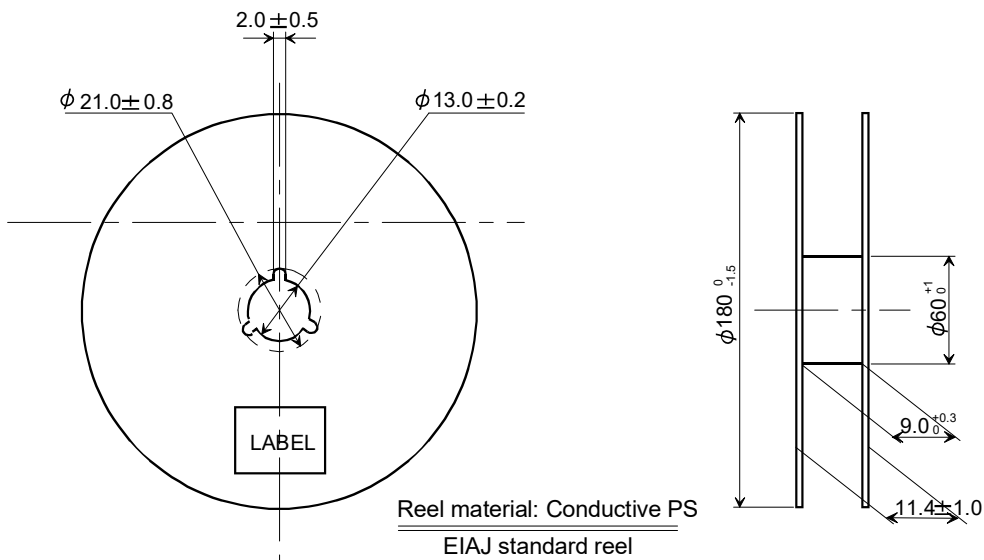
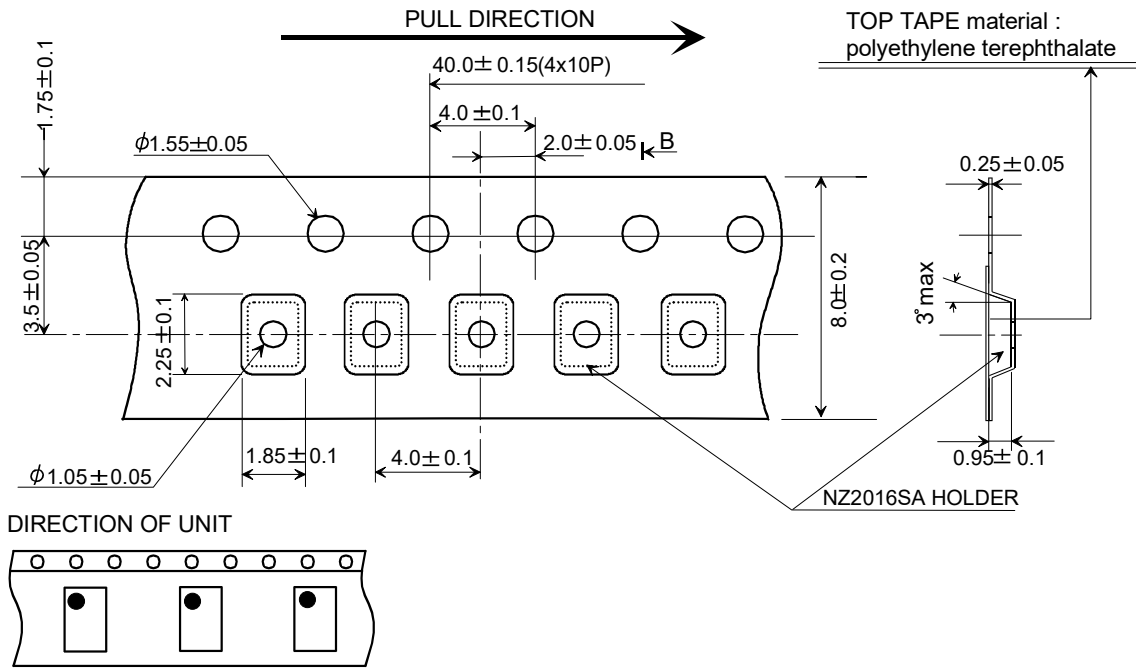

	Date of Revise	Charge	Approved	Reason		
B	7.Dec.2015	C.Sakurai	Y.Akasaka	Title of change(NZ2016SA→NZ2016)		
	Date	Name	Third Angle Projection	Tolerance		
Drawn	18.Jan.2008	S.Murase	Dimension:mm	Scale		
Designed	18.Jan.2008	S.Murase	Title	Drawing No.		
Checked	-----	-----			NZ2016S Taping and Reel Spec.	EKK17B-00076
Approved	18.Jan.2008	Y.Nomura				
				B		