



SPECIFICATION

Customer: _____

Item:	CRYSATL UNIT
Type:	NX3225SA
Customer's Spec. No.:	---
NDK Spec. No.:	W-191-812

Receipt

Charge:

Sales		Tel. 39-02-96702920	Approved	K.Okamoto
Engineer	Eng. Dept. 1st T.Asamizu	Tel. 81-(0)42-900-6631	Checked	---
			Drawn	T.Asamizu

Revision Record				
Rev.	Rev. Date	Items	Contents	Remarks
---	01. Jun. 2006	Issue	---	---

1. Customer's Spec. No. : ---
2. NDK Spec. No. : W-191-812
3. Type : NX3225SA
4. Electrical Characteristics
- 4.1. Nominal Frequency : 26MHz
 - 4.2. Overtone mode : Fundamental
 - 4.3. Adjustment tolerance : +/-10 ppm max (at 25 degC)
 - 4.4. Tolerance Over the Temperature Range : +/-12 ppm max (at -30 to 85 degC)
The reference temperature shall be 25 degC
 - 4.5. Equivalent Series Resistance(Rr) : 40 ohm max
 - 4.6. Shunt Capacitance (C0) : 1.22 pF +/- 0.18 pF
 - 4.7. Motional Capacitance (C1) : 4.92 fF +/- 0.74 fF
 - 4.8. Insulation Resistance : Terminal to terminal insulation resistance must be 500M Ω min. when DC100V+/-10% is supplied.
5. Measurement Circuit
- 5.1. Frequency Measurement
 - Measurement Circuit : PI Circuit
 - Load Capacitance (CL) : 10 pF
 - Level of Drive : 10 uW (100 μ W max.)
 - 5.2. Resistance Measurement
 - Measurement Circuit : PI Circuit
 - Load Capacitance (CL) : Series
 - Level of Drive : 10 uW (100 μ W max.)
6. Other Characteristics
- 6.1. Seal Characteristics : 1.1 x 10⁻⁹ Pa × m³/s max. Helium leak-detector
 - 6.2. Operating Temp. range : - 30 to + 85 degC
 - 6.3. Storage Temperature Range : -40 to + 85 degC
 - 6.2. Aging : +/-1 ppm /year
7. Data Sheet
Data sheets are not presented because above characteristics are guaranteed.
8. Applied Drawing
- 8.1. Dimension of external : EXD14B-00370
 - 8.2. Marking Drawing : EXH11B-00319
 - 8.3. Taping and Reel Drawing : EXK17B-00098
 - 8.4. Reliability guarantee items : EXS30B-00310

9. Notice

- 9.1. Order items are manufactured according to specification. As to conditions, which are not indicated in this specification and unpredictable such as applied condition and oscillation margin, please check them beforehand.
- 9.2. Unless we receive request for modification within 3 weeks from the issue date of this NDK specification sheet, we will supply products according to this specification. Also, if you'd like to modify specification of order, which has been placed with delivery request within 3 weeks from the issue data of this specification sheet, we would like to discuss with you separately.
- 9.3. In no event shall the company be liable for any product failure resulting from an inappropriate handling or operation of the product beyond the scope of its guarantee.
- 9.4. Where any change to the process condition is made due to the change(s) in the production line, inform personnel of the specifications.
- 9.5. Should this specification data give rise to any disputes relating to any intellectual property rights or any other rights of a third person, the company shall not indemnify anyone for any damage. Their disclosure must not be construed as the grant of a license to use any of the intellectual property rights owned by the company.
- 9.6. If you intend to use products listed on this specification for applications that may result in loss of life or assets (controls relating to safety, medical equipment, aeronautical equipment, space equipment, etc.), please do not fail to advise us of your intention beforehand.
- 9.7. In the company's production process whatever amount of ozone depleting substances (ODS) as specified in the Montreal protocol is not used.
- 9.8. Information contained in this specification must not be quoted, reproduced or used for other purposes including processing either in part or in full without obtaining prior approval from the company.

10. Prohibited items

Be sure to use the product under the following conditions. Otherwise, the characteristics deterioration or destruction of the product may result.

(1) Reflow soldering heat resistance

Peak temperature: 265°C, 10 sec

Heating: 230°C or higher, 40 sec

Preheating: 150°C to 180°C, 120 sec

Reflow passage times: twice

(2) Manual soldering heat resistance

Pressing a soldering iron of 400°C on the terminal electrode for four seconds (twice).

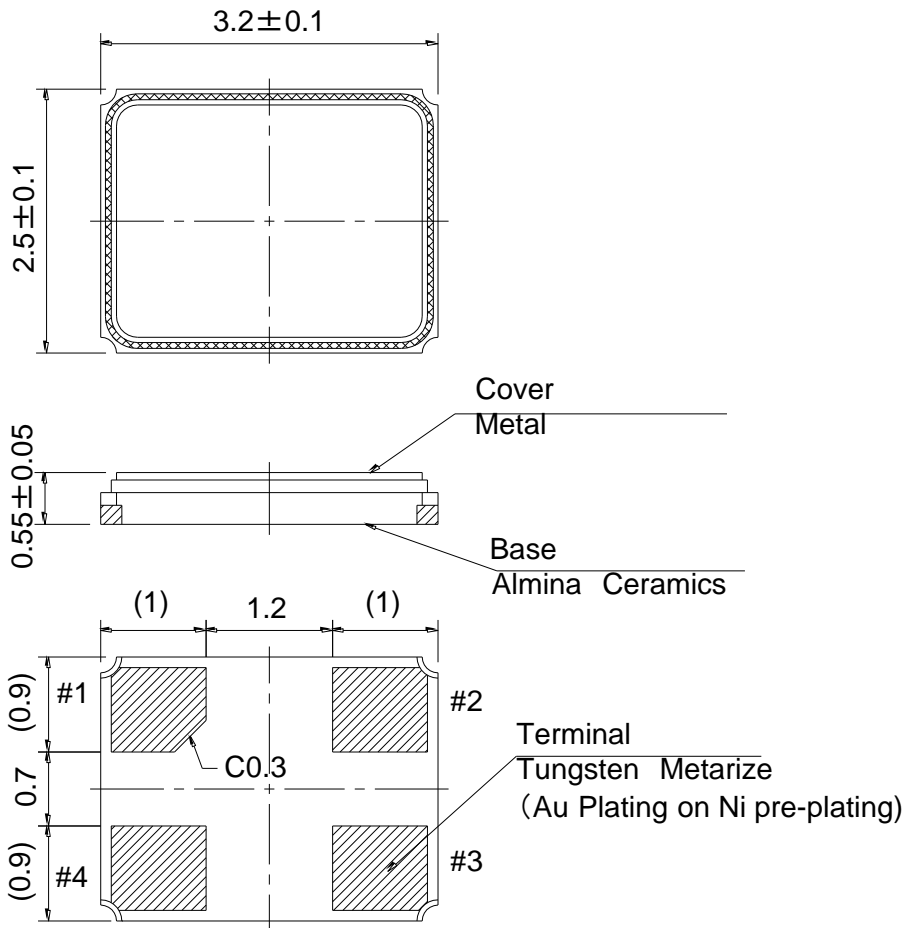

LAND PATTERN (TYPICAL)

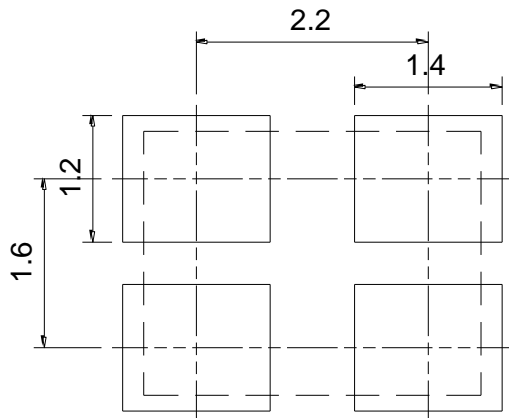

PIN CONNECTION (TOP VIEW)

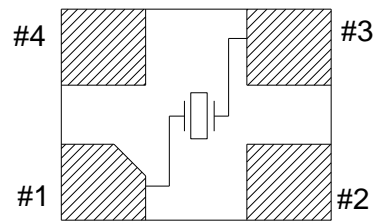

※ #1,#3 : Xtal
#2,#4 : GND (CONNECTION COVER)

	Date of Revise	Charge	Approved	Reason
	Date	Name	Third Angle Projection	Tolerance
Drawn	25.Oct.2005	S.Mizusawa	Dimension:mm	---
Designed	25.Oct.2005	S.Mizusawa	Title	Drawing No.
Checked			NX3225SA Dimension Drawing	EXD14B-00370
Approved	25.Oct.2005	S.Mizusawa		

NIHON DEMPA KOGYO CO., LTD.

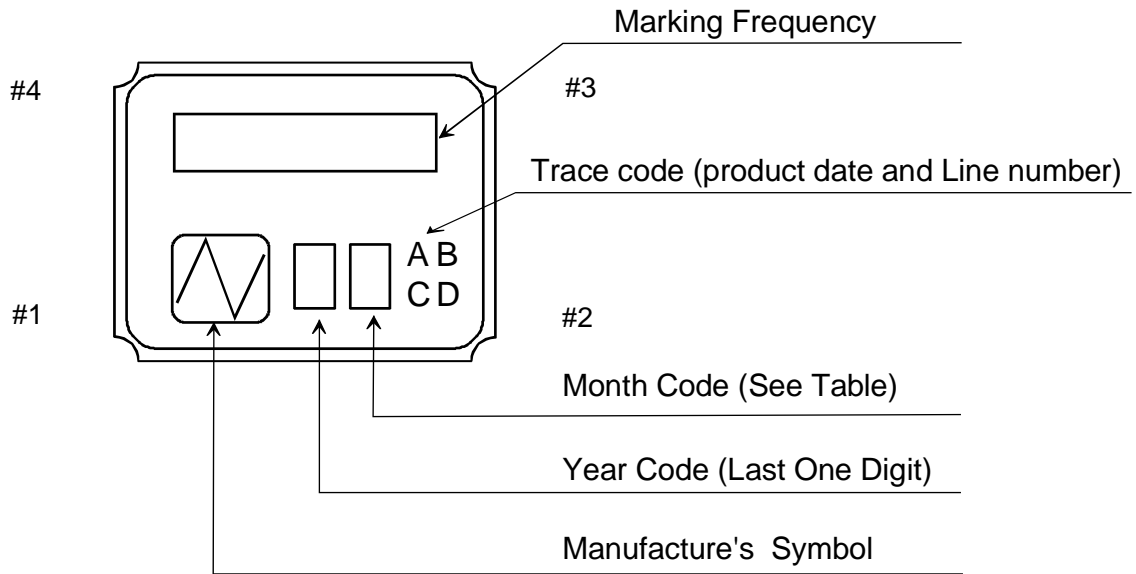

NOTE

1. Month Code Table

Month	1 Jan.	2 Feb.	3 Mar.	4 Apr.	5 May.	6 Jun.	7 Jul.	8 Aug.	9 Sep.	10 Oct.	11 Nov.	12 Dec.
Month Code	1	2	3	4	5	6	7	8	9	X	Y	Z

*Marking digits are not include a decimal point and dot mark.

We will apply trace code sequentially since Apr. 2006.

But please understand that there is a case without trace code indication in early period of introduction.

	Date of Revise	Charge	Approved	Reason			
A							
	Date	Name	Third Angle Projection	Tolerance	Scale		
Drawn	14. Feb. 2006	T.Asamizu	Dimension:mm		/		
Designed	14. Feb. 2006	T.Asamizu	Title Crystal Holder Marking		Drawing No. EXH11B-00319		
Checked	14. Feb. 2006	I.Miyahara					Rev.
Approved	14. Feb. 2006	K.Okamoto					

NIHON DEMPA KOGYO CO., LTD.

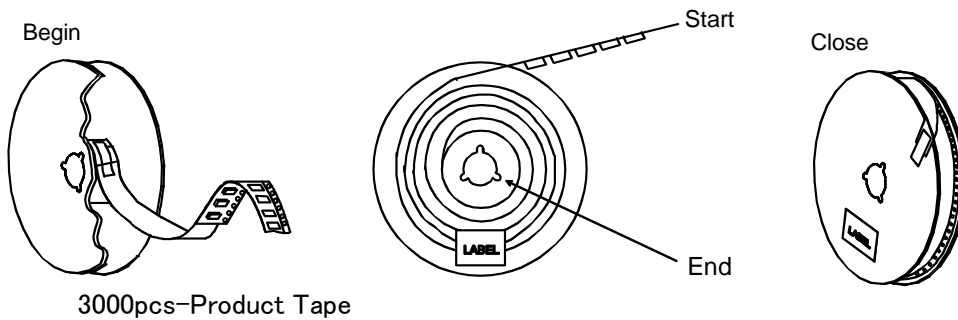
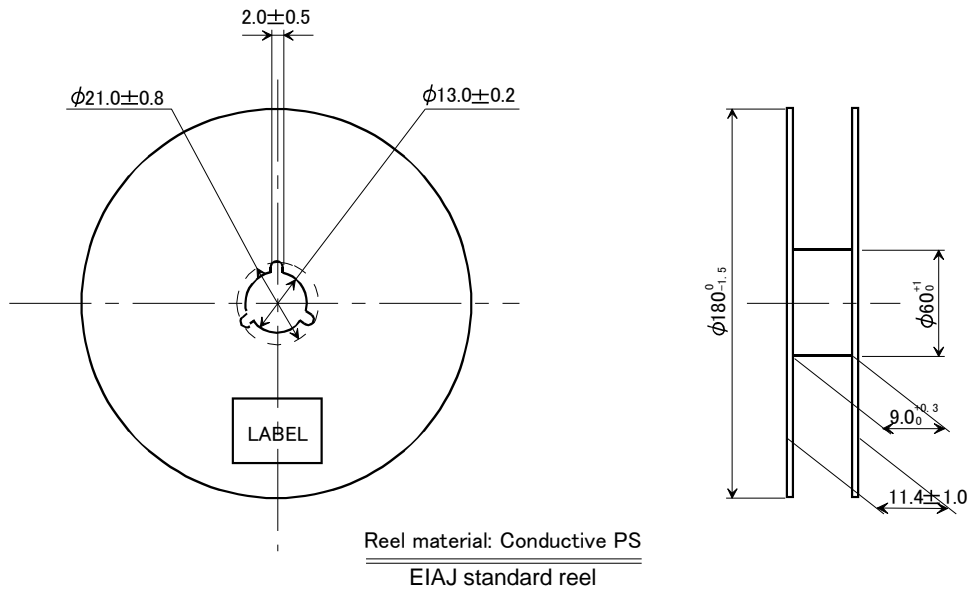
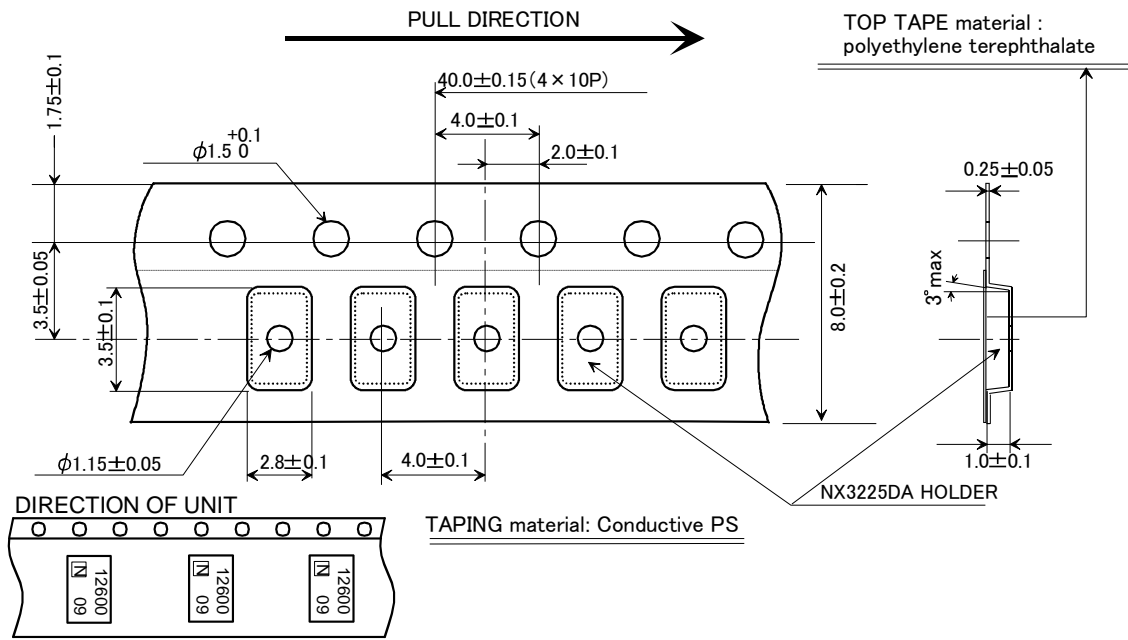

	Date of Revise	Charge	Approved	Reason	
D	8.May.2003	S.Sunaba	S.Mizusawa	TOP TAPE peeling strength of cover tape deletion.	
	Date	Name	Third Angle Projection	Tolerance	
Drawn	3.Sep.2001	K.Oguri	Dimension:mm	Scale	
Designed	3.Sep.2001	K.Oguri	Title	Drawing No.	
Checked					EXK17B-00098
Approved	3.Sep.2001	K.Miyashita			
			NX3225DA Taping and Reel Spec.	D	

NIHON DEMPA KOGYO CO., LTD.

Reliability assurance item

(page: 1/2)

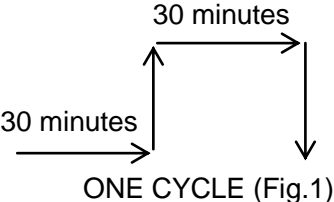
No.	Test Item	Test Methods	Specification Code
1	AGING	1 year at 25 °C +/- 3°C	a
2	COLD RESISTANCE	at -40 °C for 500 hours.	a
3	HUMIDITY	at +85 °C with 80 to 85 % RH for 500 hours.	a
4	THERMAL SHOCK	Temperature cycle as shown in (Fig.1) for 100 cycle. 	a
5	VIBRATION	Frequency Range : 10 to 2000Hz Amplitude or Acceleration : 1.52 mm or 20 G 1 cycle : 20 minutes Test time : Three mutually perpendicular axes each 12 times.	a
6	SHOCK 1	Shock : 3000 Gs 0.3 msec. Test time : Six mutually perpendicular axes each 1 times.	a
7	SHOCK 2	Shock : Device are put on the weight of 200 g and dropped on concrete board. Height : 1.5 m Drop times : Six mutually perpendicular axes each 10 times.	a
8	SOLDERABILITY	Residual heat temperature 150 °C Residual heat time 60 to 120 sec Peak temperature 240°C (more than 215 °C 10 to 30 sec)	b
9	REFLOW RESISTANCE	Temperature cycle as shown in (Fig2.) for 3 cycle.	a

Specification code	Specification
a	dF/F ≤ +/- 1.0ppm dCI ≤ +/- 15% or +/- 2 ohm greater value
b	The electrodes shall acquire a new solder coat over at least 90 % of immersed area.

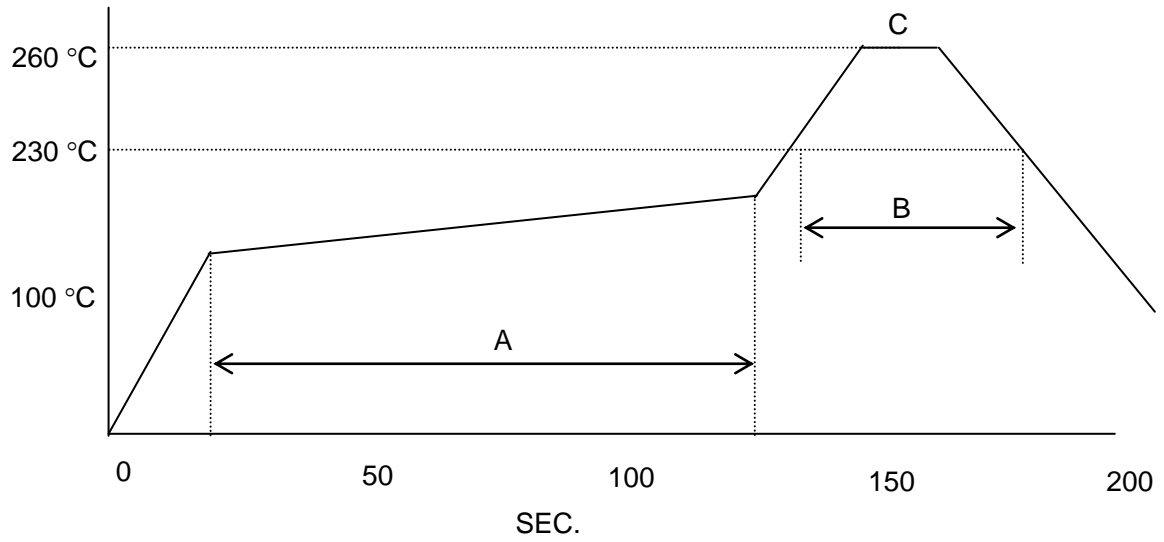

Fig.2 REFLOW

- A: 150 to 180 °C (60 to 120 sec.)
- B: 230 °C min. (30 sec. max.)
- C: PEAK-TEMP. 260 °C +/- 5 °C (10sec. max.)