



# SPECIFICATION

Customer: \_\_\_\_\_

Item: Crystal Unit

---

Type: NX3225SA

---

Nominal Frequency: 24.000 MHz

---

Customer's Spec. No.: ---

---

NDK Spec. No.: EXS00A-CS11370

---

Receipt
---------

Revision Record						
Rev.	Date	Items	Contents	Approved	Checked	Drawn
---	21.Dec.2017	Issue	---	I.Miyahara	---	K.Tsukumo

1. Customer's Spec. No. :  
 2. NDK Spec. No. : EXS00A-CS11370  
 3. Type : NX3225SA

## 4. Electrical Specifications

	Parameters	SYM.	Electrical Spec.				Notes
			min	typ	Max	Units	
1	Nominal frequency	$f_{nom}$	24.000			MHz	
2	Overtone order	-	Fundamental			-	
3	Frequency tolerance	-	-15	-	+15	$\times 10^{-6}$	at +25°C
4	Frequency versus temperature characteristics	-	-20	-	+20	$\times 10^{-6}$	at -40~+85°C The reference temperature shall be +25°C
5	Load capacitance	$C_L$	-	18	-	pF	IEC $\pi$ -Network
6	Equivalent resistance	$R_S$	-	-	50	$\Omega$	IEC $\pi$ -Network Series
7	Level of drive	-	-	10	200	$\mu$ W	
8	Insulation resistance	-	500	-	-	M $\Omega$	When terminal to terminal and terminal to cover were applied at DC100V $\pm$ 15V.
9	Operating temperature range	$T_{opr}$	-40	-	+85	°C	
10	Storage temperature range	$T_{str}$	-40	-	+85	°C	
11	Air-tightness	-	-	-	$1.1 \times 10^{-9}$	Pa m <sup>3</sup> /s	Helium leak detector

## 5. Examination results document

Since a performance is guaranteed, an examination results document does not submit.

## 6. Application drawing

- 6.1 External dimension : EXD14B-00370  
 6.2 Taping and reel figure : EXK17B-00098, EXK17B-00415  
 6.3 Reel Packing : EEK17B-00015, EEK17B-00012  
 6.4 Holder marking : EXH11B-00317  
 6.5 Reliability assurance Item : EXS30B-00249

## 7. Notice

- 7.1 Crystal units will be damaged by ultrasonic welding process due to resonance of crystal wafer itself. NDK does not recommend using ultrasonic welding. If Ultra Sonic welding used, there are products that resonance phenomenon hardly occurs so please confirm with our sales.
- 7.2 Order items are manufactured according to specification. As to conditions, which are not indicated in this specification and unpredictable such as applied condition and oscillation margin, please check them beforehand.
- 7.3 Unless we receive request for modification within 3 weeks from the issue date of this NDK specification sheet, we will supply products according to this specification. Also, if you'd like to modify specification of order, which has been placed with delivery request within 3 weeks from the issue data of this specification sheet, we would like to discuss with you separately.
- 7.4 In no event shall the company be liable for any product failure resulting from an inappropriate handling or operation of the product beyond the scope of its guarantee.
- 7.5 Where any change to the process condition is made due to the change(s) in the production line, inform personnel of the specifications.
- 7.6 Should this specification data give rise to any disputes relating to any intellectual property rights or any other rights of a third person, the company shall not indemnify anyone for any damage. Their disclosure must not be construed as the grant of a license to use any of the intellectual property rights owned by the company.
- 7.7 If you intend to use products listed on this specification for applications that may result in loss of life or assets (controls relating to safety, medical equipment, aeronautical equipment, space equipment, etc.), please do not fail to advise us of your intention beforehand.
- 7.8 In the company's production process whatever amount of ozone depleting substances (ODS) as specified in the Montreal protocol is not used.
- 7.9 Information contained in this specification must not be quoted, reproduced or used for other purposes including processing either in part or in full without obtaining prior approval from the company.
- 7.10 Crystal units will be damaged by ultrasonic welding process due to resonance of crystal wafer itself. NDK does not recommend using ultrasonic welding. If Ultra Sonic welding used, NDK strongly recommend verifying crystal unit damage by ultrasonic weld.
- 7.11 The appearance color and so on have a different case by purchasing it more than 2 suppliers of the component, but characteristic and reliability are guaranteed.
- 7.12 In case of the product long time keep at high temperature and humidity, may affect product characteristic (solder ability) and a packing condition.  
Please keep at storage condition of temperature +5°C ~+35°C, humidity ~85%RH.

## 8. Prohibited items

Be sure to use the product under the following conditions. Otherwise, the characteristics deterioration or destruction of the product may result.

- (1) Reflow soldering heat resistance
  - Peak temperature: 265°C, 10 sec
  - Heating: 230°C or higher, 40 sec
  - Preheating: 150°C to 180°C, 120 sec
  - Reflow passage times: twice
- (2) Manual soldering heat resistance
  - Pressing a soldering iron of 400°C on the terminal electrode for four seconds (twice).

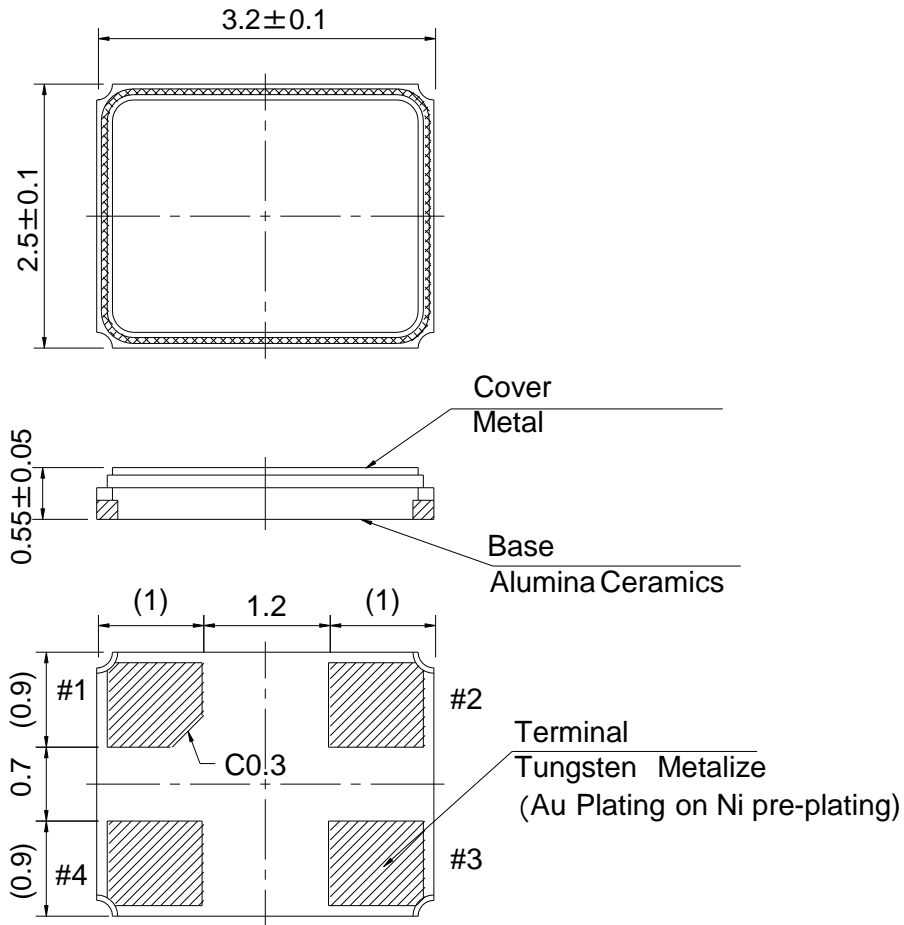

LAND PATTERN (TYPICAL)

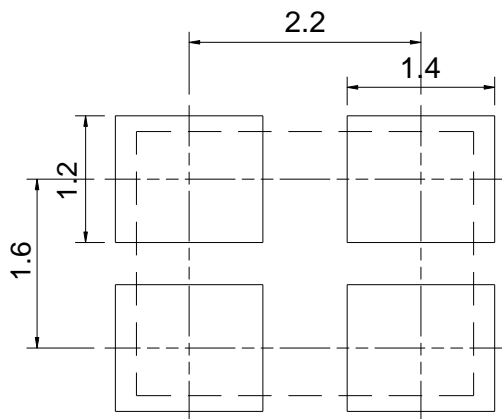

PIN CONNECTION (TOP VIEW)

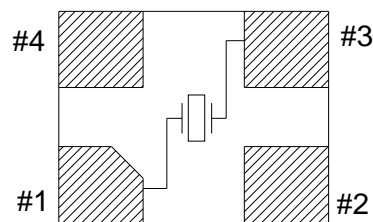

※ #1,#3 : Xtal  
#2,#4 : GND (CONNECTION COVER)

	Date of Revise	Charge	Approved	Reason	
A	4.Sep.2007	R.Shariman	K.Kubota	Add Tolerance.	
	Date	Name	Third Angle Projection	Tolerance	Scale
Drawn	25.Oct.2005	S.Mizusawa	Dimension:mm	±0.1	- / -
Designed	25.Oct.2005	S.Mizusawa	Title	Drawing No.	Rev.
Checked					
Approved	25.Oct.2005	S.Mizusawa			
			<b>NX3225SA</b> Dimension Drawing	<b>EXD14B-00370</b>	<b>A</b>

NIHON DEMPA KOGYO CO., LTD.

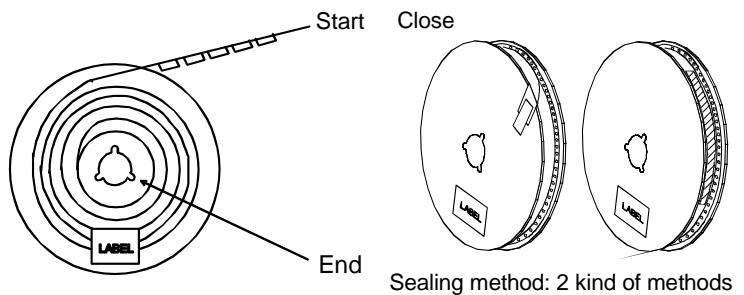
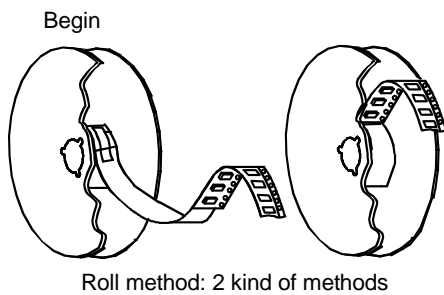
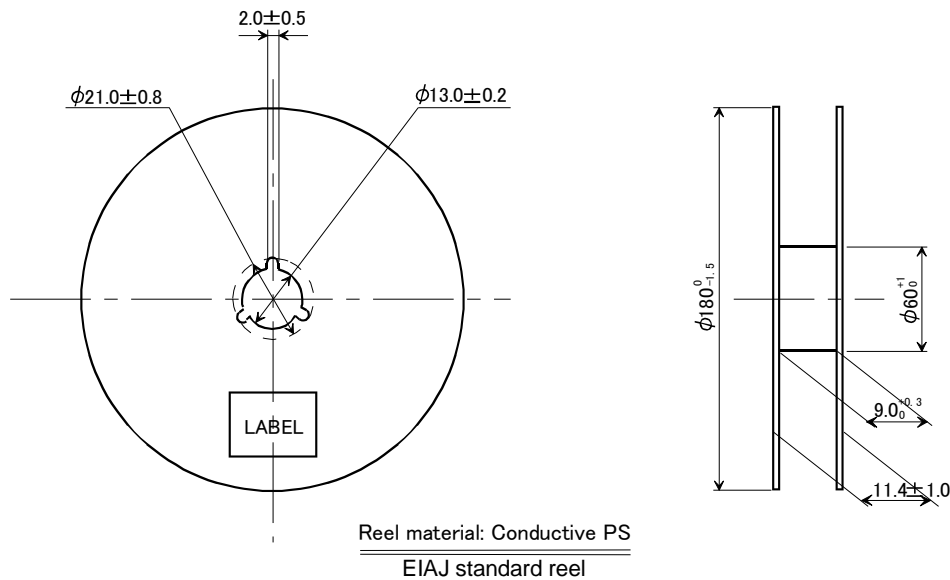
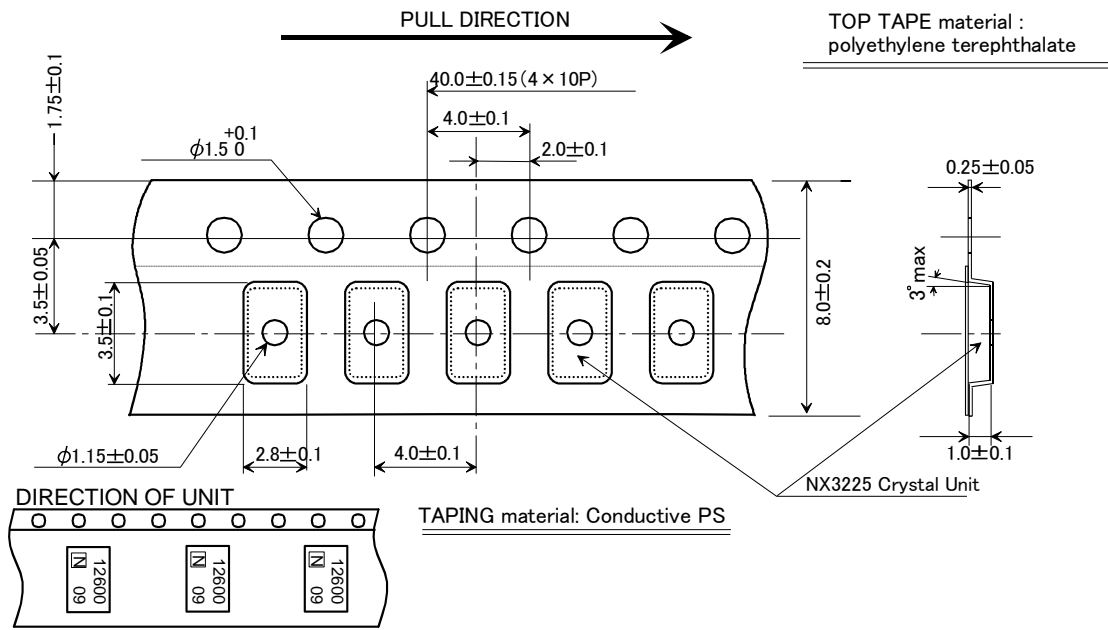

3000pcs-Product Tape

	Date of Revise	Charge	Approved	Reason
I	22 Aug. 2012	T. Shimizu	K. Oguri	Top cover tape leader line was deleted.
	Date	Name	Third Angle Projection	Tolerance
Drawn	3.Sep.2001	K.Oguri	Dimension:mm	Scale
Designed	3.Sep.2001	K.Oguri	Title	Drawing No.
Checked			NX3225 Series Taping and Reel Spec.	EXK17B-00098
Approved	3.Sep.2001	K.Miyashita		
				I

NIHON DEMPA KOGYO CO., LTD.

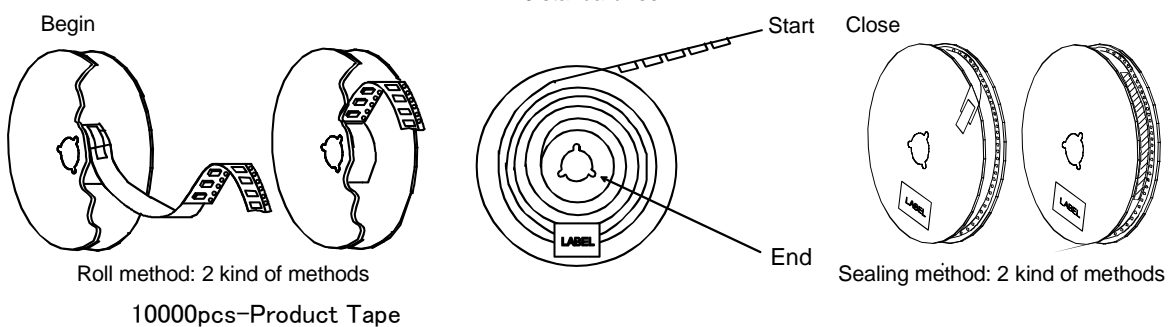
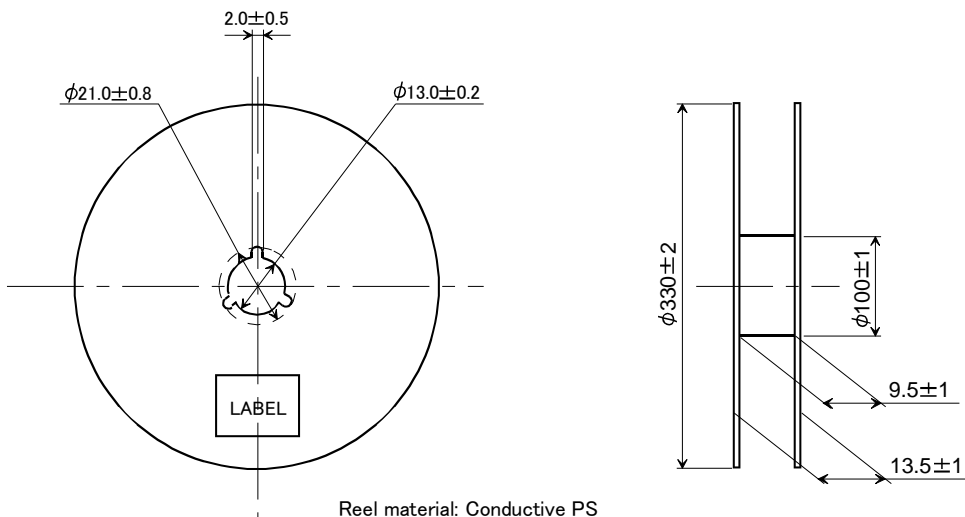
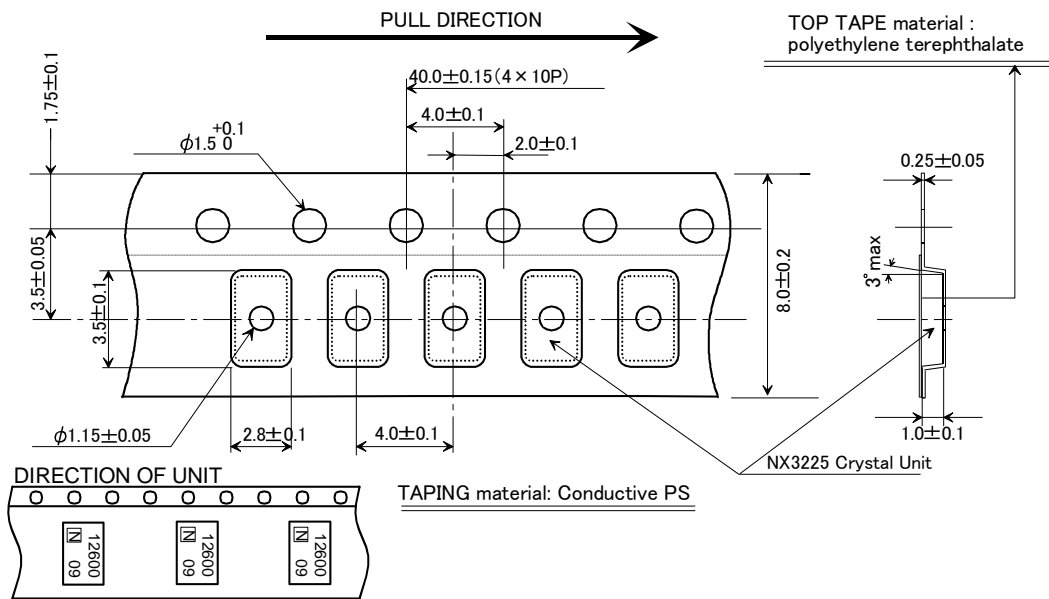

	Date of Revise	Charge	Approved	Reason
	Date	Name	Third Angle Projection	Tolerance
Drawn	29 Sep. 2016	H. Ohkubo	Dimension:mm	Scale
Designed	29 Sep. 2016	H. Ohkubo	Title	Rev.
Checked	---	---	NX3225 Series Taping and Reel Spec.	EXK17B-00415
Approved	29 Sep. 2016	H. Ohkubo		

**NIHON DEMPA KOGYO CO., LTD.**

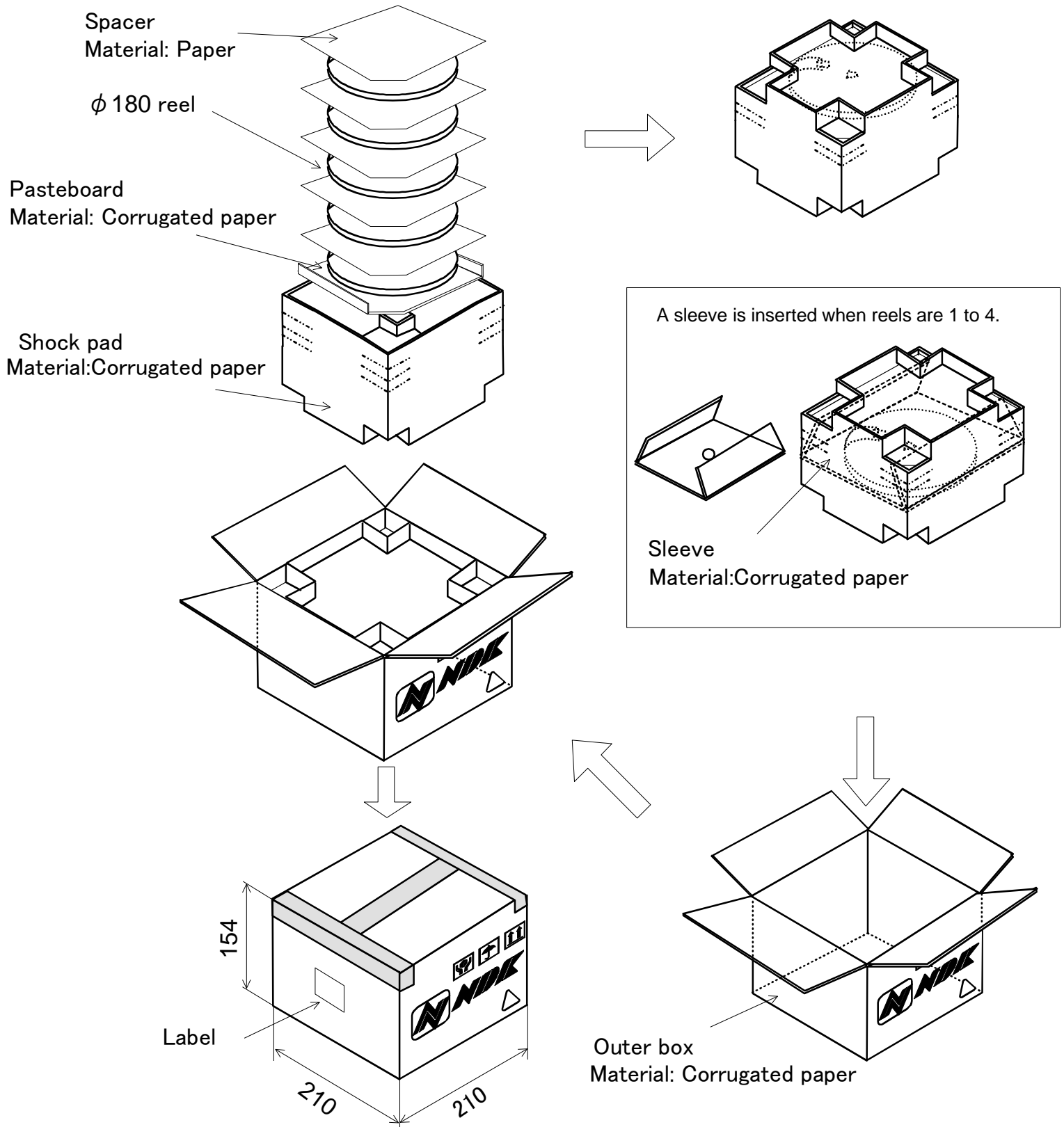

	Date of Revise	Charge	Approved	Reason	
C	4 Jul. 2012	H.Ohkubo	K.Oguri	Addition of condition when reels are 1 to 4.	
	Date	Name	Third Angle Projection	Tolerance	Scale
Drawn	26 Feb. 2010	H. Ohkubo	Dimension:mm	-----	-----
Designed	26 Feb. 2010	K.Oguri	Title <b>180 dia. Reel package</b>	Drawing No. <b>EEK17B-00015</b>	Rev.
Checked	26 Feb. 2010	K.Oguri			C
Approved	26 Feb. 2010	J. Nakamura			

**NIHON DEMPA KOGYO CO., LTD.**

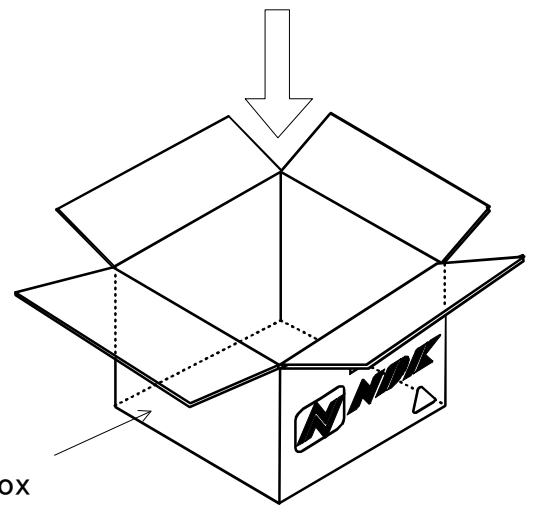
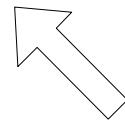
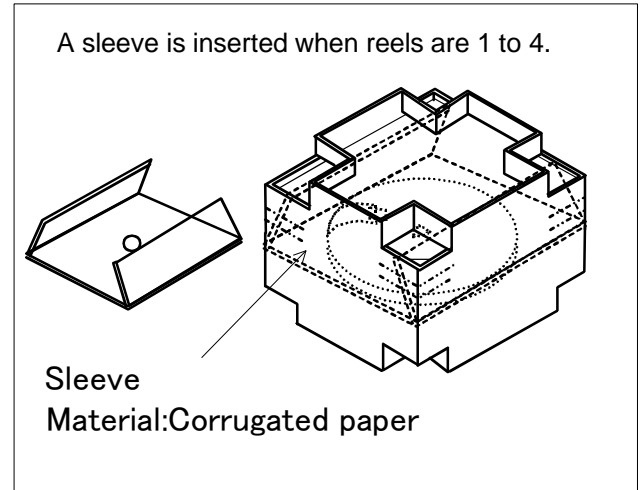
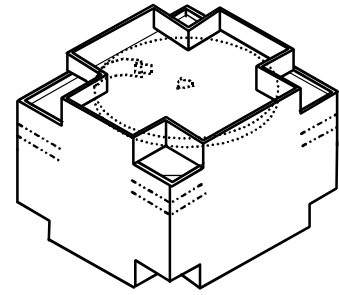
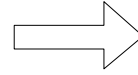
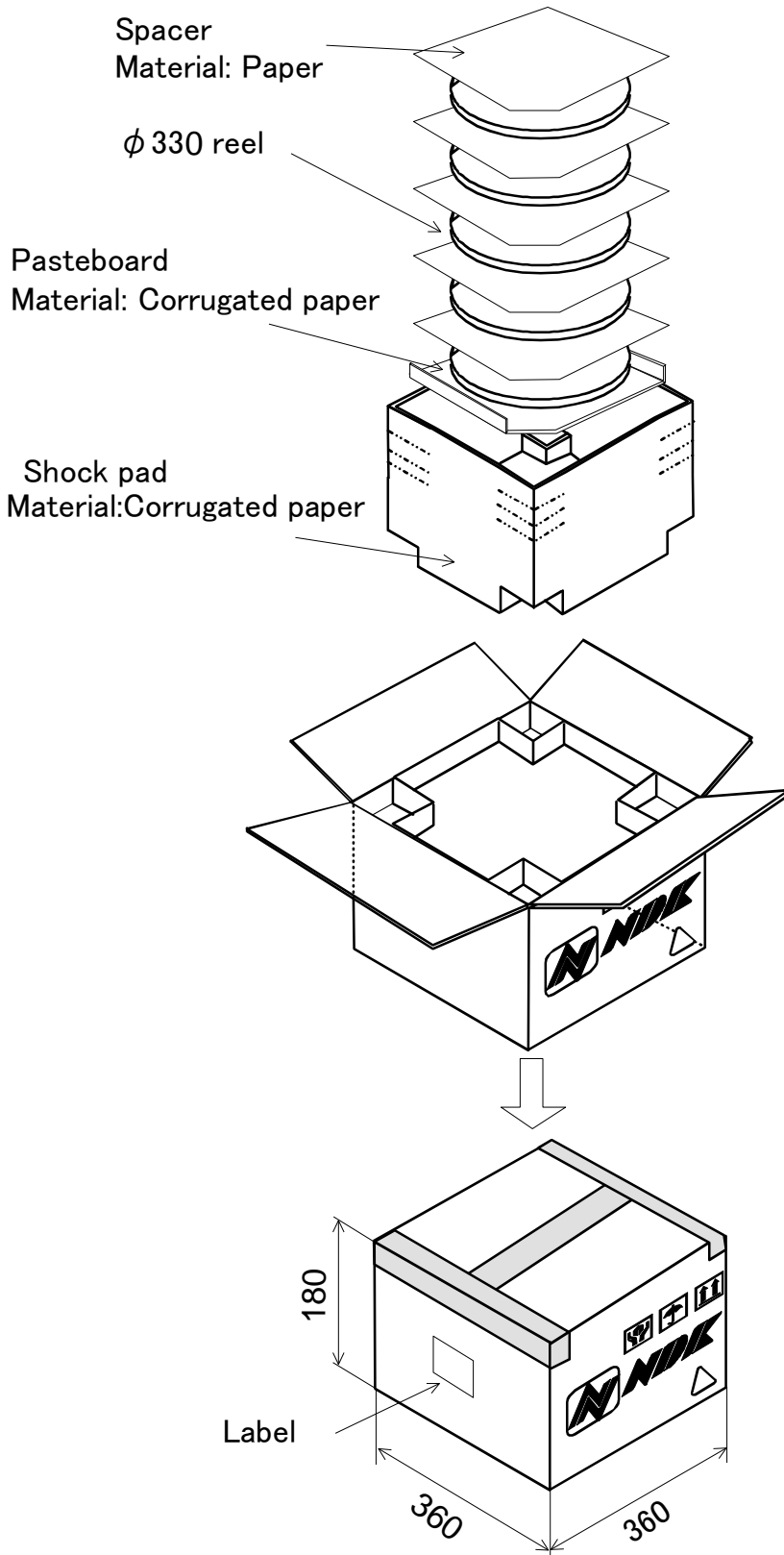

	Date of Revise	Charge	Approved	Reason	
B	18 Nov. 2016	H. Ohkubo	H. Murakoshi	Addition of condition when reels are 1 to 4.	
	Date	Name	Third Angle Projection	Tolerance	Scale
Drawn	26 Feb. 2010	H. Ohkubo	Dimension:mm	-----	-----
Designed	26 Feb. 2010	K. Oguri	Title <b>330 dia. Reel package</b>		Drawing No. <b>EEK17B-00012</b>
Checked	26 Feb. 2010	K. Oguri			
Approved	26 Feb. 2010	J. Nakamura			

**NIHON DEMPA KOGYO CO., LTD.**

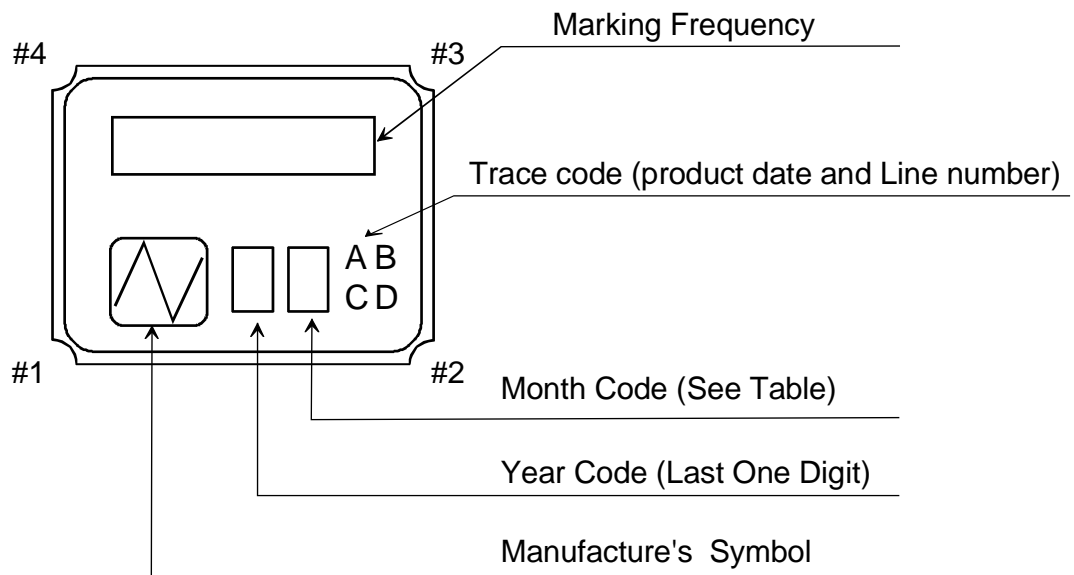

**NOTE**

**1. Frequency Code**

Marking Frequency is consist of five digits, first five digits of Nominal Frequency

Example

Nominal Frequency	28.636363 MHz
Frequency Code	28.636

**2. Month Code Table**

Month	1 Jan.	2 Feb.	3 Mar.	4 Apr.	5 May.	6 Jun.	7 Jul.	8 Aug.	9 Sep.	10 Oct.	11 Nov.	12 Dec.
Month Code	1	2	3	4	5	6	7	8	9	X	Y	Z

\*Marking digits are not include a decimal point and dot mark.

	Date of Revise	Charge	Approved	Reason		
D	10. Dec 2014	Y.Sakurai	H.Kobayashi	Added terminal number information.		
	Date	Name	Third Angle Projection	Tolerance	Scale	
Drawn	16.Jan.2006	I.Miyahara	Dimension:mm		/	
Designed	16.Jan.2006	I.Miyahara	Title		Drawing No.	Rev.
Checked	16.Jan.2006	---	<b>Crystal Holder Marking</b>		<b>EXH11B-00317</b>	<b>D</b>
Approved	16.Jan.2006	K.Okamoto				

**NIHON DEMPA KOGYO CO., LTD.**

**Reliability assurance item**

(page: 1/1)

No.	Test Item	Test Methods	Specification Code
1	High Temperature Storage *1	+85±3°C 720h	A
2	Low Temperature Storage	-40±3°C 500h	A
3	Temperature Humidity	+60±3°C 90~95%RH 500h	A
4	Temperature Cycling *1	-40±3°C / +85±3°C It is 500 cycles using 30 minutes each as 1 cycle.	A
5	Vibration	Frequency Range : 10~55Hz Amplitude : 1.52mm 1 cycle : 1 minutes Test time : Three mutually perpendicular axes each 2 hours.	A
6	Shock	Devices are shocked to half sine wave (981m/s <sup>2</sup> ) three mutually perpendicular axis each 3 times.	A
7	Drop	Devices are dropped from the height 75cm onto wooden block. ( more than 30mm thickness.) Execution 3 times random drops	A
8	Solderability	Pre-heat temperature : +150±10°C Pre-heat time : 60~120s When the temperature of the specimen is reached at +215±3°C, it shall be left for 30±1sec. Peak temperature 240±5°C Material: Pb-free (Sn-3.0Ag-0.5Cu) Flux : Rosin resin methyl alcohol solvent ( 1 : 4 )	B
9	Reflow resistance	Pre-heat temperature : +150~180°C Pre-heat time : 90±30s Heat temperature : more than +230°C Heat time : 30s±10s Peak temperature : +260±5°C Peak time : less than 10s	A

**\*1. High Temperature Storage and Temperature Cycling**

In case of customer spec on High temperature exceed +85°C, Low temperature exceed -40°C, above test according to customer spec high or low temperature will be perform and guarantee.

Specification code	Specification
A	$\Delta f/f \leq \pm 5$ ppm $\Delta Cl/Cl \leq \pm 15$ % or 5 $\Omega$ make use larger value
B	The electrodes should be covered by a new solder at least 90% of immersed area.