



RoHS Compliant
Directive 2011/65/EU

SPECIFICATION

Customer: ELTECH

Item:	Crystal Unit
Type:	NX3225HA
Nominal Frequency:	24 MHz
Customer's Spec. No.:	---
NDK Spec. No.:	NX3225HA-24MHz
	S1-4085-3020-12

Receipt

Charge:

Sales	NDK-I Paola Bandera	Tel.: 39-02-96702920 e-Mail: bandera@it.ndk.com
Engineer	Engineering Dept.1 Omomo	Tel.: 81-4-2900-6631 e-Mail: ohmomo@ndk.com

Revision Record						
Rev.	Date	Items	Contents	Approved	Checked	Drawn
---	20.Jun.2014	Issue	---	H.Kobayashi	M.Sato	R.Omomo

1. Customer's Spec. No. : ---
2. NDK Spec. No. : EXS03A-45941
3. Type : NX3225HA
4. Electrical Specifications

	Parameters	SYM.	Electrical Spec.				Notes
			MIN	TYP	MAX	UNITS	
1	Nominal frequency	f_{nom}	24			MHz	
2	Overtone order	-	Fundamental			-	
3	Frequency tolerance	-	-20	-	+20	ppm	at +25°C
4	Frequency versus temperature characteristics	-	-30	-	+30	ppm	at -40~+85 °C The reference temperature shall be 25°C
5	Equivalent resistance	R_r	-	-	80	Ω	IEC π -network / Series
6	Load capacitance	C_L	-	12	-	pF	IEC π -network
7	Level of drive	-	-	10	200	μ W	
8	Insulation resistance	-	500	-	-	M Ω	Terminal to terminal insulation resistance must be 500M Ω (min) when DC100V \pm 15V is applied.
9	Storage temperature range	-	-40	-	+85	°C	

5. Examination results document

Since a performance is guaranteed, an examination results document does not submit.

6. Application drawing

- 6.1 External dimension : EXD14B-00469
- 6.2 Structural Drawing : EXD13B-00217
- 6.3 Taping and reel figure : EXK17B-00247
- 6.4 Reel Packing : EEK17B-00015
- 6.5 Holder marking : EXH11B-00457
- 6.6 Reliability assurance item : EXS30B-00788
- 6.7 Reflow Condition : EXS30B-00344

7. Notice

- 7.1 Order items are manufactured according to specification. As to conditions, which are not indicated in this specification and unpredictable such as applied condition and oscillation margin, please check them beforehand.
- 7.2 Unless we receive request for modification within 3 weeks from the issue date of this NDK specification sheet, we will supply products according to this specification. Also, if you'd like to modify specification of order, which has been placed with delivery request within 3 weeks from the issue data of this specification sheet, we would like to discuss with you separately.
- 7.3 In no event shall the company be liable for any product failure resulting from an inappropriate handling or operation of the product beyond the scope of its guarantee.
- 7.4 Where any change to the process condition is made due to the change(s) in the production line, inform personnel of the specifications.
- 7.5 Should this specification data give rise to any disputes relating to any intellectual property rights or any other rights of a third person, the company shall not indemnify anyone for any damage. Their disclosure must not be construed as the grant of a license to use any of the intellectual property rights owned by the company.
- 7.6 If you intend to use products listed on this specification for applications that may result in loss of life or assets (controls relating to safety, medical equipment, aeronautical equipment, space equipment, etc.), please do not fail to advise us of your intention beforehand.
- 7.7 In the company's production process whatever amount of ozone depleting substances (ODS) as specified in the Montreal protocol is not used.
- 7.8 Information contained in this specification must not be quoted, reproduced or used for other purposes including processing either in part or in full without obtaining prior approval from the company.
- 7.9 Crystal units will be damaged by ultrasonic welding process due to resonance of crystal wafer itself. NDK does not recommend using ultrasonic welding. If Ultra Sonic welding used, NDK strongly recommend verifying crystal unit damage by ultrasonic weld.
- 7.10 The appearance color has a different case by purchasing it more than 2 suppliers of the component, but characteristic and reliability are guaranteed.

8. Prohibited items

Be sure to use the product under the following conditions. Otherwise, the characteristics deterioration or destruction of the product may result.

- 8.1 Please mount the components on a circuit board by re-flow soldering. Soldering with soldering iron is not acceptable.
- 8.2 Reuse of the components once mounted a circuit board is not acceptable.
- 8.3 Solder to be used is recommended the following.
(Used solder condition)
Solder composition : Sn-3.0Ag-0.5Cu
Standard thickness of solder : 0.10 to 0.15mm
- 8.4 Be sure to use the product under the following conditions. Otherwise, the characteristics deterioration or destruction of the product may result.
(Reflow soldering heat resistance)
Peak temperature: 265°C, 10 sec
Heating: 230°C or higher, 40 sec
Preheating: 150°C to 180°C, 120 sec
Reflow passage times: twice

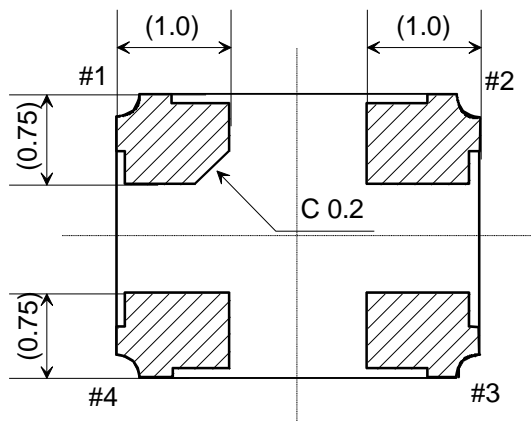
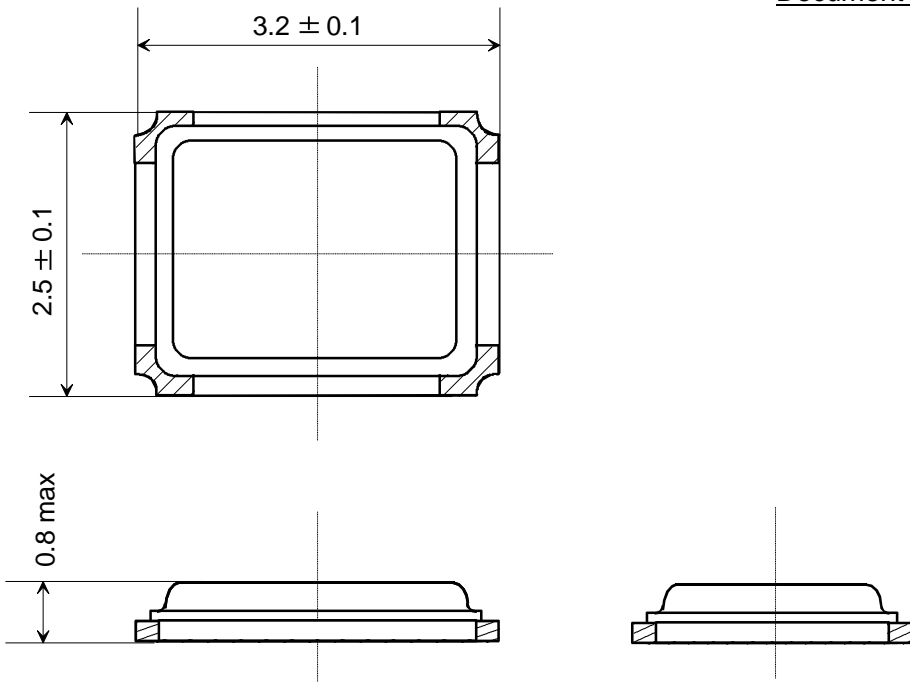

LAND PATTERN (TYPICAL)

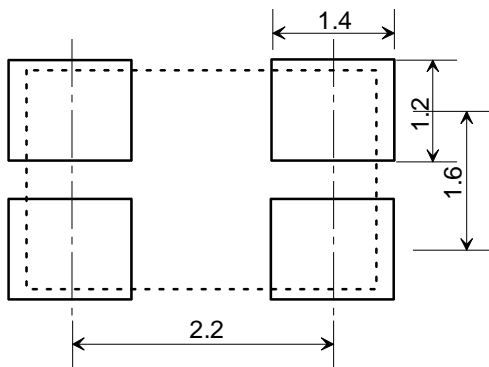

TOP VIEW
PIN CONNECTION

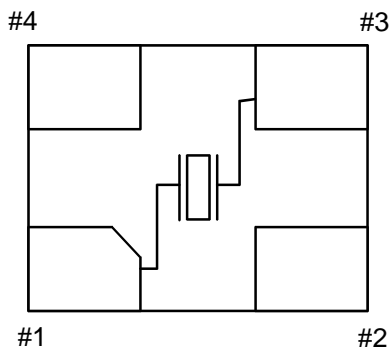

TERMINAL
#1,#3:X'tal
#2,#4:No Connection

Date of Revise	Charge	Approved	Reason		
Drawn	Date 8.Dec.2009	Name M.Sato	Third Angle Projection Dimension:mm	Tolerance ---	Scale - / -
Designed	8.Dec.2009	M.Sato	Title NX3225HA Dimension Drawing	Drawing No. EXD14B-00469	Rev.
Checked	8.Dec.2009	---			
Approved	8.Dec.2009	K.Ueki			

NIHON DEMPA KOGYO CO., LTD.

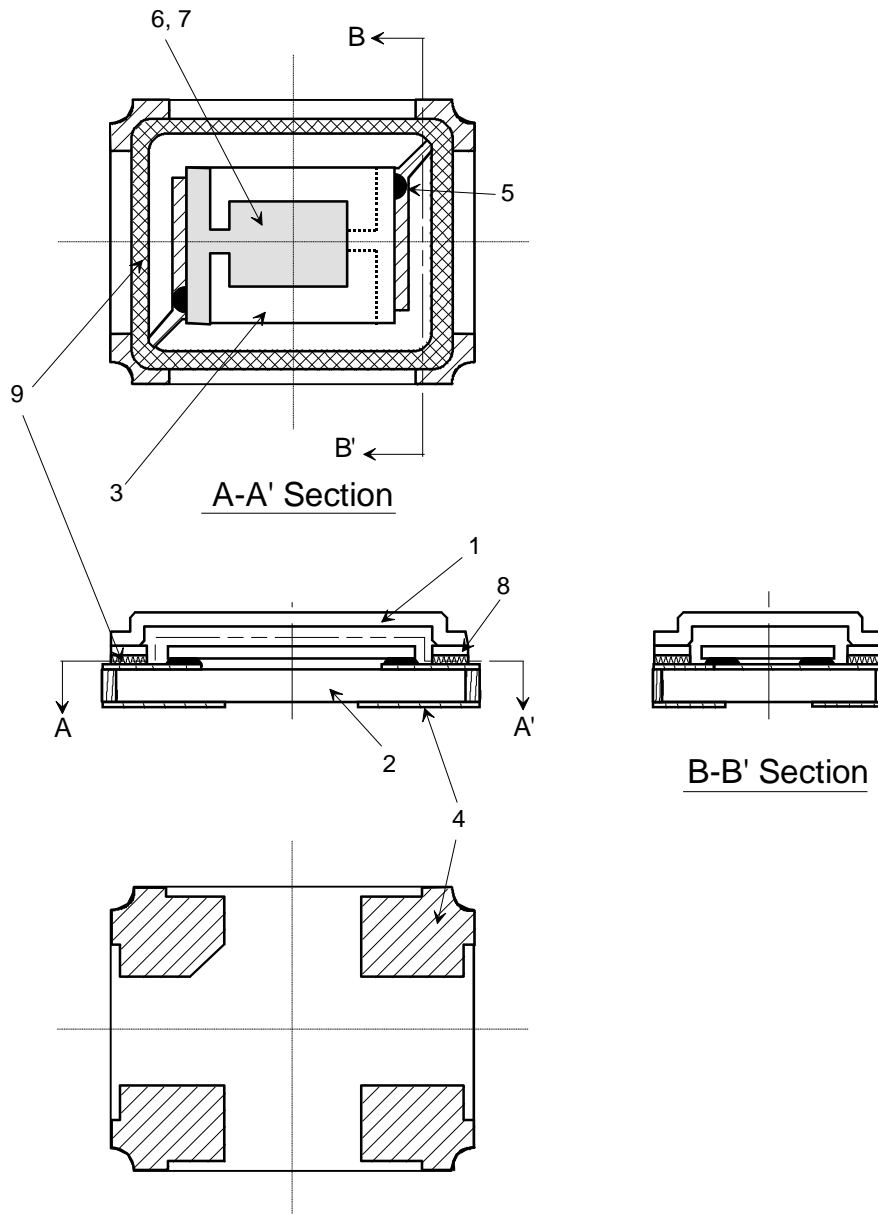

Seal		Resin sealing		Mass (Reference)		0.013g
No.	Material	Notes	No.	Material	Notes	
1	Metal	---	8	Resin	Epoxy Resin	
2	Ceramics	Color White	9	Glass	---	
3	Crystal (SiO ₂)	Crystal Wafer	10			
4	Terminal	AgPd	11			
5	Conductive adhesive	Silicone	12			
6	Ag	Form is example	13			
7	Cr	Form is example	14			

	Date of Revise	Charge	Approved	Reason	
A	31.Aug.2010	Y.Ikeda	K.Ueki	Correction of errors	
	Date	Name	Third Angle Projection	Tolerance	Scale
Drawn	14. Jul. 2010	Y.Ikeda	Unit :mm	----	- / -
Designed	14. Jul. 2010	M.Sato	Title NX3225HA Structural Drawing	Drawing No. EXD13B-00217	Revision
Checked	14. Jul. 2010	M.Sato			A
Approved	14. Jul. 2010	K.Ueki			

NIHON DEMPA KOGYO CO., LTD.

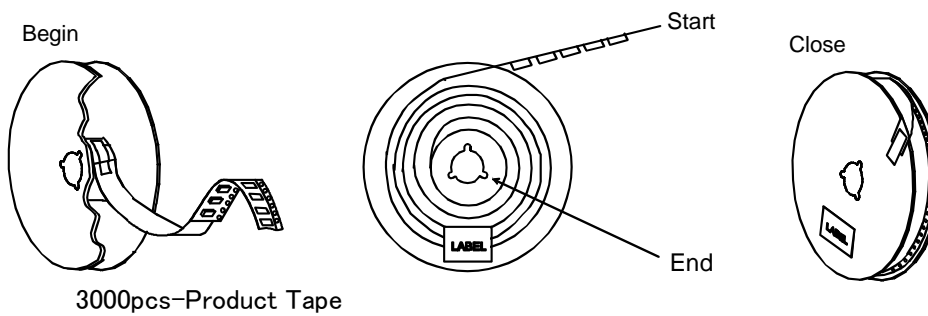
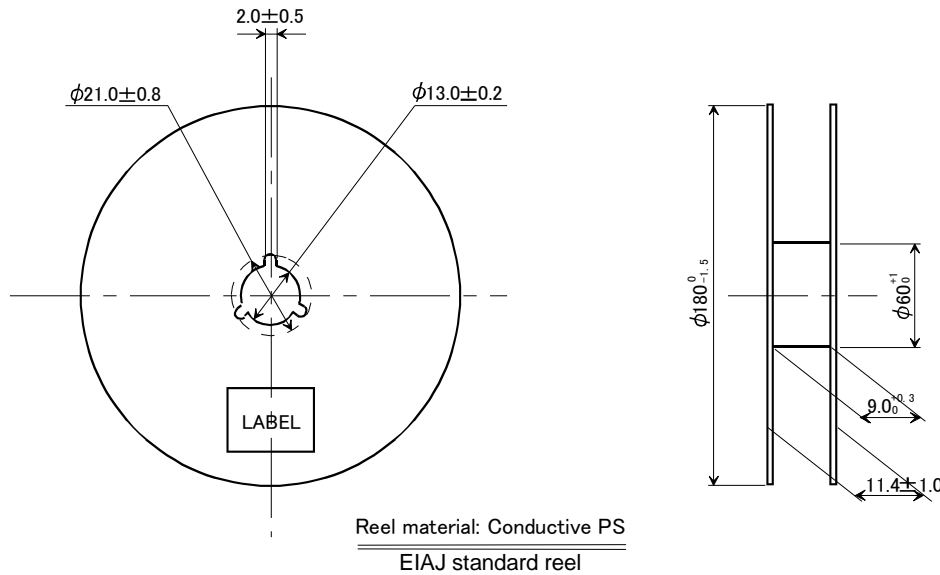
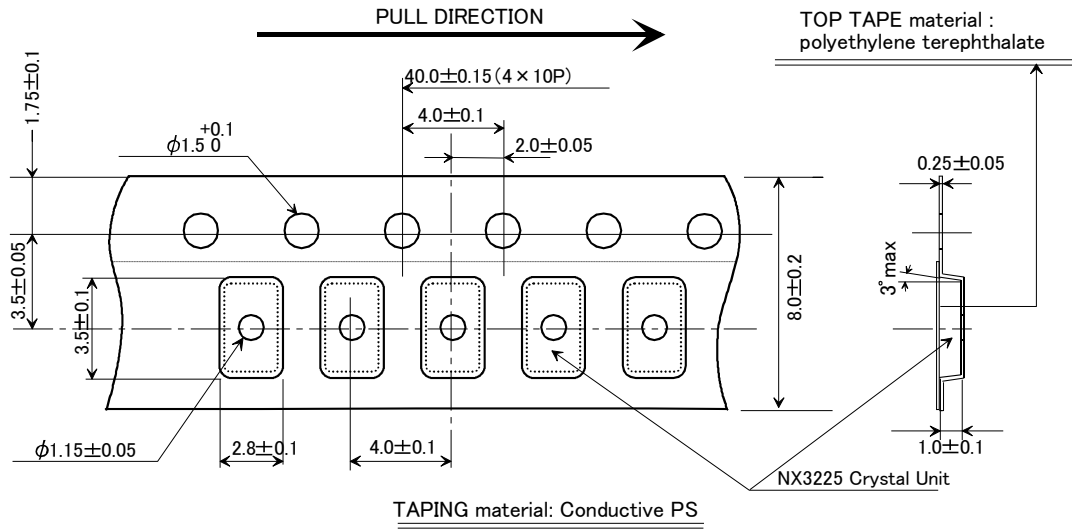

	Date of Revise	Charge	Approved	Reason
B	26 Mar. 2013	T. Shimizu	K. Oguri	The appearance of a drawing was corrected.
	Date	Name	Third Angle Projection	Tolerance
Drawn	30.Jun.2006	H.Yagishita	Dimension:mm	---
Designed	30.Jun.2006	H.Yagishita	Title	Drawing No.
Checked	30.Jun.2006	K.Kubota		
Approved	30.Jun.2006	T.Ishii		
			NX3225 Series Taping and Reel Spec.	EXK17B-00247
				Scale
				Rev.
				B

NIHON DEMPA KOGYO CO., LTD.

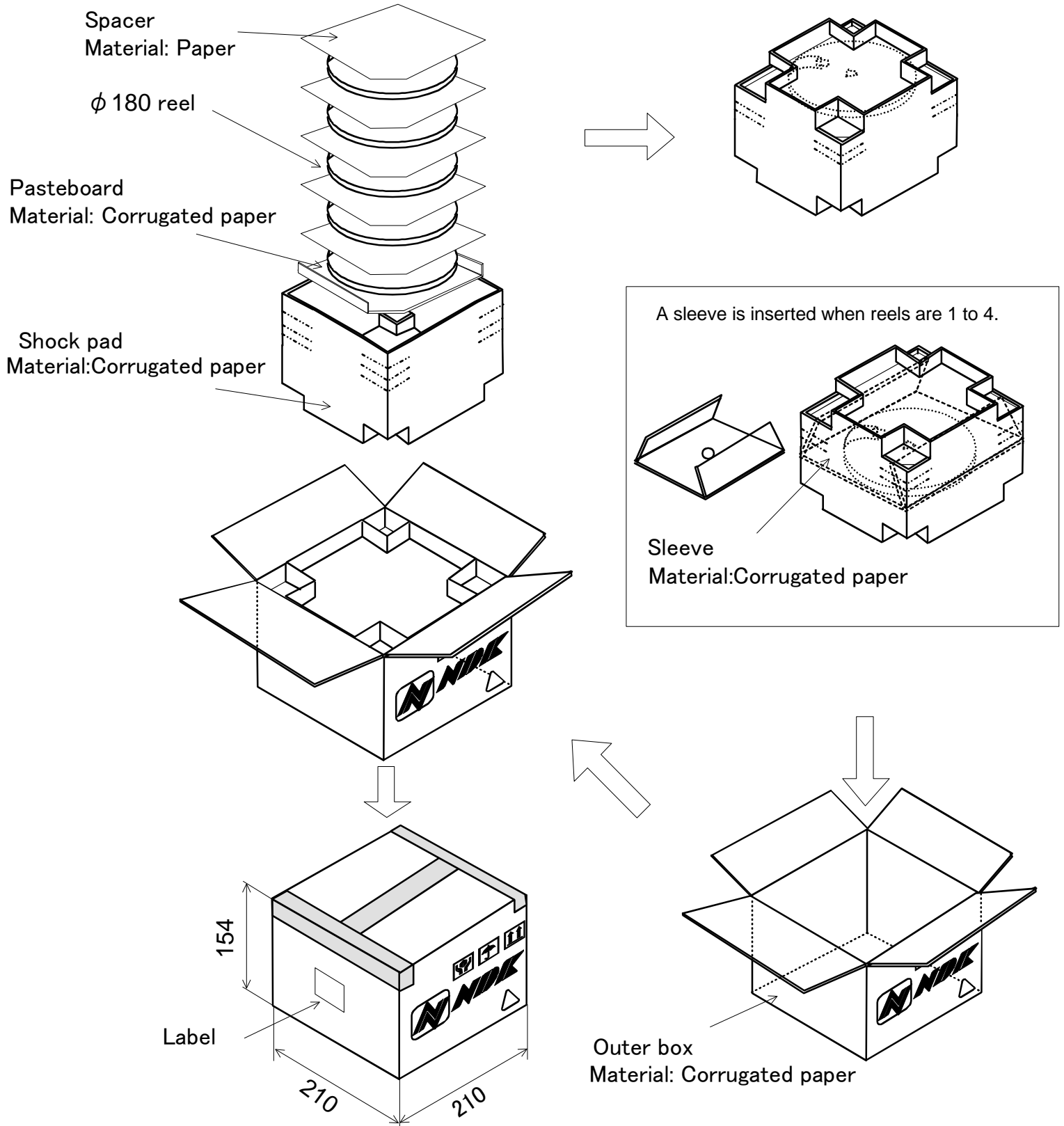

	Date of Revise	Charge	Approved	Reason
C	4 Jul. 2012	H.Okubo	K.Oguri	Addition of condition when reels are 1 to 4.
	Date	Name	Third Angle Projection	Tolerance
Drawn	26 Feb. 2010	H. Ohkubo	Dimension:mm	-----
Designed	26 Feb. 2010	K.Oguri	Title	Drawing No.
Checked	26 Feb. 2010	K.Oguri		
Approved	26 Feb. 2010	J. Nakamura	180 dia. Reel package	EEK17B-00015
				C

NIHON DEMPA KOGYO CO., LTD.

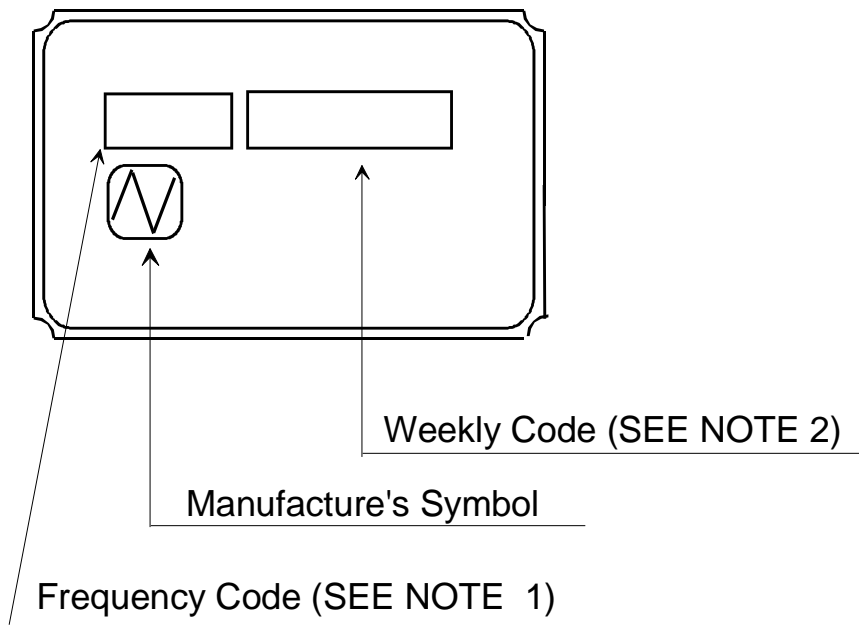

1. Frequency Code

Marking Frequency is consist of two digits, first two digits of Nominal Frequency

Example

Nominal Frequency	28.636363 MHz
Frequency Code	28

2. Weekly Code

Last one digit of Year and Weekly Code (01 to 53)

Example

11.Mar.2011 Production : 110

*Marking digits are not include a decimal point and dot mark.

	Date of Revise	Charge	Approved	Reason	
	Date	Name	Third Angle Projection	Tolerance	Scale
Drawn	10.Mar.2011	Y.Ikeda	Dimension:mm		/
Designed	10.Mar.2011	Y.Ikeda	Title Crystal Holder Marking	Drawing No. EXH11B-00457	Rev.
Checked	10.Mar.2011	M.Sato			
Approved	10.Mar.2011	K.Ueki			

NIHON DEMPA KOGYO CO., LTD.

Reliability assurance item

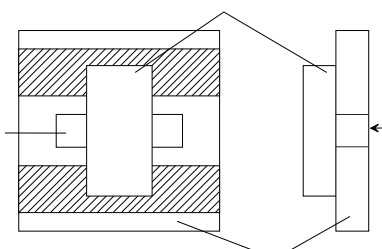
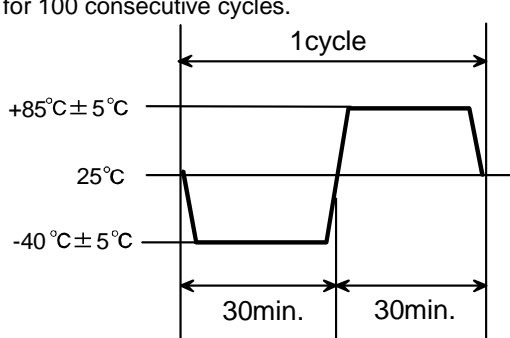
No.	Test Item	Test Methods	Specification Code
1	Drop	Devices are dropped from the height 75cm onto wooden block. (more than 30mm thickness.) Execution 3 times random drops.	A
2	Shock	Devices are shocked to half sine wave (981m/s^2) three mutually perpendicular axis each 3 times.	A
3	Vibration	Frequency Range : 10 to 55 Hz Amplitude : 1.5mm Sweep time : 1 min. Test time : 2.0 hours	A
4	Electrode adherent strength	Reflow soldering shall be used for soldering on test fixture (Glass fiber epoxy laminate : Thickness $1.6\text{mm} \pm 0.2\text{mm}$) shown below. ($220 \sim 240^\circ\text{C}$) Be careful to happen the heat shock. 	B
5	Solderability	Pre-heat temperature : 150°C Pre-heat Time : 60~120sec. Peek temperature : $240 \pm 5^\circ\text{C}$ Soldering temperature : Over 215°C Test time : 10~30 sec.	C
6	Resistance to soldering heat	Pre-heat temperature : 150°C Pre-heat time : 60 ~ 120sec. Test temperature : $260 \pm 5^\circ\text{C}$ Test time : 10 sec. Max.	A, B
7	Resistance to cold	Leave at $-40^\circ\text{C} \pm 2^\circ\text{C}$ for 500 hours.	A
8	Resistance to heat	Leave at $+85^\circ\text{C} \pm 2^\circ\text{C}$ for 500 hours.	A
9	Humidity	Devices are left in temperature at $+60^\circ\text{C}$ with relative humidity of 90~95% for 500 hours.	A
10	Thermal shock	Devices are left into the following temperature cycle as shown in (Figure 1) for 100 consecutive cycles. 	A, B

Specification code	Specification
A	Frequency tolerance and series resistance should be cleared.
B	After testing unless cracking of materials view of eyes.
C	The leads shall acquire a new solder coat cover at 90% of immersed area.

Recommendation reflow condition

1. IR reflow condition

