

RoHS Compliant
Directive 2002/95/EC

SPECIFICATION

Customer: _____

Item:	Crystal Unit
Type:	NX3225GA
Nominal Frequency:	26.000MHz
Customer's Spec. No.:	---
NDK Spec. No.:	EXS00A-CG01972

Receipt

Charge:

Sales		Tel. (33)-1-60-95-0000	Approved	K.Ueki
Engineer	1 st Eng. Dept. Shariman	Tel. (81)-4-2900-6631	Checked	---
			Drawn	R.Shariman

Revision Record

Rev.	Rev. Date	Items	Contents	Remarks
---	22. Dec. 2009	Issue	---	---
A	7. Apr. 2011	6.3 Relative series resistance of unwanted mode	Additional	---

- 1.Customer specifications number : ---
- 2.NDK specification number : EXS00A-CG01972
- 3.Type : NX3225GA
- 4.Electrical characteristics
- 4.1 Nominal frequency : 26.000MHz
- 4.2 Overtone order : Fundamental
- 4.3 Adjustment tolerance : $\pm 20 \times 10^{-6}$ max. (+25 °C)
- 4.4 Tolerance over the temperature range : $\pm 40 \times 10^{-6}$ max. (-40 ~ +85 °C)
The reference temperature shall be 25°C
- 4.5 Equivalent resistance (R_1) : 50Ω max.
- 4.6 Shunt capacitance (C_0) : 1.2±0.3pF.
- 4.7 Motional capacitance (C_1) : 4.8fF ± 30%
- 4.8 Motional inductance (L_1) : 7.8mH ± 30%
- 4.9 Pulling sensitivity : 19.1×10^{-6} /pF ± 30% (Where $C_L=10$ pF)
- 4.10 Maximum drive level : 200uW max.
- 4.11 Insulation resistance : Terminal to terminal insulation resistance also terminal to cover insulation resistance must be 500MΩ (min) when DC100V ±15V is applied.
5. Measurement circuit
- 5.1 Frequency measurement
- Measuring instrument : IECπ circuit
- Load capacitance(C_L) : 10pF
- Excitation level : 10μW
- 5.2 Equivalent resistance measurement
- Measuring instrument : IECπ circuit
- Load capacitance(C_L) : Series
- Level of drive : 10μW
6. Other performances
- 6.1 Storage temperature range : -40~+85°C
- 6.2 Air-tightness : Less than 3×10^{-9} Pa m³/s (Helium leak detector)
- 6.3 Relative series resistance : 10 min.
of unwanted mode
- 6.4 Recommended oscillation margin
For stable oscillation, oscillation margin of min. 600Ω is recommended.
When the circuit does not have enough value as above, please contact us.
7. Examination results document
Since a performance is guaranteed, an examination results document does not submit.
8. Application drawing
- 8.1 External dimension : EXD14B-00388
- 8.2 Taping and reel figure : EXK17B-00247
- 8.3 Reel Packing : EXK17B-00130
- 8.4 Holder marking : EXH11B-00027
- 8.5 Reliability assurance Item : EXS30B-00020
- 8.6 Recommendation reflow profile : EXS30B-00344

9. Notice

- 9.1. Order items are manufactured according to specification. As to conditions, which are not indicated in this specification and unpredictable such as applied condition and oscillation margin, please check them beforehand.
- 9.2. Unless we receive request for modification within 3 weeks from the issue date of this NDK specification sheet, we will supply products according to this specification. Also, if you'd like to modify specification of order, which has been placed with delivery request within 3 weeks from the issue data of this specification sheet, we would like to discuss with you separately.
- 9.3. In no event shall the company be liable for any product failure resulting from an inappropriate handling or operation of the product beyond the scope of its guarantee.
- 9.4. Where any change to the process condition is made due to the change(s) in the production line, inform personnel of the specifications.
- 9.5. Should this specification data give rise to any disputes relating to any intellectual property rights or any other rights of a third person, the company shall not indemnify anyone for any damage. Their disclosure must not be construed as the grant of a license to use any of the intellectual property rights owned by the company.
- 9.6. If you intend to use products listed on this specification for applications that may result in loss of life or assets (controls relating to safety, medical equipment, aeronautical equipment, space equipment, etc.), please do not fail to advise us of your intention beforehand.
- 9.7. In the company's production process whatever amount of ozone depleting substances (ODS) as specified in the Montreal protocol is not used.
- 9.8. Information contained in this specification must not be quoted, reproduced or used for other purposes including processing either in part or in full without obtaining prior approval from the company.

10. Prohibited items

Be sure to use the product under the following conditions. Otherwise, the characteristics deterioration or destruction of the product may result.

(1) Reflow soldering heat resistance

Peak temperature: 265°C, 10 sec

Heating: 230°C or higher, 40 sec

Preheating: 150°C to 180°C, 120 sec

Reflow passage times: twice

(2) Manual soldering heat resistance

Pressing a soldering iron of 400°C on the terminal electrode for four seconds (twice).

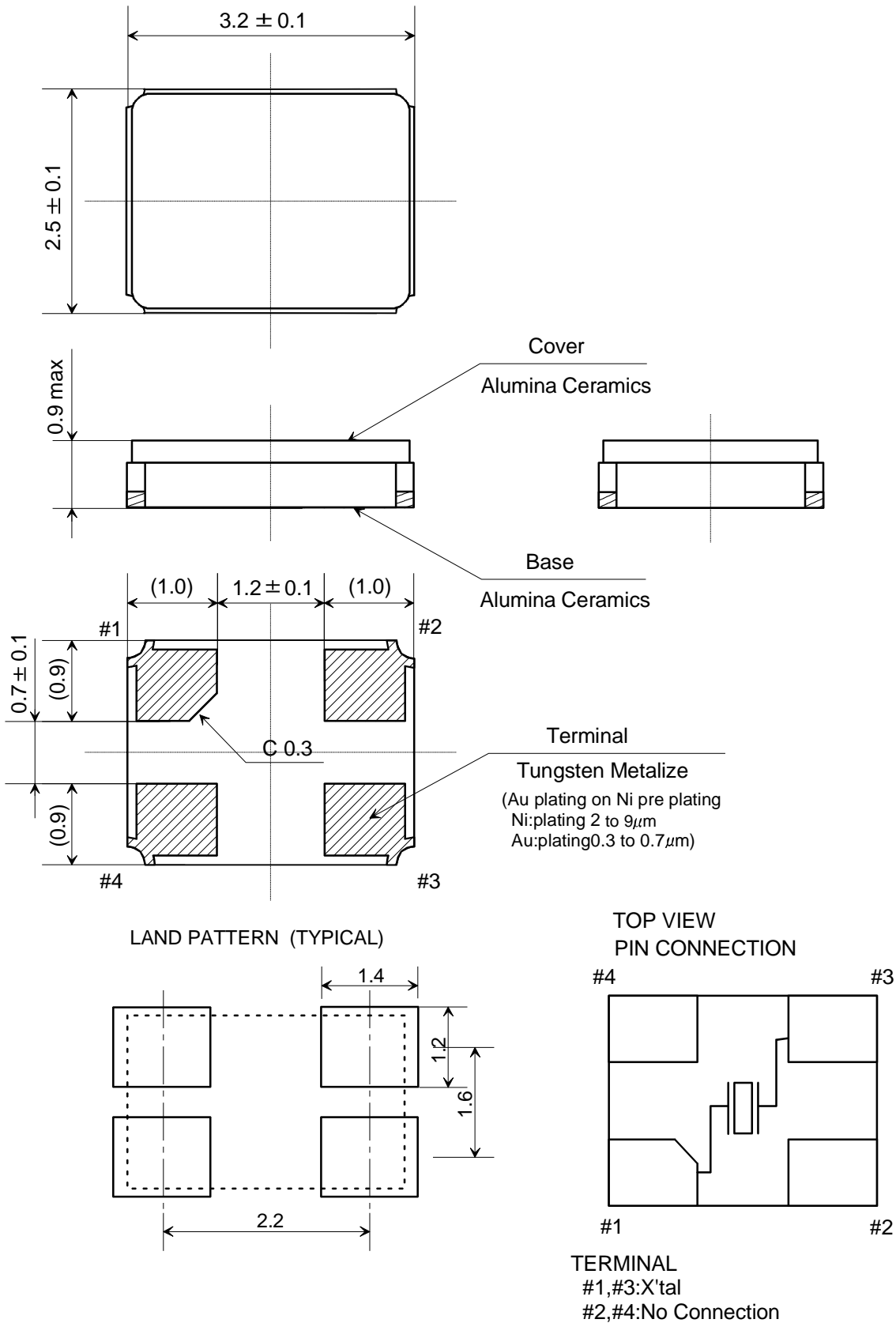

	Date of Revise	Charge	Approved	Reason	
A					
	Date	Name	Third Angle Projection	Tolerance	Scale
Drawn	30.Jun.2006	H.Yagishita	Dimension:mm	---	- / -
Designed	30.Jun.2006	H.Yagishita	Title NX3225GA Dimension Drawing	Drawing No. EXD14B-00388	Rev.
Checked	30.Jun.2006	K.Kubota			
Approved	30.Jun.2006	T.Ishii			

NIHON DEMPA KOGYO CO., LTD.

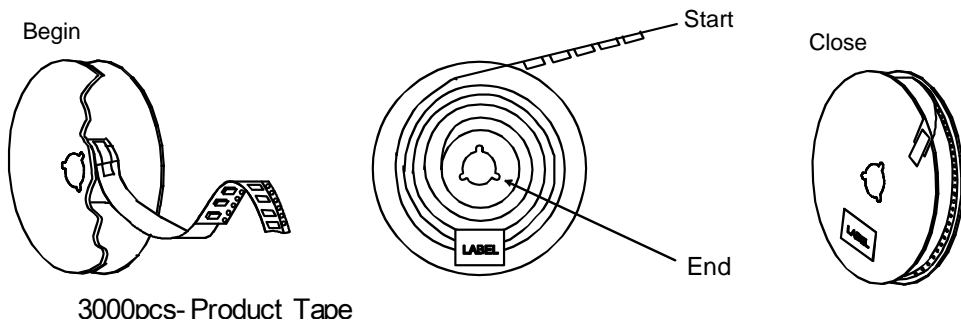
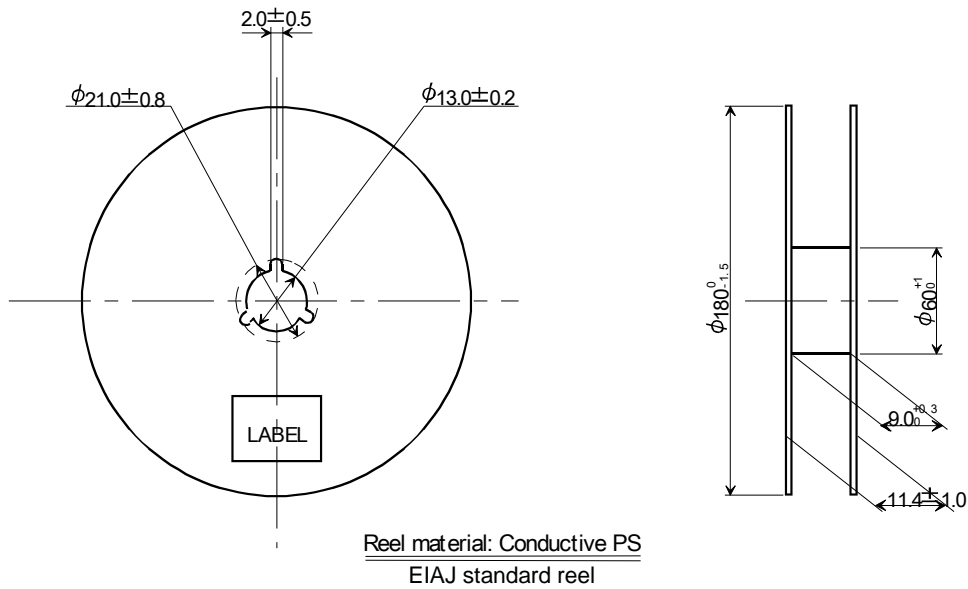
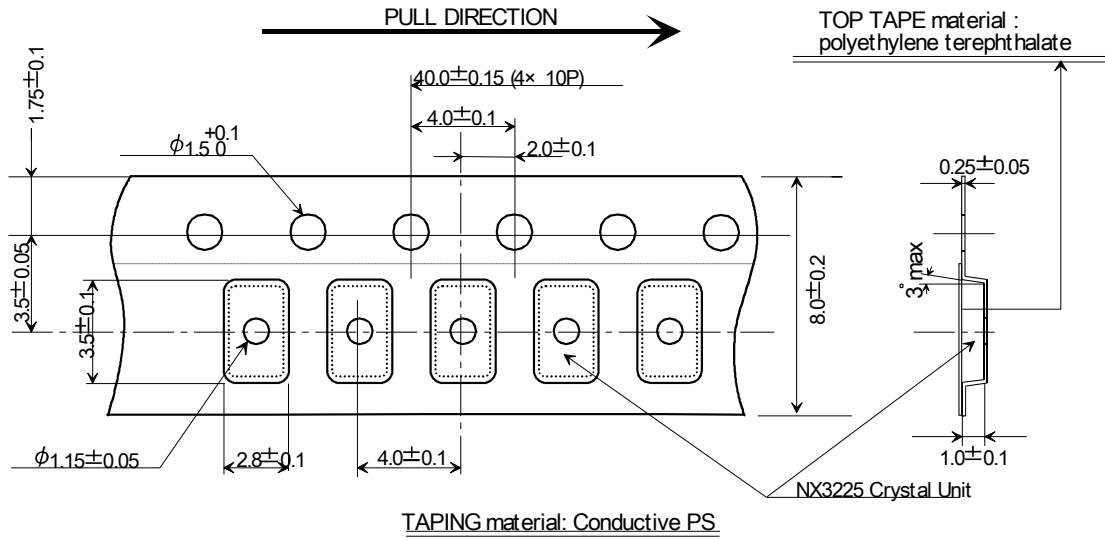

Date of Revise	Charge	Approved	Reason		
A					
Drawn	Date	Name	Third Angle Projection	Tolerance	Scale
	30.Jun.2006	H.Yagishita	Dimension:mm	---	- / -
Designed	Date	Name	Title	Drawing No.	Rev.
	30.Jun.2006	H.Yagishita	NX3225 Series Taping and Reel Spec.	EXK17B-00247	
Checked	30.Jun.2006	K.Kubota			
Approved	30.Jun.2006	T.Ishii			

NIHON DEMPA KOGYO CO., LTD.

For 8 and 12mm width carrier tape

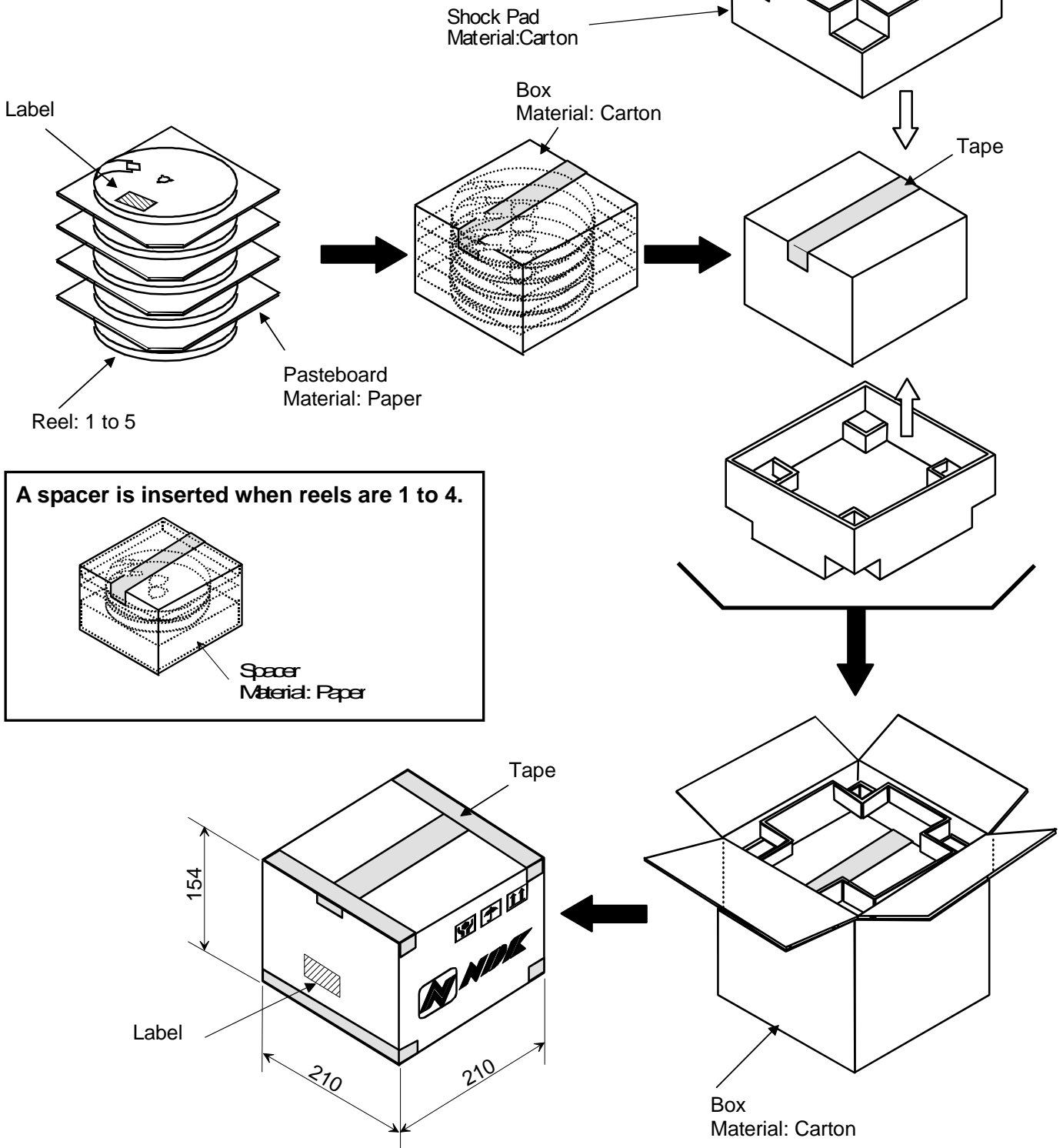

A spacer is inserted when reels are 1 to 4.

	Date of Revise	Charge	Approved	Reason
B	30 Jun. 2008	K. Oguri	K. Miyashita	The pasting method of shipping tape was corrected.
	Date	Name	Third Angle Projection	Tolerance
Drawn	9.Aug.2002	K.Oguri	Dimension:mm	Scale
Designed	9.Aug.2002	K.Oguri	Title	Drawing No.
Checked	-----	-----	180mm reel Packing	EXK17B-00130
Approved	9.Aug.2002	K.Miyashita		
				B

NIHON DEMPA KOGYO CO., LTD.

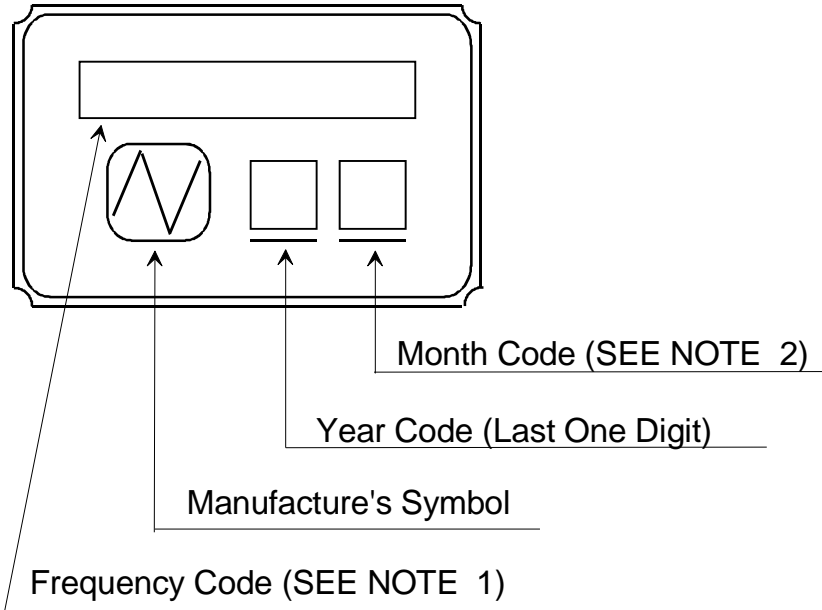

NOTE

1. Frequency Code

Marking Frequency is consist of five digits, first five digits of Nominal Frequency

Example

Nominal Frequency	28.636363 MHz
Frequency Code	28.636

2. Month Code Table

Month	1 Jan.	2 Feb.	3 Mar.	4 Apr.	5 May.	6 Jun.	7 Jul.	8 Aug.	9 Sep.	10 Oct.	11 Nov.	12 Dec.
Month Code	1	2	3	4	5	6	7	8	9	X	Y	Z

*Marking digits are not include a decimal point and dot mark.

	Date of Revise	Charge	Approved	Reason		
B	9.Nov.2000	H.Yagishita	T.Ishii	Change Form		
	Date	Name	Third Angle Projection	Tolerance	Scale	
Drawn	3.Aug.1999	Y.Morizumi	Dimension:mm		/	
Designed	3.Aug.1999	Y.Morizumi	Title		Drawing No.	Rev.
Checked	-----	-----	Crystal Holder Marking		EXH11B-00027	B
Approved	3.Aug.1999	T.Ishii				

NIHON DEMPA KOGYO CO., LTD.

Reliability assurance item

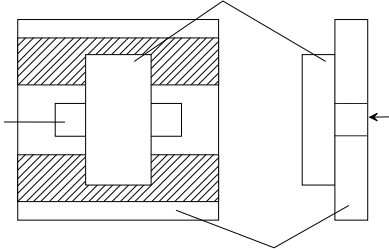
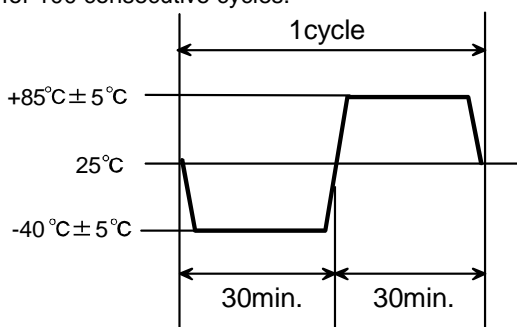
No.	Test Item	Test Methods	Specification Code
1	Drop	Devices are dropped from the height 75cm onto wooden block. (more than 30mm thickness.) Execution 3 times random drops.	A
2	Shock	Devices are shocked to half sine wave (981m/s^2) three mutually perpendicular axis each 3 times.	A
3	Vibration	Frequency Range : 10 to 55 Hz Amplitude : 1.5mm Sweep time : 1 min. Test time : 2.0 hours	A
4	Electrode adherent strength	Reflow soldering shall be used for soldering on test fixture (Glass fiber epoxy laminate : Thickness $1.6\text{mm} \pm 0.2\text{mm}$) shown below. ($220 \sim 240^\circ\text{C}$) Be careful to happen the heat shock. 	B
5	Solderability	Pre-heat temperature : 150°C Pre-heat Time : 60~120sec. Peek temperature : $240 \pm 5^\circ\text{C}$ Solderind temperature : Over 215°C Test time : 10~30 sec.	C
6	Resistance to soldering heat	Pre-heat temperature : 150°C Pre-heat time : 60 ~ 120sec. Test temperature : $260 \pm 5^\circ\text{C}$ Test time : 10 sec. Max.	A, B
7	Resistance to cold	Leave at $-40^\circ\text{C} \pm 2^\circ\text{C}$ for 500 hours.	A
8	Resistance to heat	Leave at $+85^\circ\text{C} \pm 2^\circ\text{C}$ for 500 hours.	A
9	Humidity	Devices are left in temperature at $+60^\circ\text{C}$ with relative humidity of 90~95% for 500 hours.	A, D
10	Thermal shock	Devices are left into the following temperature cycle as shown in (Figure 1) for 100 consecutive cycles. 	A, B

Specification code	Specification
A	Frequency tolerance and series resistance should be cleared.
B	After testing unless cracking of materials view of eyes and unless break of seal.
C	The leads shall acquire a new solder coat cover at 90% of immersed area.
D	Insulation resistance shall be greater than $500\text{M}\Omega$

