

- 1.Customer specifications number :
 2.NDK specification number : EXS00A-CG02611
 3.Type : NX3225GA
 4.Electrical characteristics
 4.1 Nominal frequency : 32.000MHz
 4.2 Overtone order : Fundamental
 4.3 Frequency tolerance : $\pm 20 \times 10^{-6}$ max. (+25 °C)
 4.4 Frequency versus temperature characteristics : $\pm 20 \times 10^{-6}$ max. (0 ~ +70 °C)
 The reference temperature shall be 25°C
 4.5 Equivalent resistance : 50Ωmax.
 4.6 Maximum drive Level : 200μW max.
 4.7 Insulation resistance : Terminal to terminal insulation resistance also terminal to cover insulation resistance must be 500MΩ (min) when DC100V ±15V is applied.
 4.8 Typical value of equivalent circuit (For reference only)
 * Shunt capacitance (C₀) : 1.00pF typ.
 * Motional capacitance (C₁) : 4.32fF typ.
 * Motional inductance (L₁) : 5.73mH typ.
 * Motional resistance (R₁) : 17.2Ω typ.
5. Measurement circuit
 5.1 Frequency measurement
 Measuring instrument : IECπ circuit
 Load capacitance (CL) : 10pF
 Excitation level : 10μW
 5.2 Equivalent resistance measurement
 Measuring instrument : IECπ circuit
 Load capacitance (CL) : Series
 Level of drive :10μW
6. Other performances
 6.1 Storage temperature range : -40~+85°C
 6.2 Air-tightness : Less than 3×10^{-9} Pa m³/s (Helium leak detector)
7. Examination results document
 Since a performance is guaranteed, an examination results document does not submit.
8. Application drawing
 8.1 External dimension : EXD14B-00388
 8.2 Taping and reel figure : EXK17B-00247
 8.3 Holder marking : EXH11B-00027
 8.4 Reliability assurance Item : EXS30B-00020
 8.5 Recommendation reflow profile : EXS30B-00344

9. Notice

Order items are manufactured according to specification. As to conditions, which are not indicated in this specification and unpredictable such as applied condition and oscillation margin, please check them beforehand.

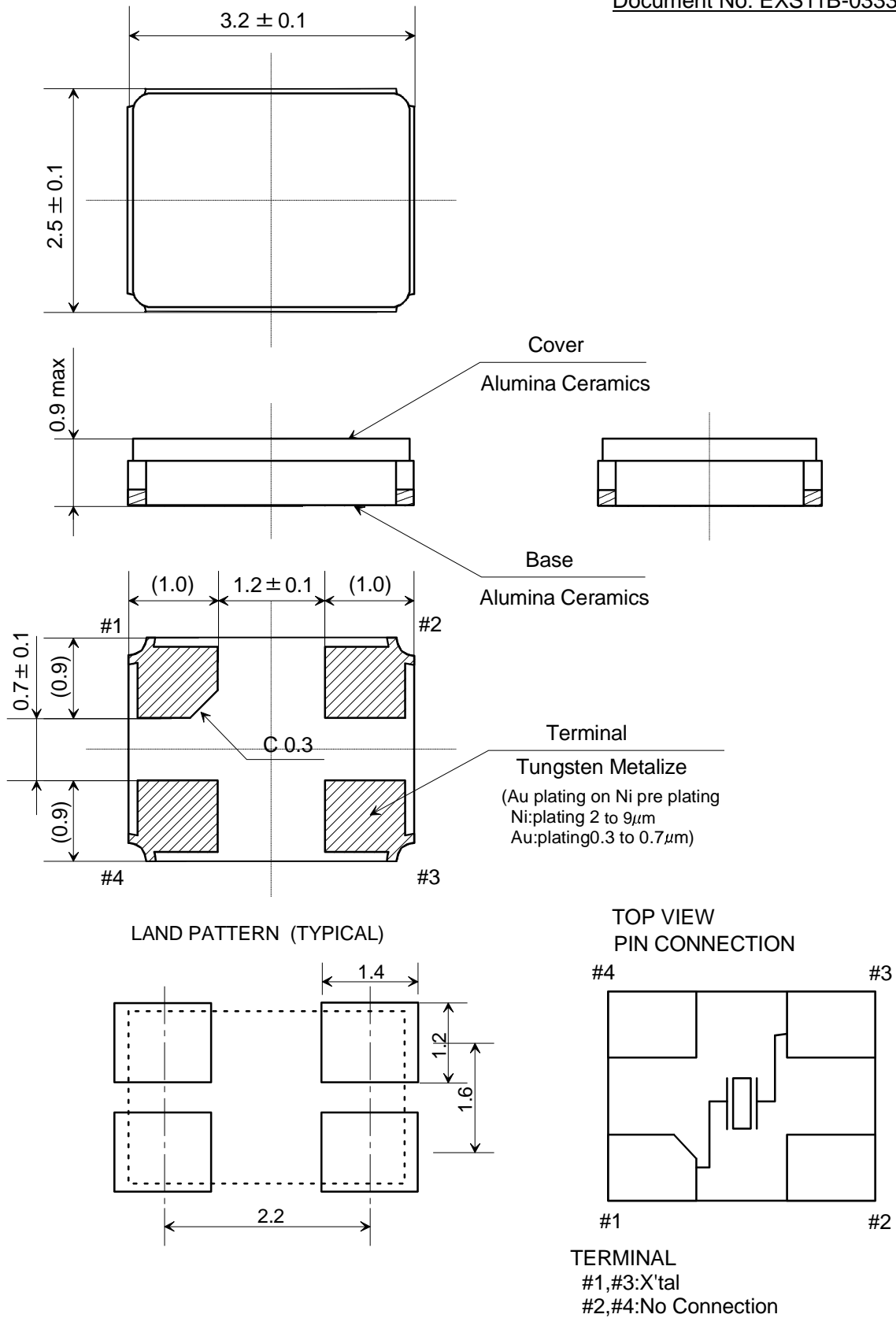

Date of Revise	Charge	Approved	Reason
A			
Date	Name	Third Angle Projection	Tolerance
30.Jun.2006	H.Yagishita	Dimension:mm	---
Date	Name	Title	Scale
30.Jun.2006	H.Yagishita	NX3225GA Dimension Drawing	- / -
Date	Name		Drawing No.
30.Jun.2006	K.Kubota		EXD14B-00388
Date	Name	Rev.	
30.Jun.2006	T.Ishii		

NIHON DEMPA KOGYO CO., LTD.

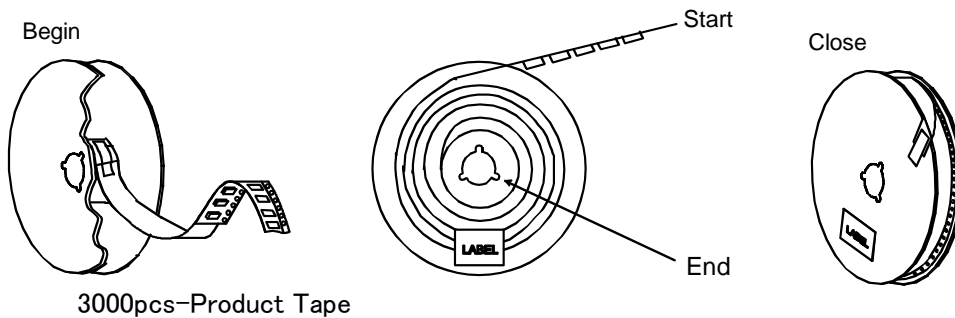
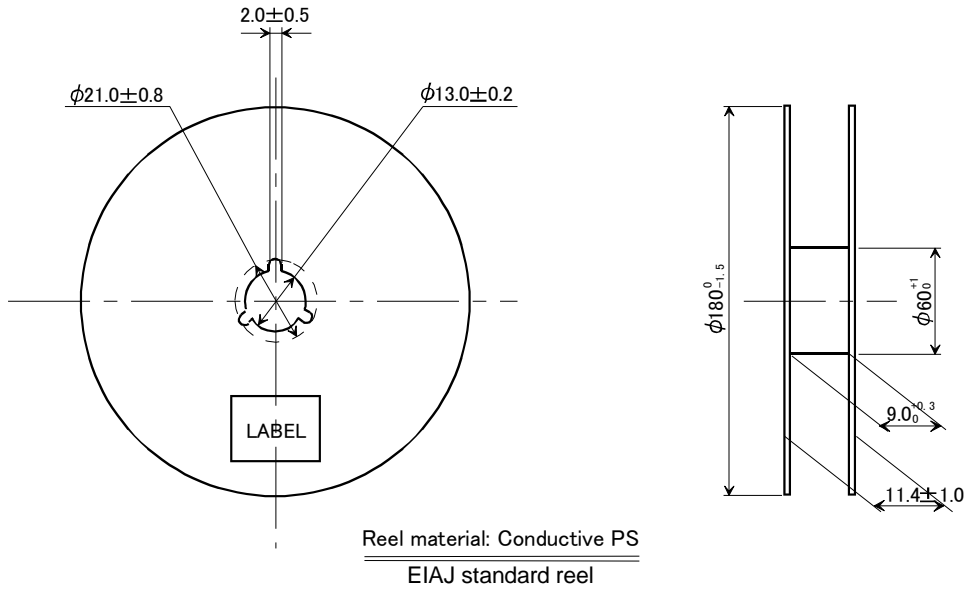
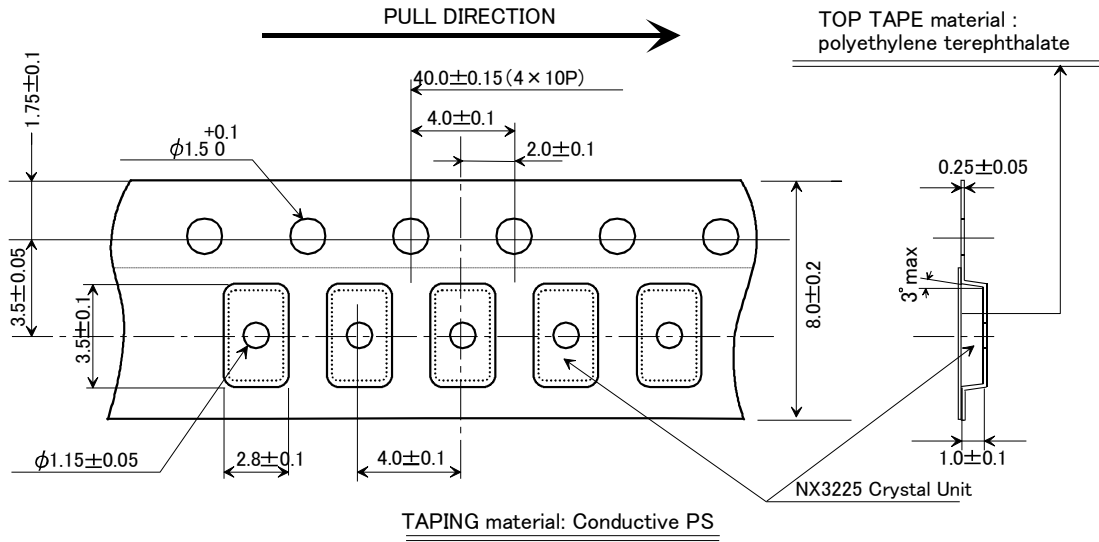

Date of Revise	Charge	Approved	Reason		
A					
Drawn	Date	Name	Third Angle Projection	Tolerance	Scale
	30.Jun.2006	H.Yagishita	Dimension:mm	---	- / -
Designed	Date	Name	Title	Drawing No.	Rev.
	30.Jun.2006	H.Yagishita	NX3225 Series Taping and Reel Spec.	EXK17B-00247	
Checked	30.Jun.2006	K.Kubota			
Approved	30.Jun.2006	T.Ishii			

NIHON DEMPA KOGYO CO., LTD.

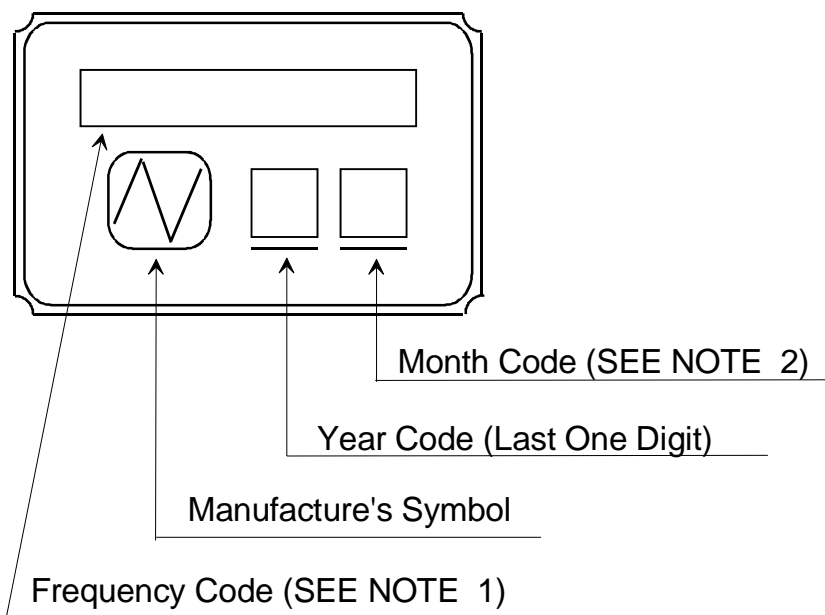

NOTE

1. Frequency Code

Marking Frequency is consist of five digits, first five digits of Nominal Frequency

Example

Nominal Frequency	28.636363 MHz
Frequency Code	28.636

2. Month Code Table

Month	1 Jan.	2 Feb.	3 Mar.	4 Apr.	5 May.	6 Jun.	7 Jul.	8 Aug.	9 Sep.	10 Oct.	11 Nov.	12 Dec.
Month Code	1	2	3	4	5	6	7	8	9	X	Y	Z

*Marking digits are not include a decimal point and dot mark.

	Date of Revise	Charge	Approved	Reason	
B	9.Nov.2000	H.Yagishita	T.Ishii	Change Form	
	Date	Name	Third Angle Projection	Tolerance	
Drawn	3.Aug.1999	Y.Morizumi	Dimension:mm	Scale	
Designed	3.Aug.1999	Y.Morizumi	Title Crystal Holder Marking	Drawing No. EXH11B-00027	
Checked	-----	-----			Rev.
Approved	3.Aug.1999	T.Ishii			B

NIHON DEMPA KOGYO CO., LTD.

Reliability assurance item

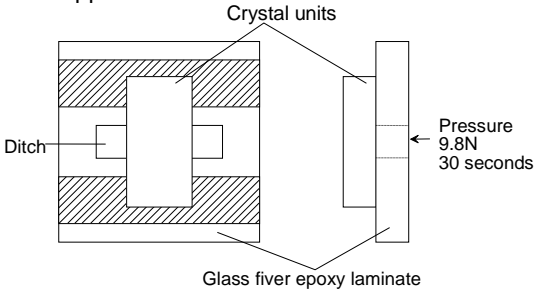
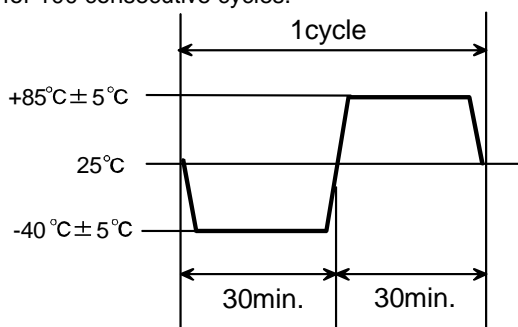
No.	Test Item	Test Methods	Specification Code
1	Drop	Devices are dropped from the height 75cm onto wooden block. (more than 30mm thickness.) Execution 3 times random drops.	A
2	Shock	Devices are shocked to half sine wave (981m/s ²) three mutually perpendicular axis each 3 times.	A
3	Vibration	Frequency Range : 10 to 55 Hz Amplitude : 1.5mm Sweep time : 1 min. Test time : 2.0 hours	A
4	Electrode adherent strength	Reflow soldering shall be used for soldering on test fixture (Glass fiber epoxy laminate : Thickness 1.6mm+/-0.2mm) shown below. (220~240°C) Be careful to happen the heat shock. 	B
5	Solderability	Pre-heat temperature : 150°C Pre-heat Time : 60~120sec. Peek temperature : 240±5°C Soldering temperature : Over 215°C Test time : 10~30 sec.	C
6	Resistance to soldering heat	Pre-heat temperature : 150 °C Pre-heat time : 60 ~ 120sec. Test temperature : 260 ± 5 °C Test time : 10 sec. Max.	A, B
7	Resistance to cold	Leave at -40°C ± 2 °C for 500 hours.	A
8	Resistance to heat	Leave at +85°C ± 2 °C for 500 hours.	A
9	Humidity	Devices are left in temperature at +60°C with relative humidity of 90~95% for 500 hours.	A, D
10	Thermal shock	Devices are left into the following temperature cycle as shown in (Figure 1) for 100 consecutive cycles. 	A, B

Specification code	Specification
A	Frequency tolerance and series resistance should be cleared.
B	After testing unless cracking of materials view of eyes and unless break of seal.
C	The leads shall acquire a new solder coat cover at 90% of immersed area.
D	Insulation resistance shall be greater than 500MΩ

Recommendation reflow condition

1.IR reflow condition

