

SPECIFICATION

Customer: ELTECH

Item:	Crystal Unit
Type:	NX3225GA
Nominal Frequency:	12.000 MHz
Customer's Spec. No.:	
NDK Spec. No.:	EXS00A-CG07452

Receipt

Revision Record						
Rev.	Date	Items	Contents	Approved	Checked	Drawn
---	27. Nov. 2018	Issue	---	H.Kobayashi	---	M.Sato

1. Customer's Spec. No. : ---
2. NDK Spec. No. : EXS00A-CG07452
3. Type : NX3225GA

4. Electrical Specifications

	Parameters	SYM.	Electrical Spec.				Notes
			min	typ	max	Units	
1	Nominal frequency	f_{nom}	12.000			MHz	
2	Overtone order	-	Fundamental			-	
3	Frequency tolerance	-	-30	-	+30	$\times 10^{-6}$	at +25°C
4	Frequency versus temperature characteristics	-	-30	-	+30	$\times 10^{-6}$	at -40~+85°C The reference temperature shall be +25°C
5	Equivalent resistance	-	-	-	100	Ω	IEC PI-network/Series
6	Load capacitance	C_L	-	12	-	pF	IEC PI-network
7	Level of drive	-	-	10	200	μW	
8	Operating temperature range	T_{opr}	-40	-	+85	°C	
9	Storage temperature range	T_{str}	-40	-	+85	°C	
10	Insulation resistance	-	500	-	-	M Ω	When terminal to terminal and terminal to cover were applied at DC100V $\pm 15V$.
11	Air-tightness	-	-	-	3.0×10^{-9}	Pa m ³ /s	Helium leak detector

5. Examination results document

Since a performance is guaranteed, an examination results document does not submit.

6. Application drawing

- 6.1 External dimension : EXD14B-00388
- 6.2 Taping and reel figure : EXK17B-00247
- 6.3 Holder marking : EXH11B-00027
- 6.4 Reliability assurance Item : EXS30B-00020
- 6.5 Recommendation reflow profile : EXS30B-00344

7. Notes on use

7-1 Even if the appearance color etc. of the product differs by purchasing the component parts by more than two companies, there is no influence on the characteristics and reliability.

7-2 IN THE CASE OF THE FOLLOWING ITEMS, WE ARE NOT RESPONSIBLE FOR WARRANTY / COMPENSATION.

(1) WHEN PRODUCTS OF THIS SPECIFICATION ARE USED FOR EQUIPMENT RELATED TO HUMAN LIFE OR PROPERTY, IT IS THE RESPONSIBILITY OF THE CUSTOMER TO CONFIRM THE INFLUENCE ON THIS PRODUCT AND EQUIPMENT TO BE USED BEFOREHAND, CONDUCT NECESSARY SAFETY DESIGN (INCLUDING REDUNDANT DESIGN, MALFUNCTION PREVENTION DESIGN, etc.), AND PLEASE USE IT AFTER SECURING SUFFICIENT SAFETY OF EQUIPMENT.

1. SAFETY-RELATED EQUIPMENT SUCH AS AUTOMOBILES, TRAINS, SHIPS, etc., OR EQUIPMENT DIRECTLY INVOLVED IN OPERATION
2. AIRCRAFT EQUIPMENT
3. SPACE EQUIPMENT
4. MEDICAL EQUIPMENT
5. MILITARY EQUIPMENT
6. DISASTER PREVENTION / CRIME PREVENTION EQUIPMENT
7. TRAFFIC LIGHT
8. OTHER EQUIPMENT REQUIRING THE SAME PERFORMANCE AS THE ABOVE-MENTIONED EQUIPMENT

(2) IN CASES WHERE IT IS NOT INDICATED IN THE REQUESTED STANDARD AND IS USED UNDER CONDITIONS OF USE (INCLUDING CIRCUIT MARGIN etc.) THAT CAN NOT BE PREDICTED AT THE PRODUCTION STAGE.

(3) WHEN USING ULTRASONIC WELDING MACHINE. (THERE IS A POSSIBILITY THAT THE CHARACTERISTIC DEGRADATION IS CAUSED BY THE RESONANCE PHENOMENON OF THE PIEZOELECTRIC MATERIAL.

(EXAMPLE; CRYSTAL PIECE))

WE WILL NOT TAKE ANY RESPONSIBILITY FOR THE INFLUENCE OF THE CUSTOMERS' PROCESS.

SO, PLEASE SUFFICIENTLY EVALUATE AT A SAMPLE STEP WHEN YOU USE ULTRASONIC WELDING MACHINE.

(4) USING RESIN MOLD MAY AFFECT THE PRODUCT CHARACTERISTIC.

PLEASE MAKE SURE TO TELL OUR SALES CONTACT WHEN YOU USE RESIN MOLD. WE WILL PERFORM INDIVIDUAL CORRESPONDENCE ABOUT A DELIVERY SPECIFICATION AND AN EVALUATION METHOD.

IN ADDITION, IF YOU USE RESIN MOLD WITHOUT CONTACTING US, AND CAUSES DAMAGES AGAINST A CUSTOMER OR A THIRD PARTY, WE WILL NOT BE LIABLE FOR THE DAMAGES AND OTHER RESPONSIBILITIES BECAUSE WE CONSIDER IT IS UNDER SELF-RESPONSIBILITY USING RESIN MOLD.

WE WILL NOT TAKE ANY RESPONSIBILITY FOR THE INFLUENCE OF THE CUSTOMERS' PROCESS. PLEASE SUFFICIENTLY EVALUATE AT A SAMPLE STEP WHEN YOU USE RESIN MOLD.

(5) WHEN PERFORMING IMPROPER HANDLING THAT EXCEEDS THE GUARANTEED RANGE.

7-3 This product cannot be used for equipment related to the safety of automobiles or equipment directly involved in operation.(example: air bag, TPMS, engine control, steering control, brake control etc.)

8. Notes on storage

8-1 When storing the product in high temperature and high humidity condition for a long time, product characteristics (solderability etc.) and packaging condition may be deteriorated. Please store product at temperature + 5°C ~ + 35°C, humidity 85% RH or less. The product is an electronic component, so please do not storage and use, under a dewing state.

8-2 The product storage deadline is 12 months after delivery in unopened state. Please use within storage deadline. If you exceed storage deadline, please check the product characteristics etc, please use.

9. Other Requests

9-1 Please use this specification only for confirmation of the specification of this product.

9-2 If there is a change request, please contact within three weeks from issue date. If there is no communication, we will deliver the product under the contents of this specification. In addition, if the product delivery date is within 3 weeks and there is a change request, we will consult the processing separately.

9-3 NOTES THAT ARE DESCRIBED IN THIS DOCUMENT, IF YOU DID NOT COMPLY WITH THE PROHIBITIONS, AND OTHER PLEASE, INCLUDING THE FAILURE CORRESPONDENCE OR COMPENSATION OR DAMAGES, WE CAN NOT ASSUME THE RESPONSIBILITY, PLEASE UNDERSTAND.

10. Prohibited items

Be sure to use the product under the following conditions. Otherwise, the characteristics deterioration or destruction of the product may result.

(1) Reflow soldering heat resistance

Peak temperature: 265°C, 10 sec

Heating: 230°C or higher, 40 sec

Preheating: 150°C to 180°C, 120 sec

Reflow passage times: twice

(2) Manual soldering heat resistance

Pressing a soldering iron of 400°C on the terminal electrode for four seconds (twice).

When using a soldering iron, press its tip on the part below the sealed part, avoiding the glass-sealed part (otherwise, the glass will melt and air-tightness may be lost)

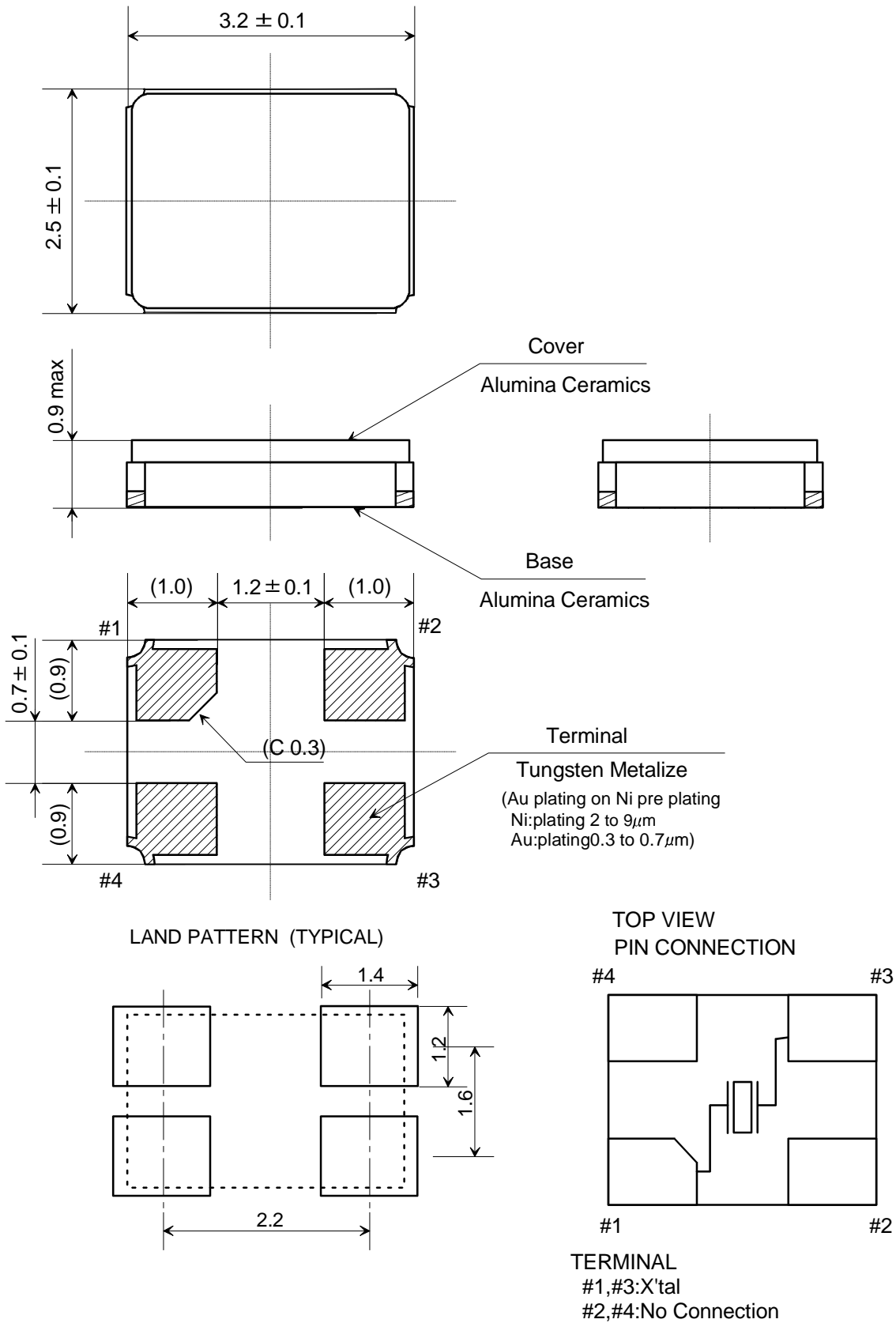

	Date of Revise	Charge	Approved	Reason	
A	19.Jan.2018	M.Harada	H.Kobayashi	Add standard tolerance and change terminal C dimension to reference.	
	Date	Name	Third Angle Projection	Tolerance	Scale
Drawn	30.Jun.2006	H.Yagishita	Dimension:mm	± 0.1	- / -
Designed	30.Jun.2006	H.Yagishita	Title	Drawing No.	Rev.
Checked	30.Jun.2006	K.Kubota			A
Approved	30.Jun.2006	T.Ishii			
			NX3225GA Dimension Drawing	EXD14B-00388	

NIHON DEMPA KOGYO CO., LTD.

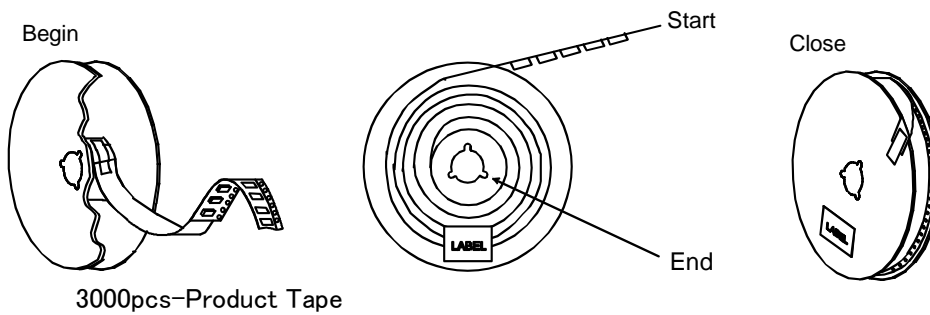
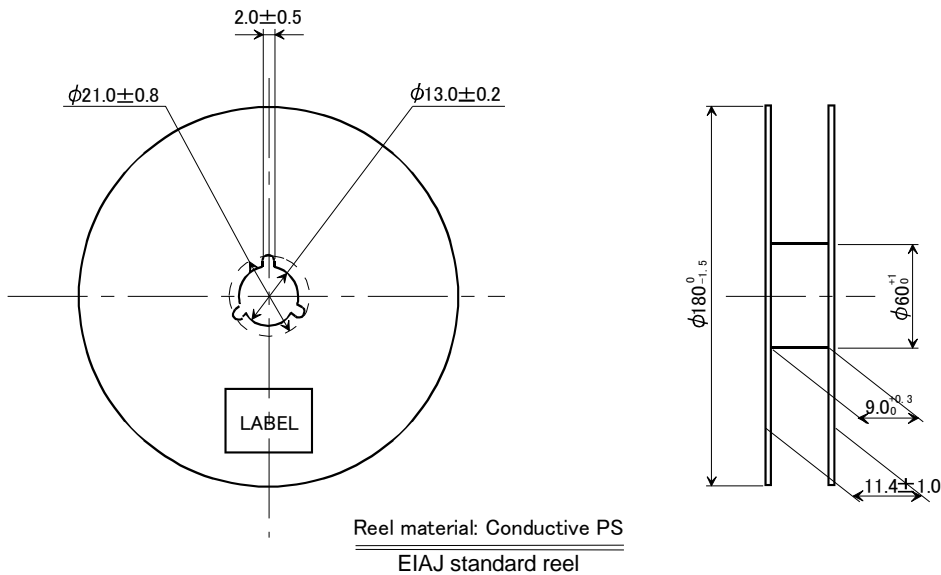
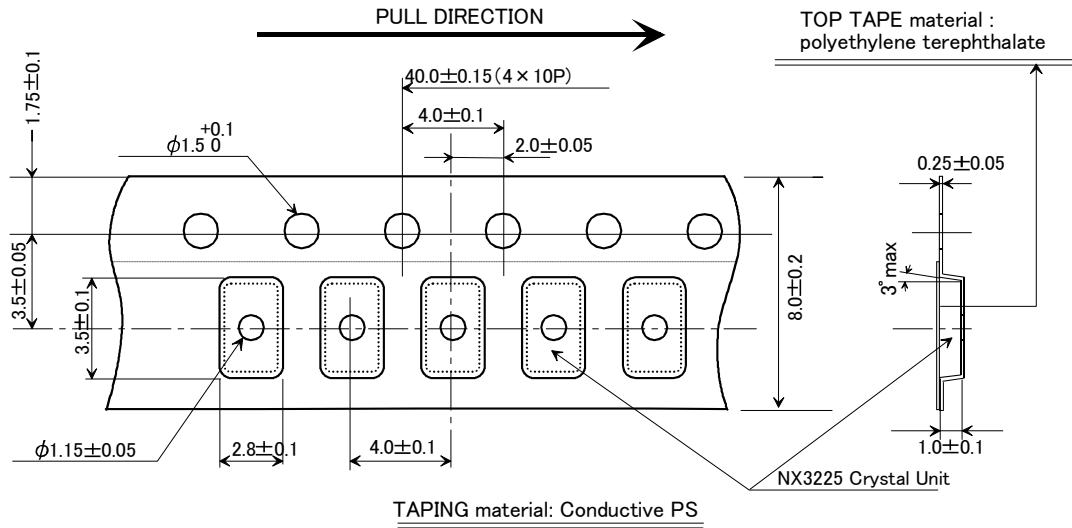

	Date of Revise	Charge	Approved	Reason	
A	26 Mar. 2013	T. Shimizu	K. Oguri	The appearance of a drawing was corrected.	
Drawn	Date	Name	Third Angle Projection	Tolerance	
30.Jun.2006	H.Yagishita	Dimension:mm	---	Scale	
Designed	30.Jun.2006	H.Yagishita	Title	Drawing No.	
Checked	30.Jun.2006	K.Kubota			EXK17B-00247
Approved	30.Jun.2006	T.Ishii			
			NX3225 Series Taping and Reel Spec.	B	

NIHON DEMPA KOGYO CO., LTD.

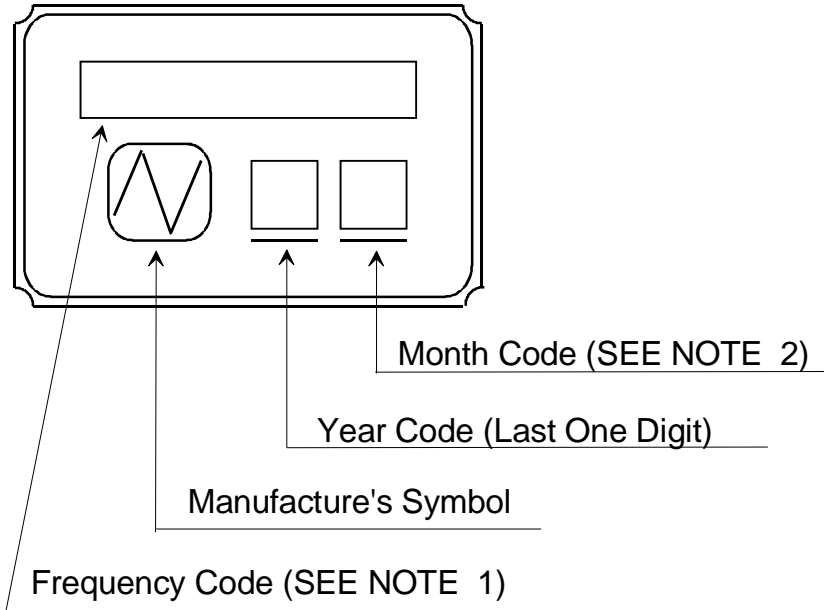

NOTE

1. Frequency Code

Marking Frequency is consist of five digits, first five digits of Nominal Frequency

Example

Nominal Frequency	28.636363 MHz
Frequency Code	28.636

2. Month Code Table

Month	1 Jan.	2 Feb.	3 Mar.	4 Apr.	5 May.	6 Jun.	7 Jul.	8 Aug.	9 Sep.	10 Oct.	11 Nov.	12 Dec.
Month Code	1	2	3	4	5	6	7	8	9	X	Y	Z

*Marking digits are not include a decimal point and dot mark.

	Date of Revise	Charge	Approved	Reason			
B	9.Nov.2000	H.Yagishita	T.Ishii	Change Form			
	Date	Name	Third Angle Projection	Tolerance		Scale	
Drawn	3.Aug.1999	Y.Morizumi	Dimension:mm			/	
Designed	3.Aug.1999	Y.Morizumi	Title Crystal Holder Marking		Drawing No. EXH11B-00027		Rev.
Checked	-----	-----					B
Approved	3.Aug.1999	T.Ishii					

NIHON DEMPA KOGYO CO., LTD.

Reliability assurance item

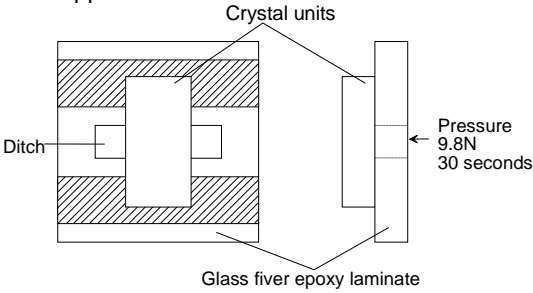
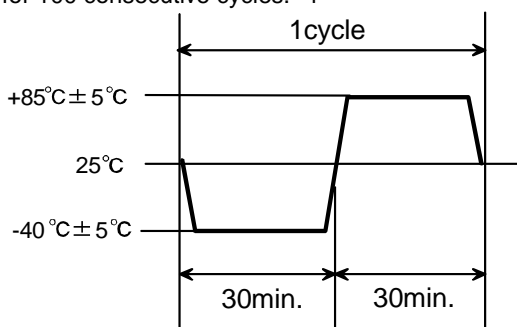
No.	Test Item	Test Methods	Specification Code
1	Drop	Devices are dropped from the height 75cm onto wooden block. (more than 30mm thickness.) Execution 3 times random drops.	A
2	Shock	Devices are shocked to half sine wave (981m/s ²) three mutually perpendicular axis each 3 times.	A
3	Vibration	Frequency Range : 10 to 55 Hz Amplitude : 1.5mm Sweep time : 1 min. Test time : 2.0 hours	A
4	Electrode adherent strength	Reflow soldering shall be used for soldering on test fixture (Glass fiber epoxy laminate : Thickness 1.6mm+/-0.2mm) shown below. (220~240°C) Be careful to happen the heat shock. 	B
5	Solderability	Pre-heat temperature : 150°C Pre-heat Time : 60~120sec. Peek temperature : 240±5°C Soldering temperature : Over 215°C Test time : 10~30 sec.	C
6	Resistance to soldering heat	Pre-heat temperature : 150 °C Pre-heat time : 60 ~ 120sec. Test temperature : 260 ± 5 °C Test time : 10 sec. Max.	A, B
7	Resistance to cold	Leave at -40°C ± 2 °C for 500 hours.	A
8	Resistance to heat	Leave at +85°C ± 2 °C for 500 hours. *1	A
9	Humidity	Devices are left in temperature at +60°C with relative humidity of 90~95% for 500 hours.	A, D
10	Thermal shock	Devices are left into the following temperature cycle as shown in (Figure 1) for 100 consecutive cycles. *1 	A, B

***1. Resistance to heat and Thermal shock**

In case of spec on High temperature exceed +85°C, above test according to spec high temperature will be perform and guarantee.

Specification code	Specification
A	Frequency tolerance and series resistance should be cleared.
B	After testing unless cracking of materials view of eyes and unless break of seal.
C	The leads shall acquire a new solder coat cover at 90% of immersed area.
D	Insulation resistance shall be greater than 500MΩ

Recommendation reflow condition

1.IR reflow condition

