

**RoHS Compliant**  
Directive 2011/65/EU

## SPECIFICATION

Customer: \_\_\_\_\_

Item:	CRYSTAL UNIT
Type:	NX3215SA
Nominal Frequency:	32.768 kHz
Customer's Spec. No.:	STD-MUA-14
NDK Spec. No.:	EXS00A-MU00238

Receipt

Charge:

Sales	NDK ITALY SRL : Paola Bandera	Tel. 39-(0)2-9670292	Approved	H.Matsudo
Engineer	Engineering Dept.1 : Y.Hasuike	Tel. 81-(0)4-2900-6632	Checked	---
			Drawn	Y.Hasuike

### Revision Record

Rev.	Rev. Date	Items	Contents	Remarks
---	21.Mar.2012	Issue	---	---

1. Customer specifications number : 665.100.075.000
2. NDK specification number : EXS00A-MU00238
3. Type : NX3215SA
4. Electrical characteristics
- 4.1. Nominal Frequency ( $F_0$ ) : 32.768 kHz
- 4.2. Overtone Order : Fundamental
- 4.3. Adjustment Tolerance :  $\pm 20 \times 10^{-6}$  Max. (at + 25 °C )
- 4.4. Turning Point : + 25°C  $\pm$  5°C
- 4.5. Temperature coefficient :  $-0.04 \times 10^{-6} / ^\circ\text{C}^2$  Max.
- 4.6. Equivalent resistance ( $R_1$ ) : 70 k $\Omega$  Max.
- 4.7. Shunt capacitance ( $C_0$ ) :  $1.0 \pm 0.5$  pF
- 4.8. Motional capacitance ( $C_1$ ) :  $4.6 \pm 2.0$  fF
- 4.9. Motional Inductance ( $L_1$ ) :  $5080 \pm 1000$  H
- 4.10. Quality Factor (Q) : 15 K to 40 K
- 4.11. Pulling Sensitivity (PS) : 46.0 ppm/pF  $\pm$ 10% (at 6 pF)  
 This value is calculated by following formula.  

$$\text{Pullingsensitivity (PS) [ppm/pF]} = \frac{C_1 \times 1000}{2(C_0 + C_L)^2}$$
  
 Unit  $C_0$ :pF  $C_1$ :fF,  $C_L$ :pF
- 4.12. Insulation resistance : Terminal to terminal insulation resistance  
 also terminal to cover insulation resistance  
 must be 500M $\Omega$  (min) when DC100V  $\pm$ 15V  
 is applied.
5. Measurement circuit
- 5.1. Frequency measurement
- Measuring instrument : Network Analyzer (CNA-LF made in Transat corp.)
  - Load capacitance : 6.0 pF
  - Level of drive : 0.1  $\mu$ W
- 5.2. Equivalent resistance measurement
- Measuring instrument : Network Analyzer (CNA-LF made in Transat corp.)
  - Load capacitance : Series
  - Level of drive : 0.1  $\mu$ W
6. Other performances
- 6.1. Operating temperature range : - 40 to + 85 °C
- 6.2. Storage Temperature range : - 40 to + 85 °C
- 6.3. Maximum Drive Level : 0.5  $\mu$ W Max.
- 6.4. Aging (at +25 °C) :  $\pm 3 \times 10^{-6}$  Max. / 1 year  
 $\pm 7 \times 10^{-6}$  Max. / 5 years  
 $\pm 15 \times 10^{-6}$  Max. / 10 years

7. Examination results document

Since a performance is guaranteed, an examination results document does not submit.

8. Application drawing

8.1. External dimension	: EXD14B-00462
8.2. Taping and reel figure	: EXK17B-00302
8.3. Packaging figure	: EXK17B-00130
8.4. Packing Level	: EXK17B-00213
8.5. Marking Drawing	: EXH11B-00422
8.6. Reliability assurance item	: EXS30B-00661

9. Notice

- 9.1. Order items are manufactured according to specification. As to conditions, which are not indicated in this specification and unpredictable such as applied condition and oscillation margin, please check them beforehand.
- 9.2. Unless we receive request for modification within 3 weeks from the issue date of this NDK specification sheet, we will supply products according to this specification. Also, if you'd like to modify specification of order, which has been placed with delivery request within 3 weeks from the issue data of this specification sheet, we would like to discuss with you separately.
- 9.3. In no event shall the company be liable for any product failure resulting from an inappropriate handling or operation of the product beyond the scope of its guarantee.
- 9.4. Where any change to the process condition is made due to the change(s) in the production line, inform personnel of the specifications.
- 9.5. Should this specification data give rise to any disputes relating to any intellectual property rights or any other rights of a third person, the company shall not indemnify anyone for any damage. Their disclosure must not be construed as the grant of a license to use any of the intellectual property rights owned by the company.
- 9.6. If you intend to use products listed on this specification for applications that may result in loss of life or assets (controls relating to safety, medical equipment, aeronautical equipment, space equipment, etc.), please do not fail to advise us of your intention beforehand.
- 9.7. In the company's production process whatever amount of ozone depleting substances (ODS) as specified in the Montreal protocol is not used.
- 9.8. Information contained in this specification must not be quoted, reproduced or used for other purposes including processing either in part or in full without obtaining prior approval from the company.

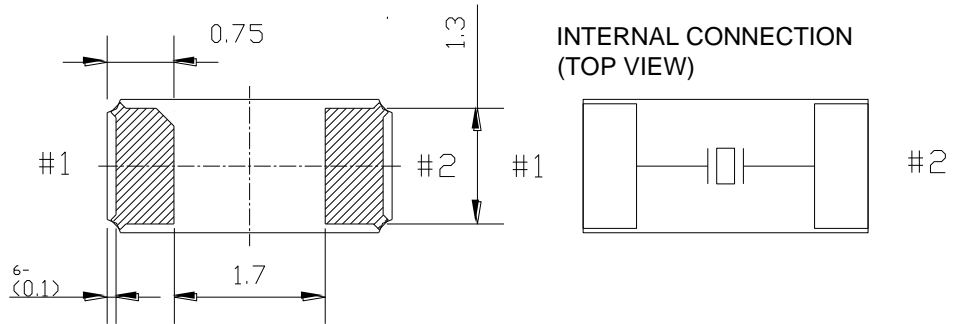
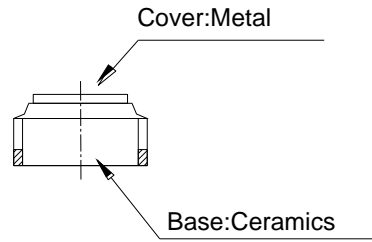
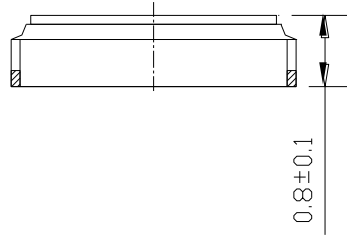
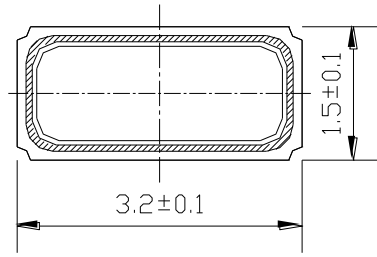

Recommended soldering pattern

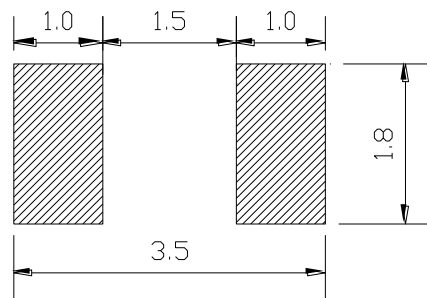

	Date of Revise	Charge	Approved	Reason
A	18.Dec.2009	Miyahara	K.Ueki	Add bilingual
	Date	Name	Third Angle Projection	Tolerance
Drawn	30.Aug.2009	Miyahara	単位:mm	$\pm 0.2$
Designed	30.Aug.2009	Miyahara	Title	Scale
Checked	---	---	NX3215SA External Dimension	10 / 1
Approved	30.Aug.2009	K. Ueki		Rev.
			Drawing No.	A
			EXD14B-00462	

NIHON Dempa Kogyo Co., Ltd.

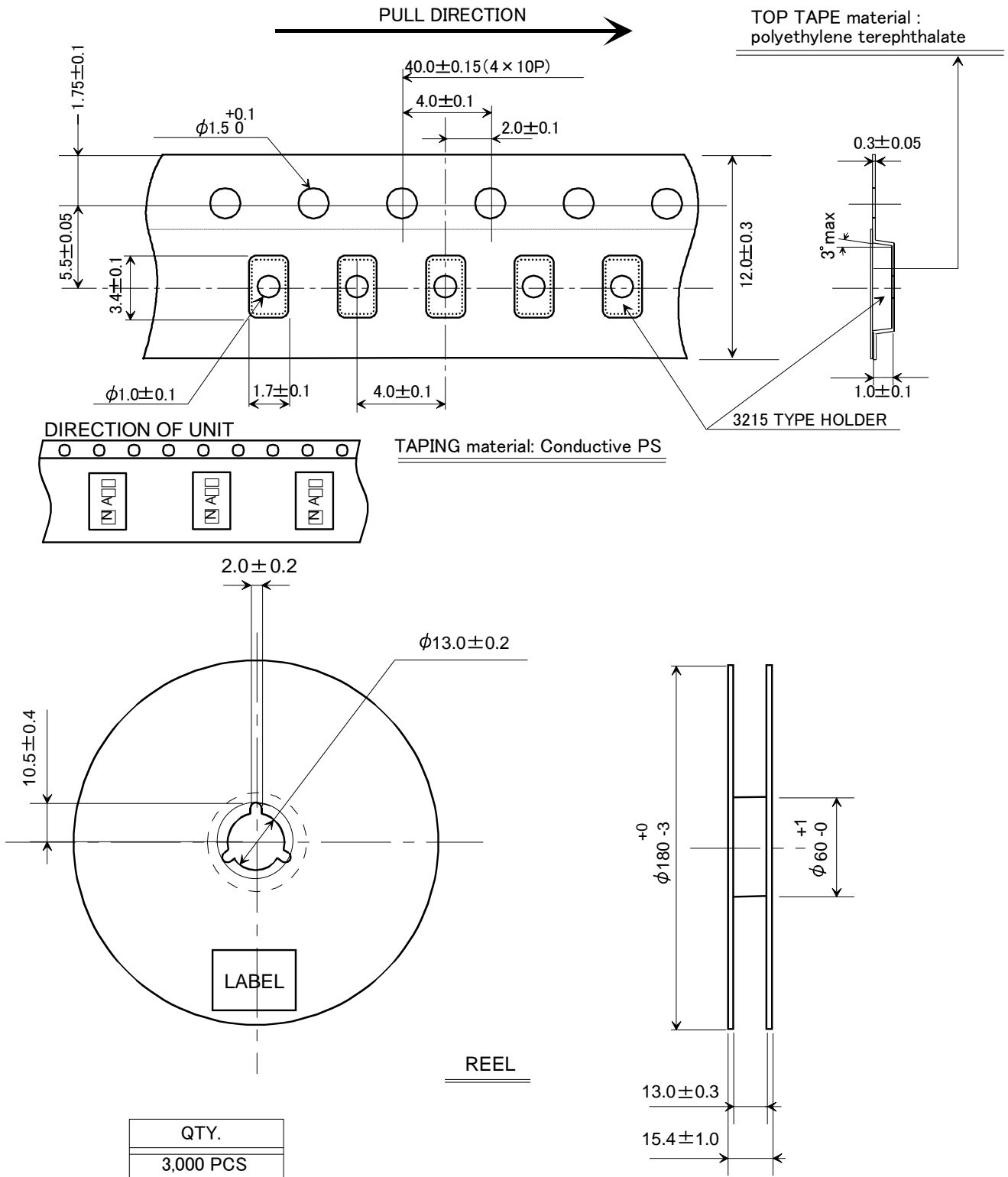

Date of Revise		Charge	Approved	Reason
Drawn	23.Jun.2009	Miyahara	Third Angle Projection Dimension:mm	Tolerance Scale /
Designed	23.Jun.2009	Miyahara	Title <b>Tape and Reel Spec.</b>	Drawing No. <b>EXK17B-00302</b>
Checked	---	---		
Approved	23.Jun.2009	K. Ueki		

**NIHON DEMPA KOGYO CO., LTD.**

For 8 and 12mm width carrier tape

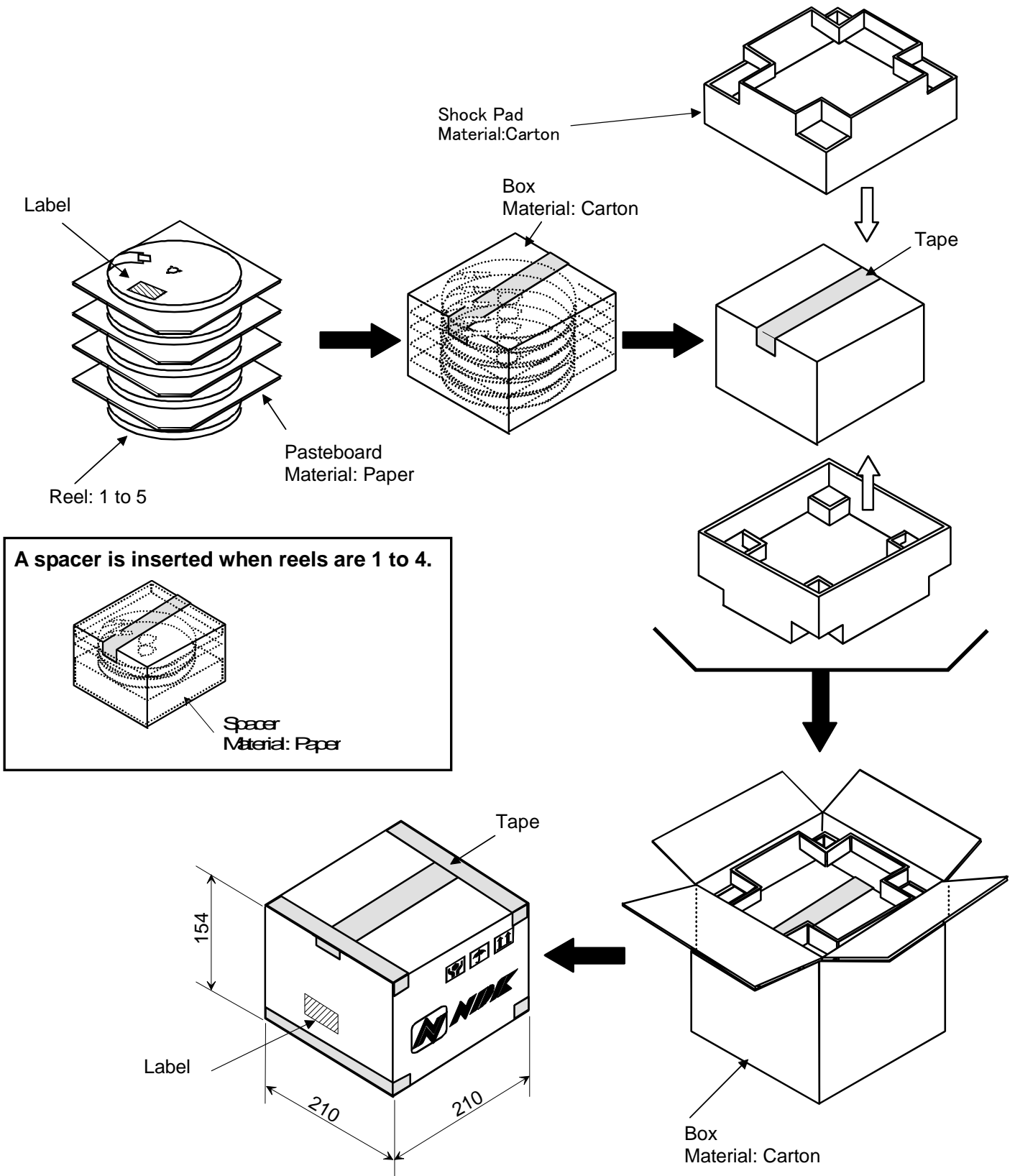

	Date of Revise	Charge	Approved	Reason		
B	30 Jun. 2008	K. Oguri	K. Miyashita	The pasting method of shipping tape was corrected.		
	Date	Name	Third Angle Projection	Tolerance		
Drawn	9.Aug.2002	K.Oguri	Dimension:mm	Scale		
Designed	9.Aug.2002	K.Oguri	Title	Drawing No.		
Checked	-----	-----			180mm reel Packing	EXK17B-00130
Approved	9.Aug.2002	K.Miyashita				
				B		

**NIHON DEMPA KOGYO CO., LTD.**

LABEL SIZE: 76×50mm

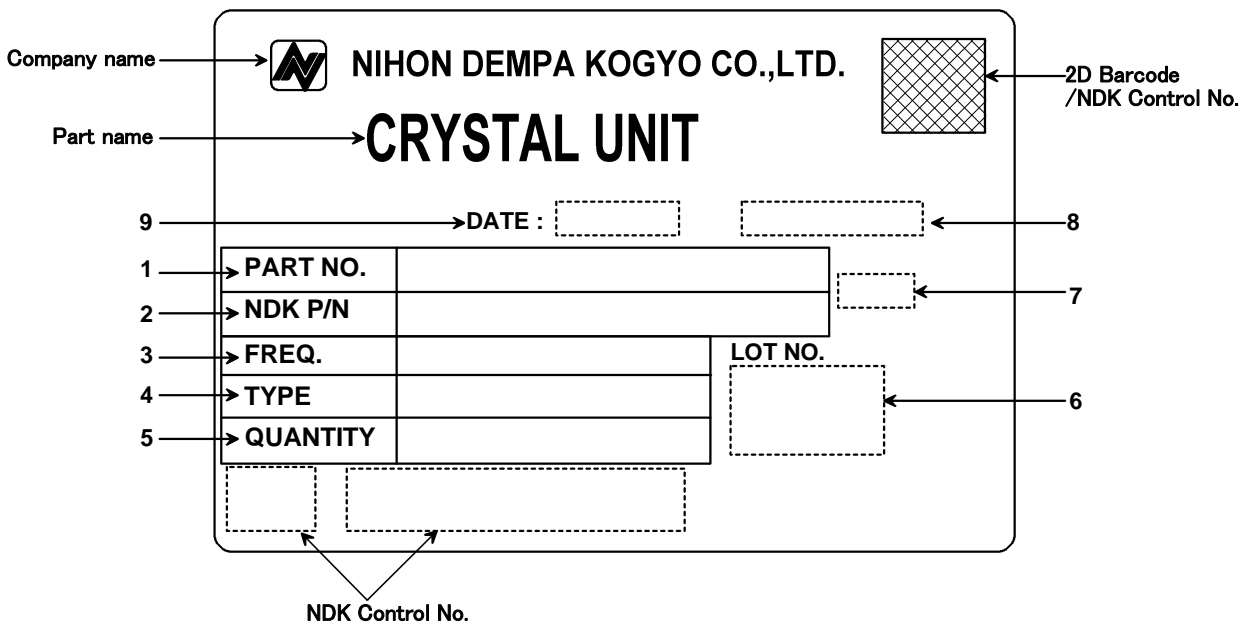

No.	Marking Item	Marking Contents
<b>1</b>	PART NO.	Customer's Part Number
<b>2</b>	NDK P/N	NDK Part Number
<b>3</b>	FREQ.	Frequency
<b>4</b>	TYPE	NDK Type name
<b>5</b>	QUANTITY	Total quantity
<b>6</b>	LOT NO.	* Lot No.: A lot marking indicated on the product (EIA code, Lot No., etc.) * Marking Method : Lot No.-QTY. Example of mixed 2 lots.; 54-1000pcs , 55-1000pcs
<b>7</b>	OTHERS	The marking corresponded to ROHS * The "ROHS" is indicated for products corresponded to ROHS.
<b>8</b>	COUNTRY OF ORIGIN	Country of Origin
<b>9</b>	DATE	Production date DD/MM/YYYY

	Date of Revise	Charge	Approved	Reason	
C	15 May 2008	T. Shimizu	K. Miyashita	No. 8 and 9 were added.	
	Date	Name	Third Angle Projection	Tolerance	Scale
Drawn	13.May.2005	K.Oguri	Dimension:mm	-----	-----
Designed	13.May.2005	K.Oguri	Title	Drawing No.	Rev.
Checked	-----	-----			
Approved	13.May.2005	K. Miyashita			
			<b>Packing Label</b>	<b>EXK17B-00213</b>	<b>C</b>

**NIHON DEMPA KOGYO CO., LTD.**

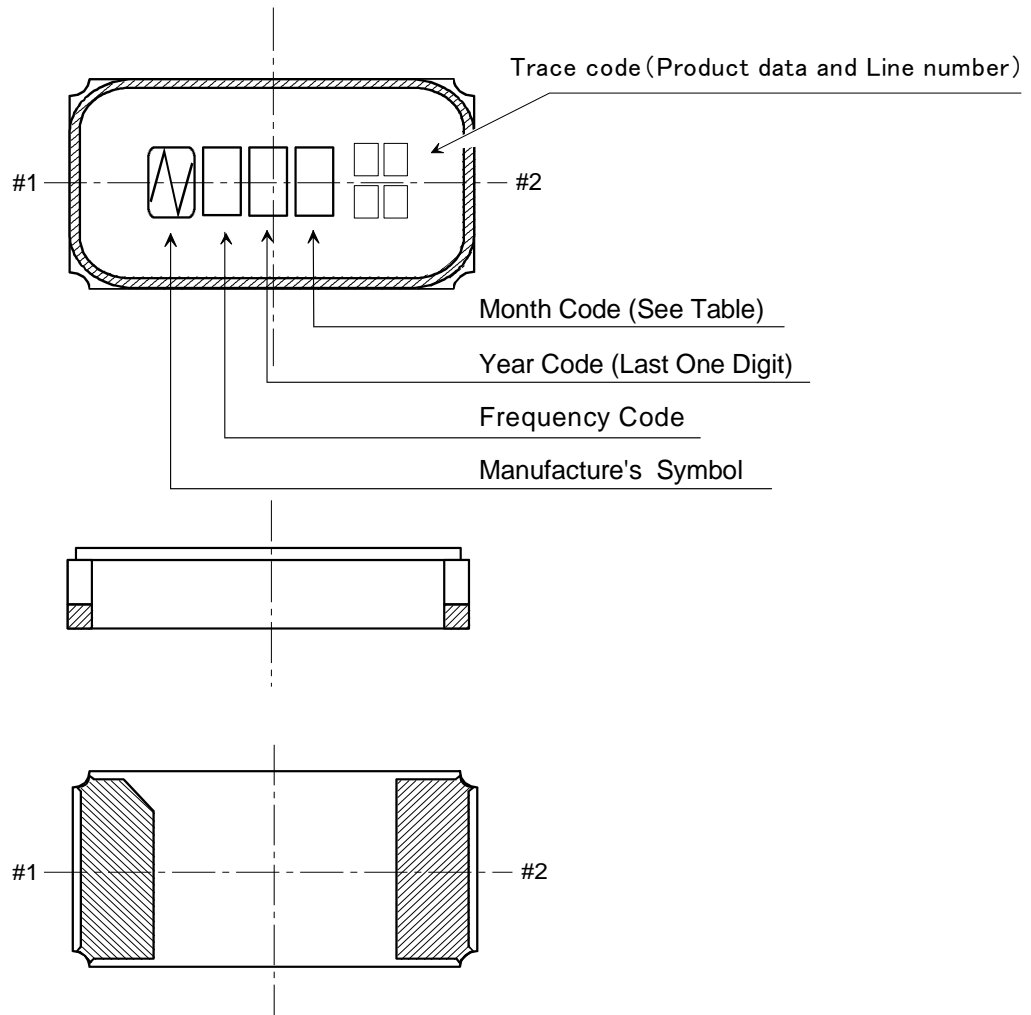

NOTE

1. Month Code

Month	1 Jan.	2 Feb.	3 Mar.	4 Apr.	5 May	6 June	7 July	8 Aug.	9 Sep.	10 Oct.	11 Nov.	12 Dec.
Month Code	1	2	3	4	5	6	7	8	9	X	Y	Z

2. Frequency Code

A : 32.768kHz

3. Marking Method

Marking Method is Laser Trimming.

	Date of Revise	Charge	Approved	Reason		
	Date	Name	Third Angle Projection	Tolerance	Scale	
Drawn	28.Oct.2009	Miyahara	Dimension:mm		/	
Designed	28.Oct.2009	Miyahara	Title <b>NX3215SA Marking Drawing</b>	Drawing No. <b>EXH11B-00422</b>	Rev.	
Checked	--	--				
Approved	28.Oct.2009	Ueki				

**NIHON DEMPA KOGYO CO., LTD.**

**Reliability assurance item**

(page: 1/2)

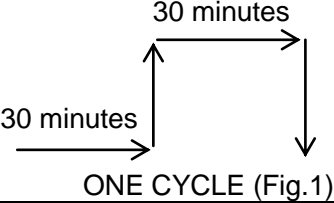
No.	Test Item	Test Methods	Specification Code
1	AGING	1 year at 25 °C +/- 3°C	a
2	COLD RESISTANCE	at -40 °C for 500 hours.	a
3	HUMIDITY	at +85 °C with 80 to 85 % RH for 500 hours.	a
4	THERMAL SHOCK	Temperature cycle as shown in (Fig.1) for 100 cycle. 	a
5	VIBRATION	Frequency Range : 10 to 2000Hz Amplitude or Acceleration : 1.52 mm or 20 G 1 cycle : 20 minutes Test time : Three mutually perpendicular axes each 12 times.	a
6	SHOCK 1	Shock : 3000 Gs 0.3 msec. Test time : Six mutually perpendicular axes each 1 times.	a
7	SHOCK 2	Shock : Device are put on the weight of 200 g and dropped on concrete board. Height : 1.5 m Drop times : Six mutually perpendicular axes each 10 times.	b
8	SOLDERABILITY	Residual heat temperature 150 °C Residual heat time 60 to 120 sec Peak temperature 240°C (more than 215 °C 10 to 30 sec)	c
9	REFLOW RESISTANCE	Temperature cycle as shown in (Fig2.) for 3 cycle.	a

Specification code	Specification
a	dF/F ≤ +/- 5ppm dCl ≤ +/- 5 kohm
b	dF/F ≤ +/- 15ppm dCl ≤ +/- 5 kohm
c	The electrodes shall acquire a new solder coat over at least 90 % of immersed area.

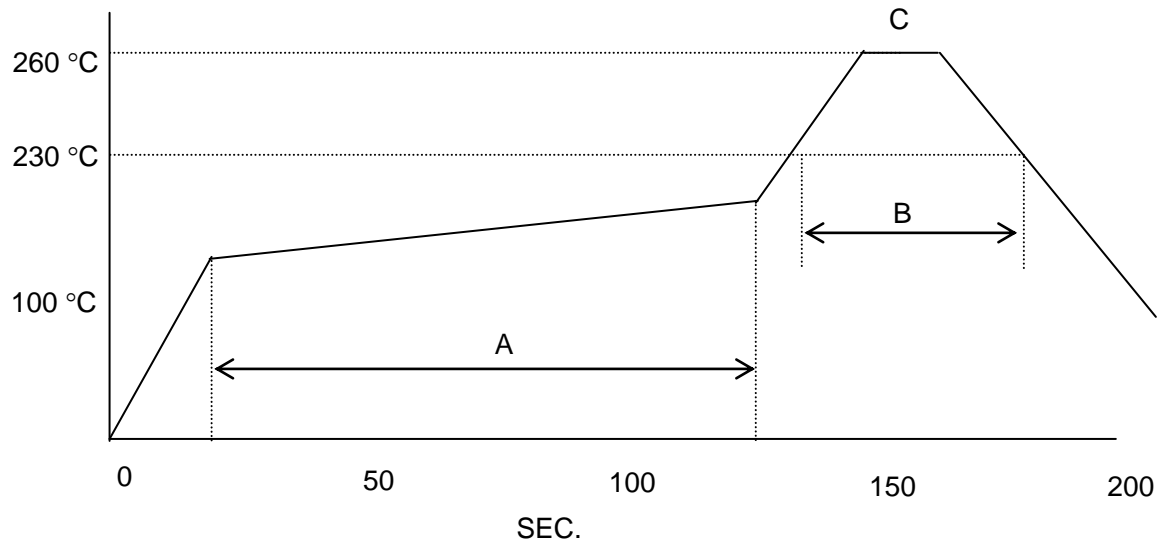

Fig.2 REFLOW

- A: 150 to 180 °C ( 60 to 120 sec. )
- B: 230 °C min. ( 30 sec. max. )
- C: PEAK-TEMP. 260 °C +/- 5 °C ( 10sec. max. )