



RoHS Compliant
Directive 2011/65/EU

SPECIFICATION

Customer: _____

Item: _____ Crystal Unit

Type: _____ NX2016SA

Nominal frequency: _____ 38.400 MHz

Customer's Spec. No.: _____ ---

NDK Spec. No.: _____ EXS00A-CS08973

Receipt

Charge:

| | | |
|----------|---------------------------------------|--|
| Sales | T NDK -F David MAUREL | Tel : 33-1-60-95-0000 Mail: dmaurel@fr.ndk.com |
| Engineer | 1 st Eng. Dept. Tsukumo | Tel. : (81)-4-2900-6653 e-Mail : tukumo@ndk.com |

Revision Record

| Rev. | Date | Items | Contents | Approved | Checked | Drawn |
|------|-------------|----------|----------|----------|---------|---------|
| --- | 15.May.2015 | Issue | --- | Miyahara | --- | Tsukumo |
| | 17.Oct.2019 | Rev Temp | | | | |

1. Customer's Spec. No. : ---
2. NDK Spec. No. : EXS00A-CS08973
3. Type : NX2016SA

4. Electrical Specifications

| | Parameters | SYM. | Electrical Spec. | | | | Notes |
|----|--|-----------|------------------|------|----------------------|----------------------|---|
| | | | min | typ | max | Units | |
| 1 | Nominal frequency | f_{nom} | 38.400 | | | MHz | |
| 2 | Overtone order | - | Fundamental | | | - | |
| 3 | Frequency tolerance | - | -10 | - | +10 | ppm | at +25°C |
| 4 | Frequency versus temperature characteristics | - | -12 | - | +12 | ppm | at -40~+85°C The reference temperature shall be +25°C |
| 5 | Equivalent resistance | - | - | - | 60 | Ω | IEC π -Network Series |
| 6 | Shunt capacitance | C_0 | -30% | 0.61 | +30% | pF | Cover grounded |
| 7 | Motional capacitance | C_1 | -30% | 2.05 | +30% | fF | Cover grounded |
| 8 | Motional inductance | L_1 | -30% | 8.39 | +30% | mH | Cover grounded |
| 9 | Load capacitance | C_L | - | 10 | - | pF | IEC π -Network |
| 10 | Level of drive | - | - | 10 | 200 | μ W | |
| 11 | Insulation resistance | - | 500 | - | - | M Ω | When terminal to terminal and terminal to cover were applied at DC100V \pm 15V. |
| 12 | Operating temperature range | - | -40 | - | +85 | °C | |
| 13 | Storage temperature range | - | -40 | - | +85 | °C | |
| 14 | Recommended oscillation margin | - | 400 | - | - | Ω | When the circuit does not have enough value as above, please contact us. |
| 15 | Air-tightness | - | - | - | 1.1×10^{-9} | Pa m ³ /s | Helium leak detector |

5. Examination results document

Since a performance is guaranteed, an examination results document does not submit.

6. Application drawing

- 6.1 External dimension : EXD14B-00467
- 6.2 Taping and reel figure : EXK17B-00200
- 6.3 Packing : EEK17B-00015
- 6.4 Holder marking : EXH11B-00317
- 6.5 Packing Label : EXK17B-00213
- 6.6 Reliability assurance Item : EXS30B-00250

7. Notice

- 7.1 Order items are manufactured according to specification. As to conditions, which are not indicated in this specification and unpredictable such as applied condition and oscillation margin, please check them beforehand.
- 7.2 Unless we receive request for modification within 3 weeks from the issue date of this NDK specification sheet, we will supply products according to this specification. Also, if you'd like to modify specification of order, which has been placed with delivery request within 3 weeks from the issue data of this specification sheet, we would like to discuss with you separately.
- 7.3 In no event shall the company be liable for any product failure resulting from an inappropriate handling or operation of the product beyond the scope of its guarantee.
- 7.4 Where any change to the process condition is made due to the change(s) in the production line, inform personnel of the specifications.
- 7.5 Should this specification data give rise to any disputes relating to any intellectual property rights or any other rights of a third person, the company shall not indemnify anyone for any damage. Their disclosure must not be construed as the grant of a license to use any of the intellectual property rights owned by the company.
- 7.6 If you intend to use products listed on this specification for applications that may result in loss of life or assets (controls relating to safety, medical equipment, aeronautical equipment, space equipment, etc.), please do not fail to advise us of your intention beforehand.
- 7.7 In the company's production process whatever amount of ozone depleting substances (ODS) as specified in the Montreal protocol is not used.
- 7.8 Information contained in this specification must not be quoted, reproduced or used for other purposes including processing either in part or in full without obtaining prior approval from the company.
- 7.9 Crystal units will be damaged by ultrasonic welding process due to resonance of crystal wafer itself. NDK does not recommend using ultrasonic welding. If Ultra Sonic welding used, NDK strongly recommend verifying crystal unit damage by ultrasonic weld.
- 7.10 The appearance color has a different case by purchasing it more than 2 suppliers of the component, but characteristic and reliability are guaranteed.
- 7.11 In case of the product long time keep at high temperature and humidity, may affect product characteristic (solder ability) and a packing condition.
Please keep at storage condition of temperature +5°C ~+35°C, humidity ~85%RH.

8. Prohibited items

Be sure to use the product under the following conditions. Otherwise, the characteristics deterioration or destruction of the product may result.

(1) Reflow soldering heat resistance

- Peak temperature: 265°C, 10 sec
- Heating: 230°C or higher, 40 sec
- Preheating: 150°C to 180°C, 120 sec
- Reflow passage times: twice

(2) Manual soldering heat resistance

- Pressing a soldering iron of 400°C on the terminal electrode for four seconds (twice).

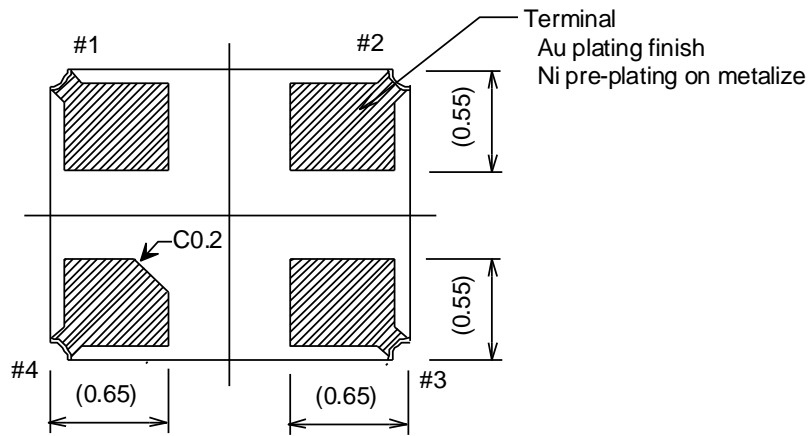
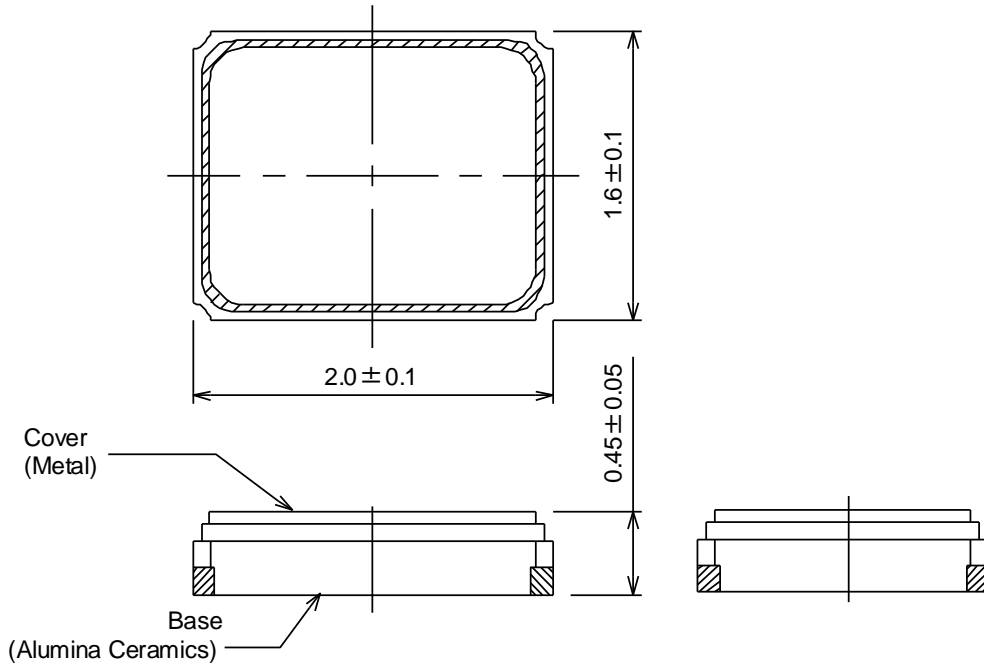

LAND PATTERN (TYPICAL)

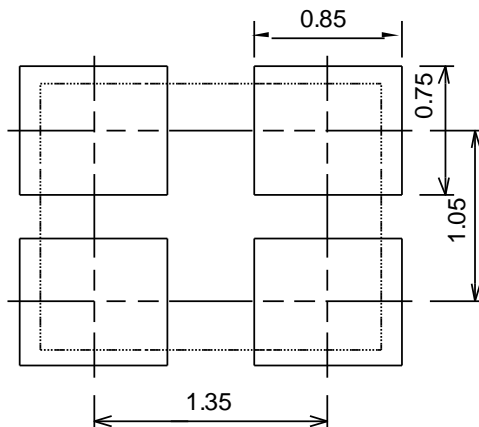

PIN CONNECTION (TOP VIEW)

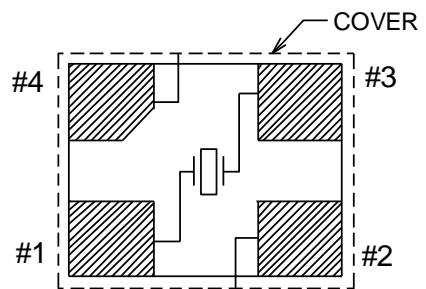

TERMINAL

#1,#3 : XTAL

#2,#4 : GND(CONNECTION WITH COVER)

| | | | | |
|----------|----------------|----------|--------------------------------------|----------------------------|
| | Date of Revise | Charge | Approved | Reason |
| A | 15.Feb.2011 | H.Ouchi | K.Ueki | Index position correction. |
| | Date | Name | Third Angle Projection | Tolerance |
| Drawn | 19.Oct.2009 | M.Harada | Dimension:mm | ---- |
| Designed | 19.Oct.2009 | M.Harada | Title | Drawing No. |
| Checked | --- | --- | NX2016SA Dimension Drawing | EXD14B-00467 |
| Approved | 20.Oct.2009 | K.Ueki | | |
| | | | | A |

NIHON DEMPA KOGYO CO., LTD.

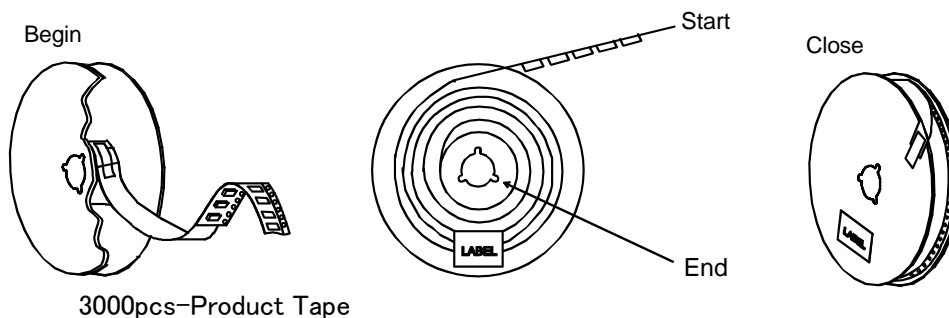
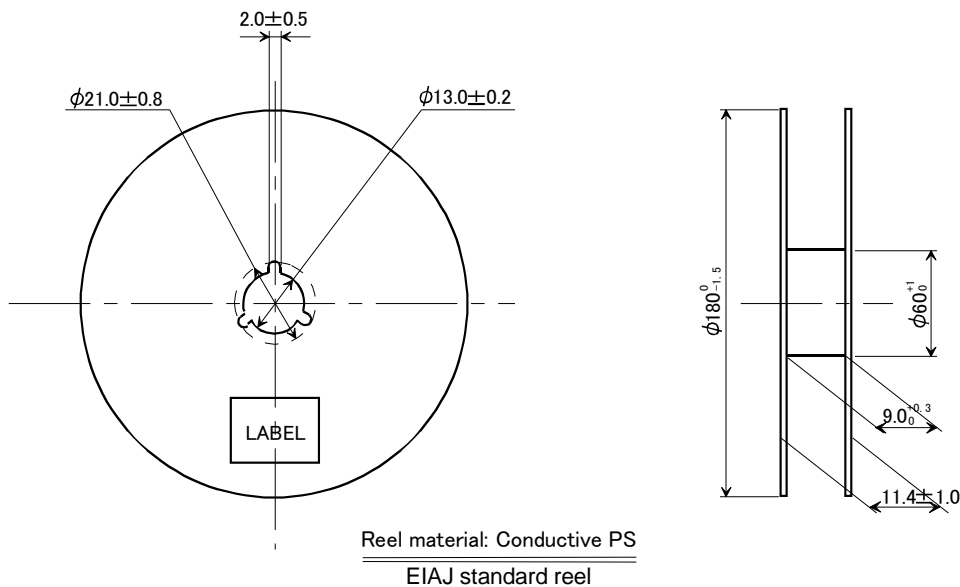
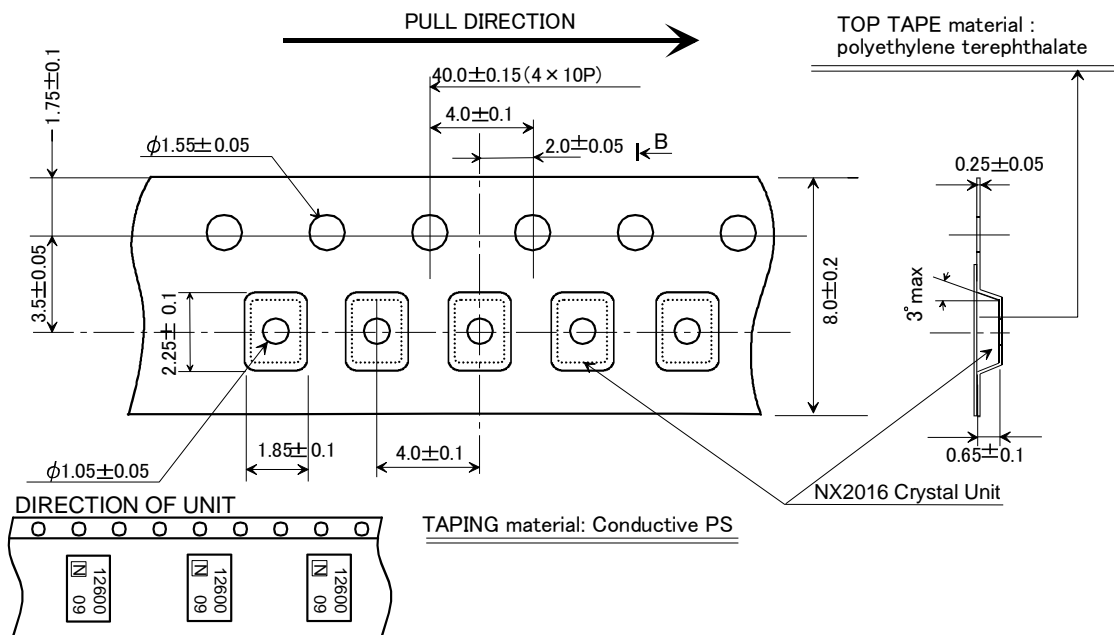

| | | | | | |
|----------|----------------|--------------|---|------------------------------------|------|
| | Date of Revise | Charge | Approved | Reason | |
| A | 26.Nov.2009 | H.Ouchi | K.Ueki | Title change | |
| | Date | Name | Third Angle Projection | Tolerance | |
| Drawn | 12.Apr.2005 | K.Oguri | Dimension:mm | Scale | |
| Designed | 12.Apr.2005 | K.Oguri | Title NX2016 Series Taping and Reel Spec. | Drawing No. EXK17B-00200 | |
| Checked | ----- | ----- | | | Rev. |
| Approved | 12.Apr.2005 | K. Miyashita | | | A |

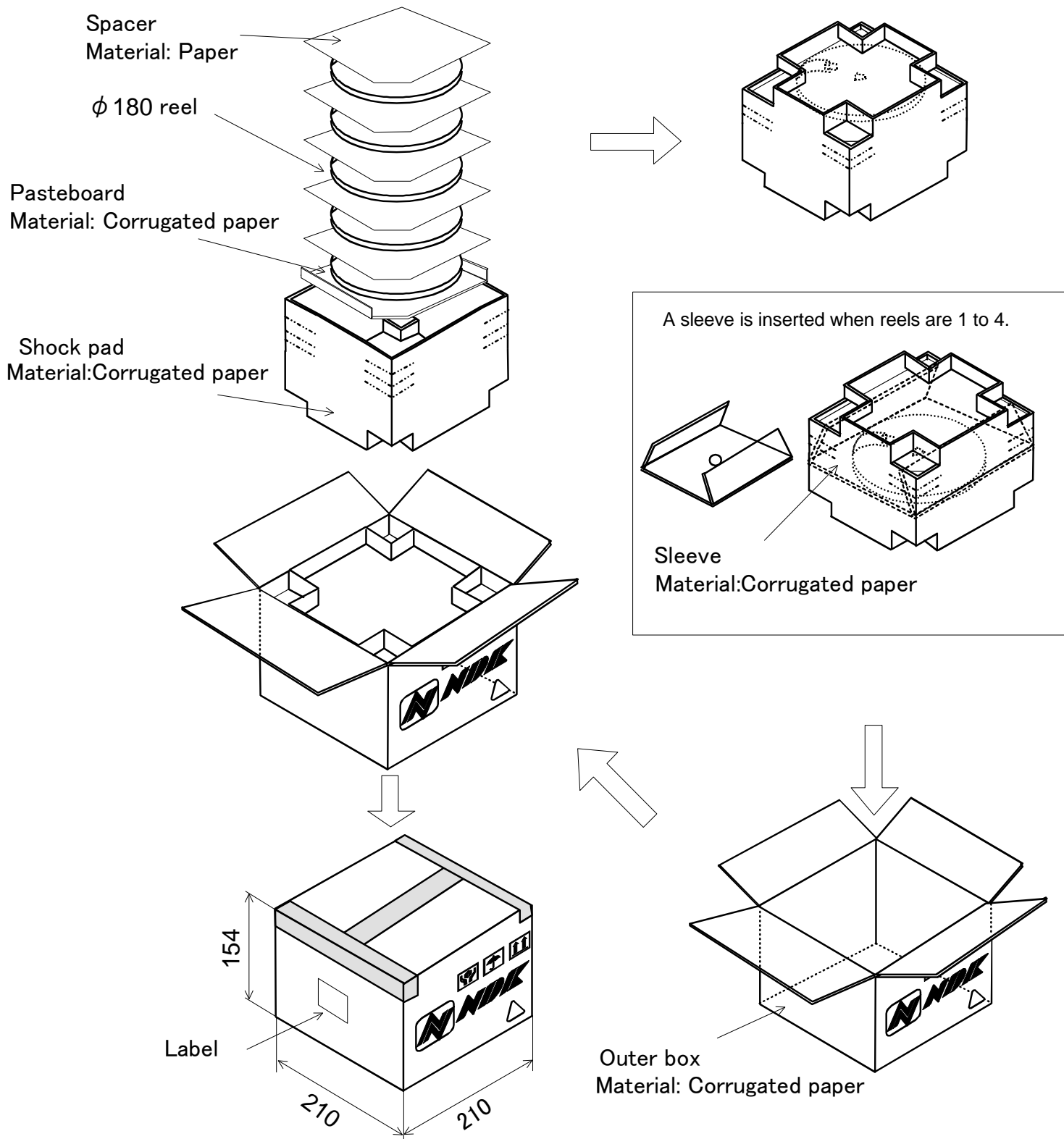

| | | | | |
|----------|----------------|-------------|------------------------------|--|
| | Date of Revise | Charge | Approved | Reason |
| C | 4 Jul. 2012 | H.Ohkubo | K.Oguri | Addition of condition when reels are 1 to 4. |
| | Date | Name | Third Angle Projection | Tolerance |
| Drawn | 26 Feb. 2010 | H. Ohkubo | Dimension:mm | ----- |
| Designed | 26 Feb. 2010 | K.Oguri | Title | Drawing No. |
| Checked | 26 Feb. 2010 | K.Oguri | | |
| Approved | 26 Feb. 2010 | J. Nakamura | 180 dia. Reel package | EEK17B-00015 |
| | | | | C |

NIHON DEMPA KOGYO CO., LTD.

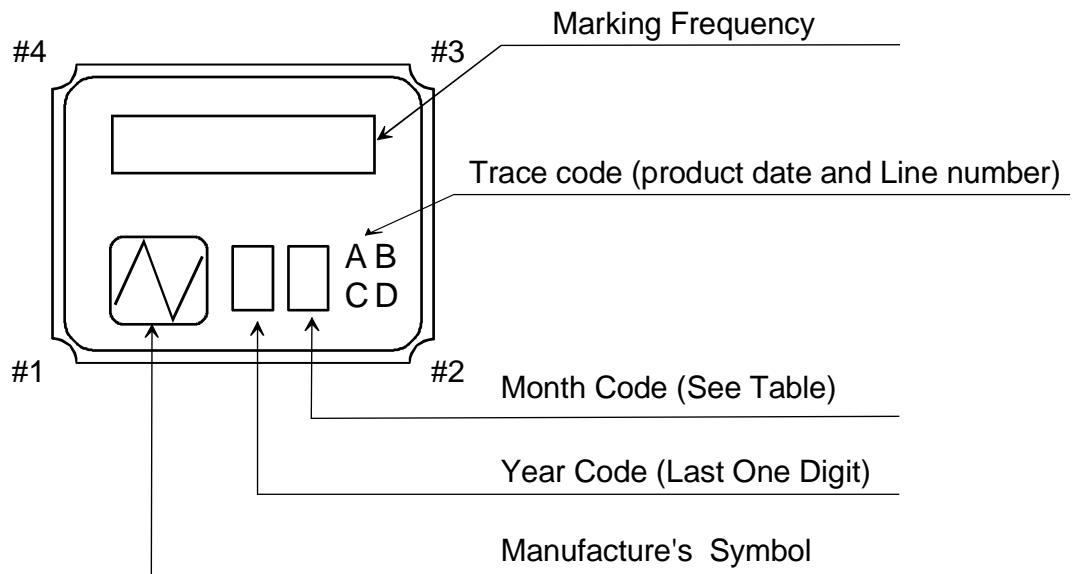

NOTE

1. Frequency Code

Marking Frequency is consist of five digits, first five digits of Nominal Frequency

Example

| | |
|-------------------|---------------|
| Nominal Frequency | 28.636363 MHz |
| Frequency Code | 28.636 |

2. Month Code Table

| Month | 1 Jan. | 2 Feb. | 3 Mar. | 4 Apr. | 5 May. | 6 Jun. | 7 Jul. | 8 Aug. | 9 Sep. | 10 Oct. | 11 Nov. | 12 Dec. |
|------------|-----------|-----------|-----------|-----------|-----------|-----------|-----------|-----------|-----------|------------|------------|------------|
| Month Code | 1 | 2 | 3 | 4 | 5 | 6 | 7 | 8 | 9 | X | Y | Z |

*Marking digits are not include a decimal point and dot mark.

| | | | | | | |
|----------|----------------|------------|-------------------------------|------------------------------------|---------------------|----------|
| | Date of Revise | Charge | Approved | Reason | | |
| D | 10. Dec 2014 | Y.Sakurai | H.Kobayashi | Added terminal number information. | | |
| | Date | Name | Third Angle Projection | Tolerance | Scale | |
| Drawn | 16.Jan.2006 | I.Miyahara | Dimension:mm | | / | |
| Designed | 16.Jan.2006 | I.Miyahara | Title | | Drawing No. | Rev. |
| Checked | 16.Jan.2006 | --- | Crystal Holder Marking | | EXH11B-00317 | D |
| Approved | 16.Jan.2006 | K.Okamoto | | | | |

NIHON DEMPA KOGYO CO., LTD.

LABEL SIZE: 76×50mm

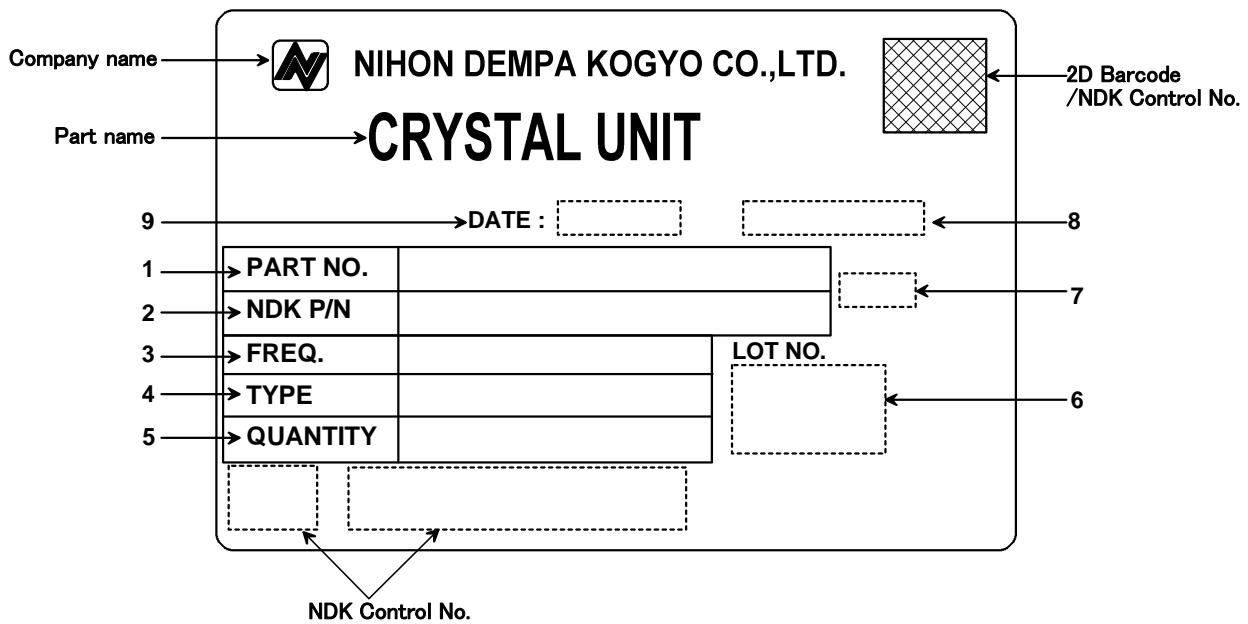

| No. | Marking Item | Marking Contents |
|-----|-------------------|--|
| 1 | PART NO. | Customer's Part Number |
| 2 | NDK P/N | NDK Part Number |
| 3 | FREQ. | Frequency |
| 4 | TYPE | NDK Type name |
| 5 | QUANTITY | Total quantity |
| 6 | LOT NO. | * Lot No.: A lot marking indicated on the product (EIA code, Lot No., etc.) * Marking Method : Lot No.-QTY. Example of mixed 2 lots.; 54-1000pcs , 55-1000pcs |
| 7 | OTHERS | The marking corresponded to ROHS * The "ROHS" is indicated for products corresponded to ROHS. |
| 8 | COUNTRY OF ORIGIN | Country of Origin |
| 9 | DATE | Production date DD/MM/YYYY |

| | | | | | |
|----------|----------------|--------------|------------------------|-------------------------|----------|
| | Date of Revise | Charge | Approved | Reason | |
| C | 15 May 2008 | T. Shimizu | K. Miyashita | No. 8 and 9 were added. | |
| | Date | Name | Third Angle Projection | Tolerance | Scale |
| Drawn | 13.May.2005 | K.Oguri | Dimension:mm | ----- | ----- |
| Designed | 13.May.2005 | K.Oguri | Title | Drawing No. | Rev. |
| Checked | ----- | ----- | | | |
| Approved | 13.May.2005 | K. Miyashita | | | |
| | | | Packing Label | EXK17B-00213 | C |

NIHON DEMPA KOGYO CO., LTD.

Reliability assurance item

(page: 1/1)

| No. | Test Item | Test Methods | Spec. Code |
|-----|--------------------------|--|------------|
| 1 | High Temperature Storage | +85±3°C 720h | A |
| 2 | Low Temperature Storage | -40±3°C 500h | A |
| 3 | Temperature Humidity | +85±3°C 80~85%RH 500h | A |
| 4 | Temperature Cycling | -40±3°C / +85±3°C It is 1000 cycles using 30 minutes each as 1 cycle. | A |
| 5 | Vibration | Frequency Range : 10~2000Hz Amplitude or Acceleration : 1.52mm or 196m/s ² 1 cycle : 20 minutes Test time : Three mutually perpendicular axes each 4 hours. | A |
| 6 | Shock | Devices are shocked to half sine wave (29418m/s ² , 0.3msec) six mutually perpendicular axis each 1 times. | A |
| 7 | Drop | Preparation : Test pieces should be fixed on the dummy load with 200g weight. Condition : Height 1.5m onto concrete Drop times : 10 times in 6 mutually perpendicular axes | A |
| 8 | Solderability | Pre-heat temperature : +150±10°C Pre-heat time : 60~120s When the temperature of the specimen is reached at +215±3°C, it shall be left for 30±1sec. Peak temperature 240±5°C Material: Pb-free (Sn-3.0Ag-0.5Cu) Flux : Rosin resin methyl alcohol solvent (1 : 4) | B |
| 9 | Reflow resistance | Pre-heat temperature : +150~180°C Pre-heat time : 90±30s Heat temperature : more than +230°C Heat time : 30s ±10s Peak temperature : +260±5°C Peak time : less than 10s | A |

| Specification code | Specification |
|--------------------|---|
| A | $\Delta f/f \leq \pm 3$ ppm $\Delta Cl/Cl \leq \pm 15$ % or 5 Ω make use larger value |
| B | The electrodes should be covered by a new solder at least 90% of immersed area. |