

**RoHS Compliant**  
Directive 2011/65/EU

## SPECIFICATION

Customer: \_\_\_\_\_

Item:	Crystal Oscillator
Type:	NT7050BC
Nominal Frequency:	19.440 MHz
Customer's Spec. No.:	-----
NDK Spec. No.:	END4053B

Receipt

Charge:

Sales	NDK-I Alessia Meroni	Tel. + 39-02-96702920	Approved	Y.Yokozeki
Engineer	Engineering Dept.2 Naoki Sekine	Tel. +81 4 2900 6619	Checked	-----
			Drawn	N.Sekine

### Revision Record

Rev.	Rev. Date	Items	Contents	Remarks
-----	29.Sep.2011	Issue		

This is specification of Temperature compensated crystal oscillator.

1. Customer's Spec. No.  
-----
2. Type  
NT7050BC
3. NDK Spec. No.  
END4053B
4. External Dimension  
ETD14B-01491
5. Rating
  - 5.1 Nominal Frequency (f0)  
19.440 MHz
  - 5.2 Supply Voltage (VCC)  
+3.3V±5%
  - 5.3 Load (CL)  
15 pF
  - 5.4 Operating Temp. Range (TOPR)  
-40 to +90°C
  - 5.5 Storage Temp. Range (TSTG)  
-55 to +125°C

#### 6. Electrical Specification

Unless otherwise specified, measuring condition T = +25°C, VCC = +3.3V, CL = 15pF

	Item	Symbol	Condition	Rating		Unit	
				Min.	Max.		
6.1	Current Consumption	ICC	-	-	6	mA	
6.2	Frequency Stability		Overall	-4.6	+4.6	ppm	
	6.2.1 Tolerance	dF/Fo	(*1)	-1.0	+1.0	ppm	
	6.2.2 Vs. Temperature	dF/F	-40 to +90°C (*2)	-0.28	+0.28	ppm	
	6.2.3 Vs. Supply Voltage	dF/F	+3.3 V ±5%	-0.1	+0.1	ppm	
	6.2.4 Vs. Load	dF/F	15 pF ± 5pF	-0.1	+0.1	ppm	
	6.2.4 Vs. Aging		dF/F	24H (*2)	-0.01	+0.01	ppm
				1year (*2)	-1.0	+1.0	ppm
10years (*2)				-3.0	+3.0	ppm	
6.3	Output		Square Wave				
	6.3.1 Output Level (C-MOS)	VOL		-	0.1 Vcc	V	
		VOH		0.9 Vcc	-	V	
	6.3.2 Duty cycle	tw / t	@0.5 Vcc	45	55	%	
6.3.3 Rise time, Fall time	tr / tf	10 % to 90 %, 90% to 10%		9	ns		
6.4	Phase Noise		10 Hz		-85	dBc/Hz	
			100 Hz		-110	dBc/Hz	
			1 kHz		-125	dBc/Hz	
			10 kHz		-135	dBc/Hz	
6.5	Enable/Disable function		No connection	Enable Output		-	
			VIH ≥ 70% of VCC	Enable Output		-	
			VIL ≤ 30% of VCC	Disable Output		-	

(\*1)dF/Fo: Frequency shift at T=+25°C, VCC =+3.3V, CL =15pF in reference to Nominal frequency (fo)

(\*2)dF/F: Frequency shift from the reference frequency at T=+25°C, VCC =+3.3V, CL =15pF

(\*3)REF V: When you do not use it, please do not connect.

## 7. Crystal Oscillator Reliability Guarantee Item

Test Item	Test Methods	Specification
1. Vibration	IEC68-2-6, test Fc 10 to 60Hz, 98.1m/s <sup>2</sup> 0.5 h, 3 direction.	Shall meet electrical specification.
2. Shock	IEC68-2-27, test Ea 981m/s <sup>2</sup> , 6ms, Half Sine, 3 bumps, 6 directions.	Shall meet electrical specification

## 8. Inspection Parameters

Clause 4, 5.1, 6.1, 6.2.1, 6.2.2, 6.3.1, 6.3.2

## 9. Guarantee Parameters

Clause 6.2.3, 6.2.4, 6.3.3, 6.4, 6.5, 6.6, 7

## 10. Marking

1. Model
2. Frequency
3. Dot
4. NDK Symbol Mark
5. Lot

## 11. Notice

- 11.1 Order items are manufactured according to specification. As to conditions, which are not indicated in this specification and unpredictable such as applied condition and oscillation margin, please check them beforehand.
- 11.2 Unless we receive request for modification within 3 weeks from the issue date of this NDK specification sheet, we will supply products according to this specification. Also, if you'd like to modify specification of order, which has been placed with delivery request within 3 weeks from the issue data of this specification sheet, we would like to discuss with you separately.
- 11.3 In no event shall the company be liable for any product failure resulting from an inappropriate handling or operation of the product beyond the scope of its guarantee.
- 11.4 Where any change to the process condition is made due to the change(s) in the production line, inform personnel of the specifications.
- 11.5 Should this specification data give rise to any disputes relating to any intellectual property rights or any other rights of a third person, the company shall not indemnify anyone for any damage. Their disclosure must not be construed as the grant of a license to use any of the intellectual property rights owned by the company.
- 11.6 If you intend to use products listed on this specification for applications that may result in loss of life or assets (controls relating to safety, medical equipment, aeronautical equipment, space equipment, etc.), please do not fail to advise us of your intention beforehand.
- 11.7 In the company's production process whatever amount of ozone depleting substances (ODS) as specified in the Montreal protocol is not used.
- 11.8 Information contained in this specification must not be quoted, reproduced or used for other purposes including processing either in part or in full without obtaining prior approval from the company.

12. Prohibited items

Be sure to use the product under the following conditions. Otherwise, the characteristics deterioration or destruction of the product may result.

(1) Reflow soldering heat resistance

Peak temperature: 260°C, 10 sec

Heating: 225°C or higher, 30 sec

Preheating: 150°C to 180°C, 120 sec

Reflow passage times: twice

In reflowing, the turning over of mounted boards shall be forbidden.

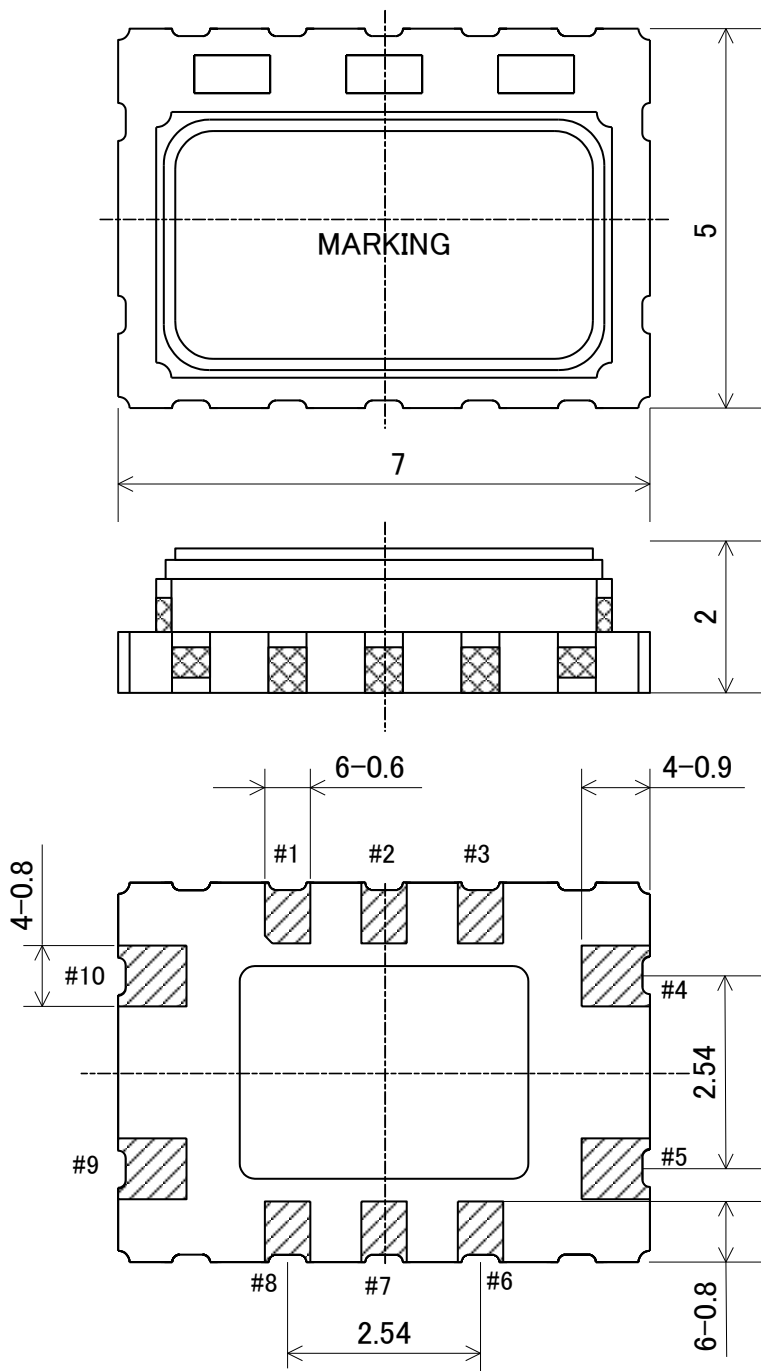

**Terminal land connections**

#1	Do not connect	*1
#2	NC	
#3	NC	
#4	GND	
#5	OUTPUT	
#6	Do not connect	*1
#7	NC	
#8	Enable/Disable	
#9	VCC	*2
#10	Do not connect	*1

\*1 Please do not connect with terminal.

\*2 Please connect a 0.01 uF bypass capacitor near the VCC terminal.

Date of Revise	Charge	Approved	Reason
A			
Drawn	Date: 7.May.2011 Name: N.Sekine	Third Angle Projection Dimension: mm	Tolerance: ±0.2 Scale: 10/1
Designed	7.May.2011 N.Sekine	Title: <b>External Dimension</b>	Drawing No.: <b>ETD14B-01491</b>
Checked	-----		
Approved	7.May.2011 Y.Yokozeki		
		Rev.	

**NIHON DEMPA KOGYO CO., LTD.**

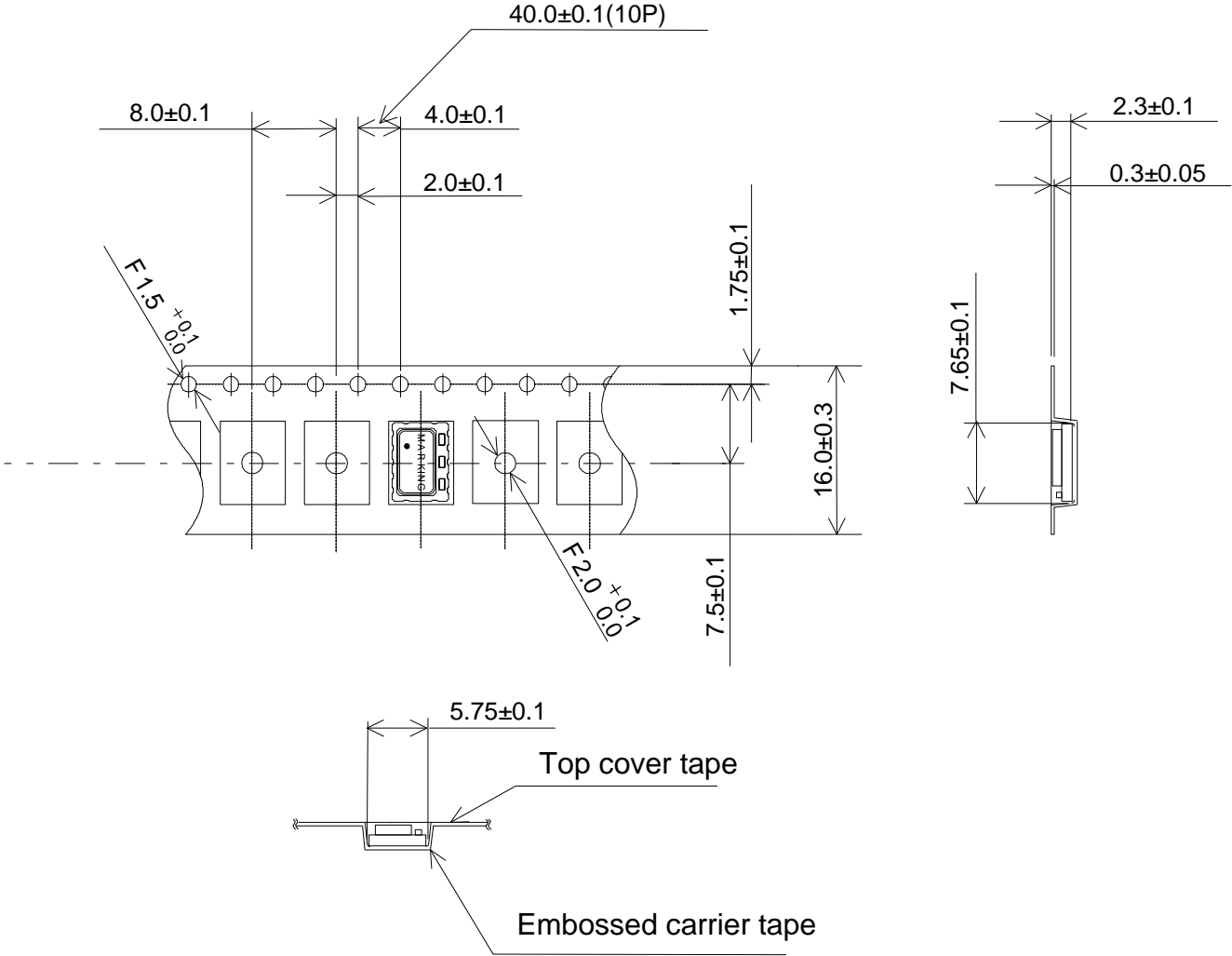

	Embossed carrier tape	Top cover tape
Materials	PS	PET+PE+Adhesive layer
Disposition	Antistatic	Antistatic

	Date of Revise	Charge	Approved	Reason
	Date	Name	Third Angle Projection	Tolerance
Drawn	18.May.2010	Y.Yokozeki	Dimension : mm	---
Designed	18.May.2010	Y.Yokozeki	Title	Drawing No.
Checked	----	-----		
Approved	18.May.2010	Y.Yokozeki		
			<b>Packing</b>	<b>ETK17B-00298(1/4)</b>
				Rev.

**NIHON DEMPA KOGYO CO., LTD.**

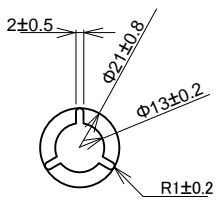
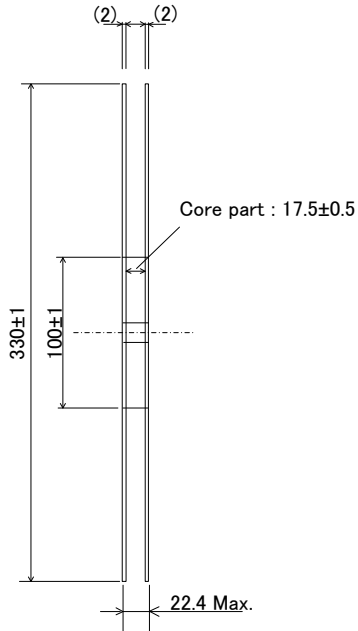
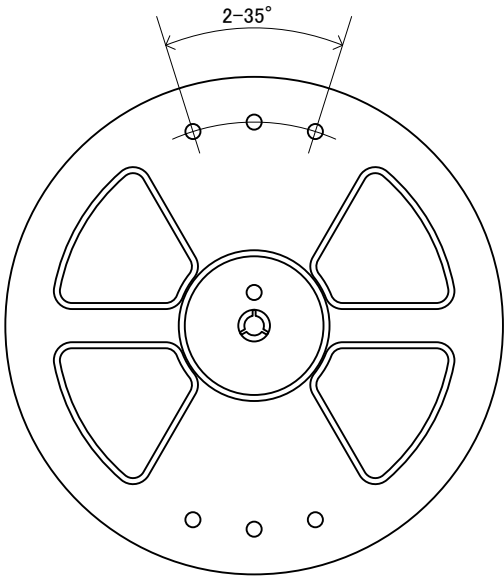

Materials : PS  
Disposition : Antistatic

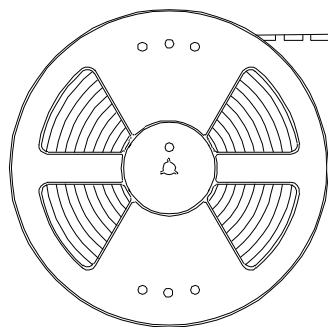
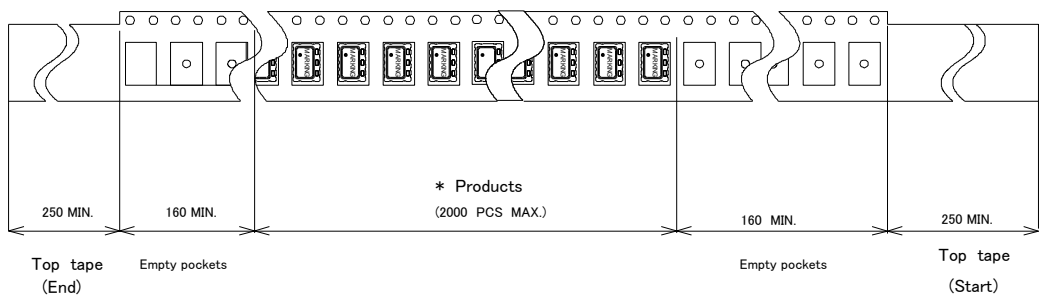

\* There are no vacant pockets for this area.

	Date of Revise	Charge	Approved	Reason
	Date	Name	Third Angle Projection	Tolerance
Drawn	18.May.2010	Y.Yokozeki	Dimension : mm	---
Designed	18.May.2010	Y.Yokozeki	Title	Drawing No.
Checked	----	----		
Approved	18.May.2010	Y.Yokozeki		
			<b>Packing</b>	<b>ETK17B-00298(2/4)</b>
				Rev.

**NIHON DEMPA KOGYO CO., LTD.**

# Tape break force, peel strength and angle

Required setting:

Tape break force: min 10N

Top cover tape strength: min 10N

Top cover tape peel force : 0.1-1.3N(0.1-1.0 for 8mm carrier tapes),at a peel speed of 300 +/-10mm/min.

Angle between the top cover tape and the direction of feed during peel off.  
165-180°

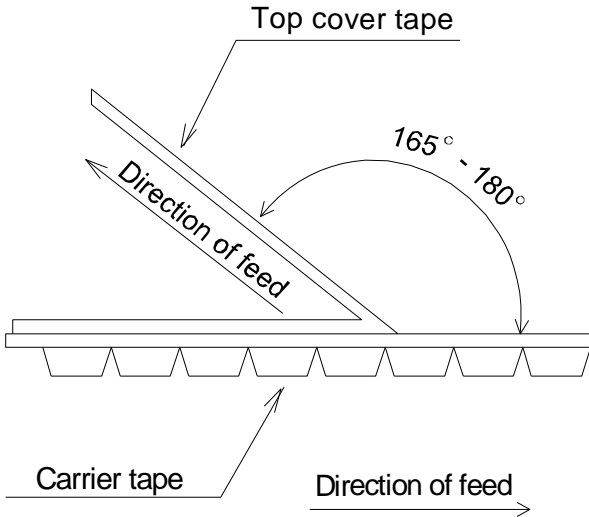

The cover tapes not extend over the edge of the carrier tape or cover any part of the sprocket holes.

	Date of Revise	Charge	Approved	Reason	
	Date	Name	Third Angle Projection	Tolerance	Scale
Drawn	18.May.2010	Y.Yokozeki	Dimension : mm	---	---
Designed	18.May.2010	Y.Yokozeki	Title <b>Packing</b>	Drawing No. <b>ETK17B-00298(3/4)</b>	Rev.
Checked	-----	-----			
Approved	18.May.2010	Y.Yokozeki			

**NIHON DEMPA KOGYO CO., LTD.**

<Inner packing>  
 Max. 1000pcs./ Reel

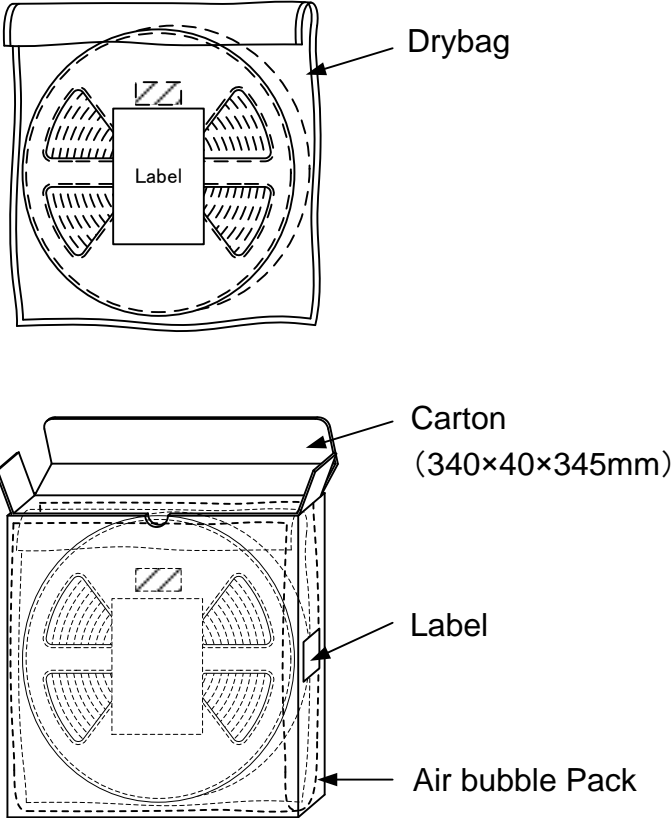

	Date of Revise	Charge	Approved	Reason	
	Date	Name	Third Angle Projection	Tolerance	Scale
Drawn	18.May.2010	Y.Yokozeki	Dimension : mm	---	---
Designed	18.May.2010	Y.Yokozeki	Title	Drawing No.	Rev.
Checked	-----	-----			
Approved	18.May.2010	Y.Yokozeki			
			<b>Packing</b>	<b>ETK17B-00298(4/4)</b>	

**NIHON DEMPA KOGYO CO., LTD.**