



RoHS Compliant
Directive 2011/65/EU

SPECIFICATION

Customer: ELTECH

Item: Quartz Crystal Controlled Oscillators

Type: NT7050BB

Nominal Frequency: 32.768 MHz

Customer's Spec. No.: ---

NDK Spec. No.: END4756A

Receipt

Charge:

Sales	NDK-I Paola Bandera	Tel. +81 02 96702920 e-Mail: bandera@it.ndk.com
Engineer	Engineering Dept.2 N.Sekine	Tel. +81 4 2900 6619 e-Mail: sekine@ndk.com

Revision Record

Rev.	Date	Items	Contents	Approved	Checked	Drawn
---	7.Jul.2014	Issue	---	T.Matsumoto	---	N.Sekine

This is specification of temperature compensated crystal oscillator.

1. Customer's Spec. No. : ---
2. NDK Spec. No. : END4756A
3. Type : NT7050BB
4. External Dimension : ETD14B-01393

5. Rating

- 5.1 Nominal Frequency (f_{nom})
32.768 MHz
- 5.2 Supply Voltage (V_{CC})
DC+3.3 V \pm 5 %
- 5.3 Control Voltage (V_{cont})
DC+1.65 V \pm 1.0 V
- 5.4 Output Load Condition (C_L)
15 pF \pm 10 %
- 5.5 Operating Temperature Range (T_{opr})
-40 °C to +85 °C
- 5.6 Storage Temperature Range (T_{str})
-55 °C to +125 °C

6. Electrical Specification

Unless otherwise specified, measuring condition $T = +25\pm 2$ °C, $V_{CC} = +3.3$ V, $V_{cont} = +1.65$ V, $C_L = 15$ pF.

	Item	Symbol	Condition	Spec. Value		Unit
				Min.	Max.	
6.1	Current Consumption	I_{CC}	-	-	6	mA
6.2	Overall Frequency Tolerance					
	6.2.1 Frequency Tolerance	$\Delta f/f_{nom}$	At the shipment (*1)	-1.0	+1.0	ppm
	6.2.2 Frequency/Temperature Characteristics	$\Delta f/f$	-40 °C to +85 °C (*2)	-0.5	+0.5	ppm
	6.2.3 Frequency/Voltage Coefficient	$\Delta f/f$	DC+3.3 V \pm 5 % (*2)	-0.1	+0.1	ppm
	6.2.4 Frequency/Load Coefficient	$\Delta f/f$	15 pF \pm 10 % (*2)	-0.1	+0.1	ppm
	6.2.5 Long-Term Frequency Stability	$\Delta f/f$	1 year	-1.0	+1.0	ppm
6.3	Output		CMOS			
	6.3.1 Output Voltage (Square)	V_{OH}	-	90 % V_{CC}	-	V
		V_{OL}	-	-	10 % V_{CC}	V
	6.3.2 Symmetry	SYM	50 % V_{out}	45	55	%
	6.3.3 Rise Time	t_r	10 % to 90 % V_{out}	-	8	ns
	6.3.4 Fall Time	t_f	90 % to 10 % V_{out}	-	8	ns

	Item	Symbol	Condition	Spec. Value		Unit
				Min.	Max.	
6.4	Frequency Controlled Characteristics					
6.4.1	Frequency Control Range	$\Delta f/f$	$V_{\text{cont}}=+0.65 \text{ V}$ (*2)	-	-5	ppm
			$V_{\text{cont}}=+2.65 \text{ V}$ (*2)	+5	-	ppm
6.4.2	Input Impedance	Z_{in}	-	100	-	k Ω
6.4.3	Frequency Change Polarity	-	-	Positive		-

(*1) $\Delta f/f_{\text{nom}}$: Frequency shift at $T = +25 \pm 2 \text{ }^\circ\text{C}$, $V_{\text{CC}} = +3.3 \text{ V}$, $V_{\text{cont}} = +1.65 \text{ V}$, $C_L = 15 \text{ pF}$ in reference to nominal frequency (f_{nom}).

(*2) $\Delta f/f$: Frequency shift from the reference frequency at $T = +25 \pm 2 \text{ }^\circ\text{C}$, $V_{\text{CC}} = +3.3 \text{ V}$, $V_{\text{cont}} = +1.65 \text{ V}$, $C_L = 15 \text{ pF}$.

7. Test circuit

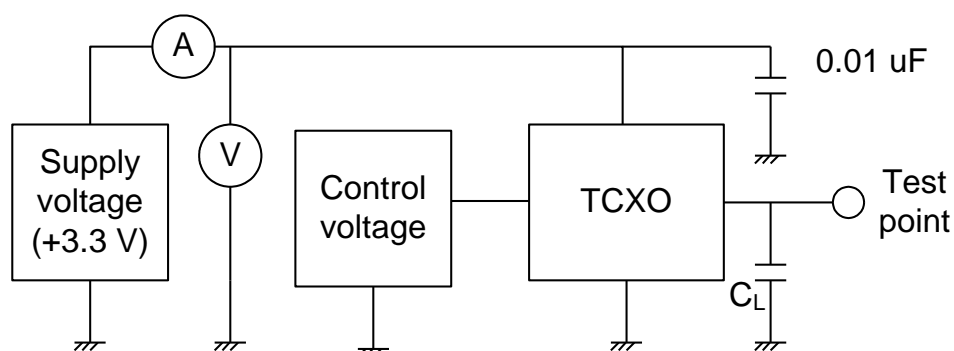

C_L : Including capacitance probe and jig.

Fig.1 Test Circuit

8. Environmental Conditions

	Item	Condition	Specification
8.1	Vibration Test	IEC60068-2-6, test Fc 10 to 500 Hz, 98.1 m/s^2 , 2 hours, 3 direction.	After following test, Complies with all items of electrical characteristic specification.
8.2	Shock Test	IEC60068-2-27, test Ea 981 m/s^2 , 6 ms, Half Sine, 3 bumps, 6 directions.	

9. Marking

Type
Nominal Frequency (MHz is not written)
NDK Symbol Mark
Lot No.
Dot Mark

10. Moisture Sensitivity Level

Level 3 (Compliant with J-STD-020)

11. Packing

ETK17B-00338

12. Notice

- 12.1 Order items are manufactured according to specification. As to conditions, which are not indicated in this specification and unpredictable such as applied condition and oscillation margin, please check them beforehand.
- 12.2 Unless we receive request for modification within 3 weeks from the issue date of this NDK specification sheet, we will supply products according to this specification. Also, if you'd like to modify specification of order, which has been placed with delivery request within 3 weeks from the issue data of this specification sheet, we would like to discuss with you separately.
- 12.3 In no event shall the company be liable for any product failure resulting from an inappropriate handling or operation of the product beyond the scope of its guarantee.
- 12.4 Where any change to the process condition is made due to the change(s) in the production line, inform personnel of the specifications.
- 12.5 Should this specification data give rise to any disputes relating to any intellectual property rights or any other rights of a third person, the company shall not indemnify anyone for any damage. Their disclosure must not be construed as the grant of a license to use any of the intellectual property rights owned by the company.
- 12.6 If you intend to use products listed on this specification for applications that may result in loss of life or assets (controls relating to safety, medical equipment, aeronautical equipment, space equipment, etc.), please do not fail to advise us of your intention beforehand.
- 12.7 In the company's production process whatever amount of ozone depleting substances (ODS) as specified in the Montreal protocol is not used.
- 12.8 Information contained in this specification must not be quoted, reproduced or used for other purposes including processing either in part or in full without obtaining prior approval from the company.

13. Prohibited items

Be sure to use the product under the following conditions. Otherwise, the characteristics deterioration or destruction of the product may result.

- (1) Reflow soldering heat resistance
 - Preheating: 150 °C to 200 °C, 60 s to 120 s
 - Ramp up rate: Max. 3 °C/s
 - Heating: 217 °C or higher, 30 s to 90 s
 - Peak temperature: 245 °C, +0/-5 °C
 - Time within 5 °C of Peak temperature: < 30 s
 - Reflow passage times: twice
 - In reflowing, the turning over of mounted boards shall be forbidden.
- (2) Manual soldering heat resistance
 - Press a soldering iron of 350°C on the lead electrode for five seconds (twice).
- (3) Washing
 - This product does not correspond to rinsing.

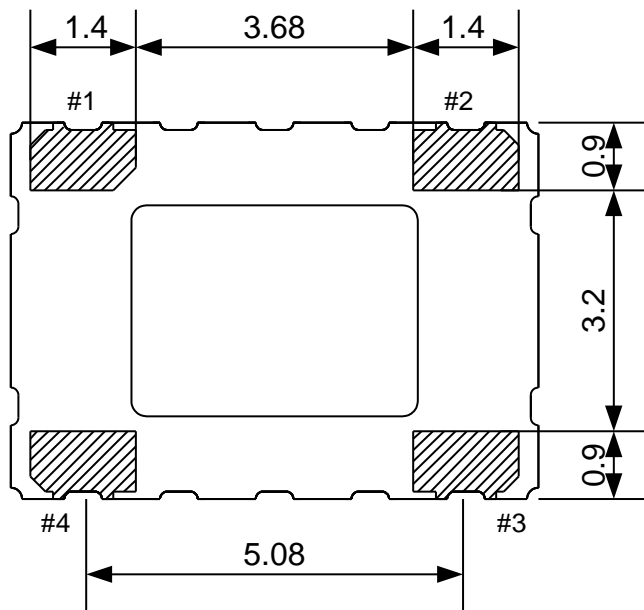
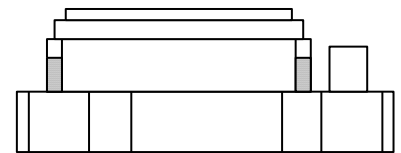
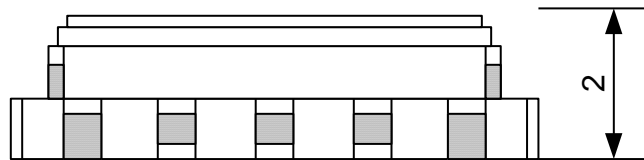
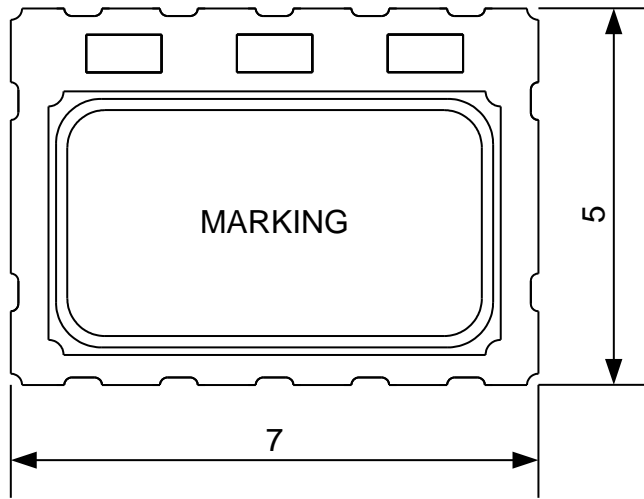

Terminal land Connections

#1	V _{cont}
#2	GND
#3	OUTPUT
#4	V _{CC}

	Date of Revise	Charge	Approved	Reason	
B	26.Feb.2014	N.Sekine	T.Matsumoto	Central hatching in undersurface drawing was deleted. [Change] #1:VCONT→V _{cont} , *1 and #4:VCC→V _{CC}	
	Date	Name	Third Angle Projection	Tolerance	Scale
Drawn	18.May.2010	Y.Yokozeki	Dimension:mm	±0.2	10/1
Designed	18.May.2010	Y.Yokozeki	Title	Drawing No.	Rev.
Checked	-----	-----			
Approved	18.May.2010	Y.Yokozeki			
			External Dimension	ETD14B-01393	B

NIHON DEMPA KOGYO CO., LTD.

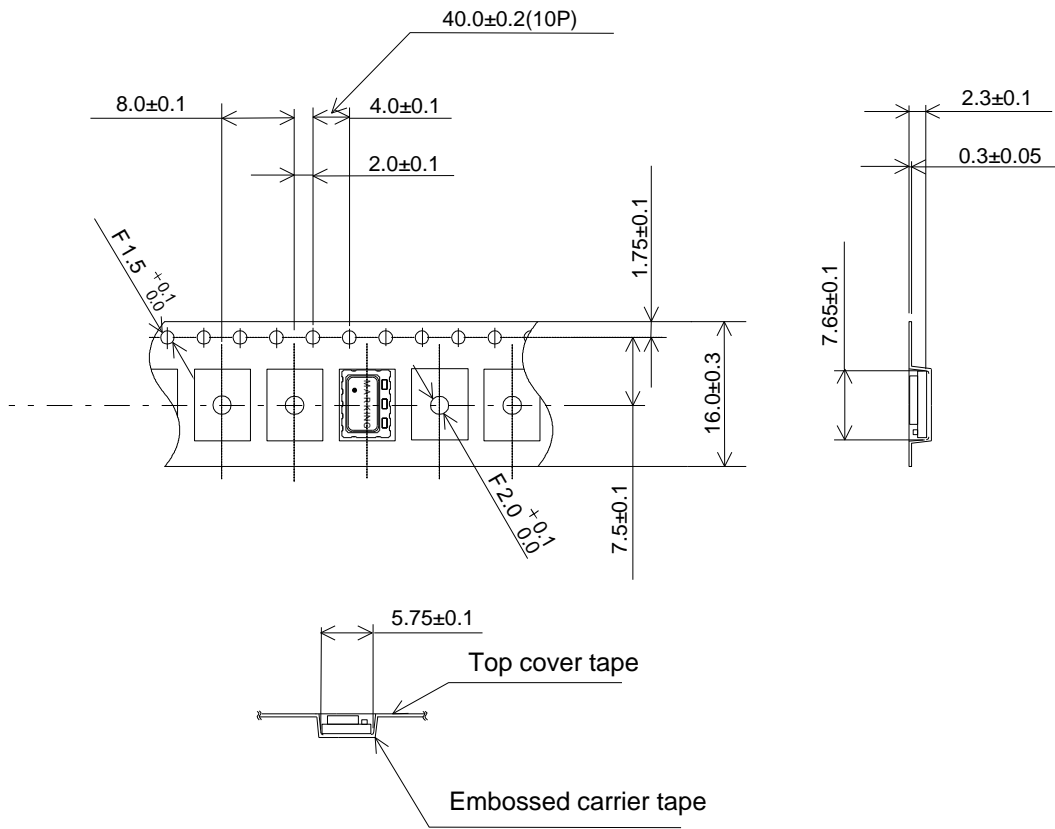

	Embossed carrier tape	Top cover tape
Materials	PS	PET+PE+Adhesive layer
Disposition	Antistatic	Antistatic

Date of Revise		Charge	Approved	Reason	
	Date	Name	Third Angle Projection	Tolerance	Scale
Drawn	07.Jan.2011	T.Terashima	Dimension : mm	---	---
Designed	07.Jan.2011	T.Terashima	Title	Drawing No.	Rev.
Checked	----	-----			
Approved	07.Jan.2011	Y.Yokozeki			
			Packing(1/4)	ETK17B-00338	

NIHON DEMPA KOGYO CO., LTD.

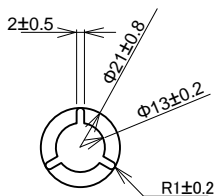
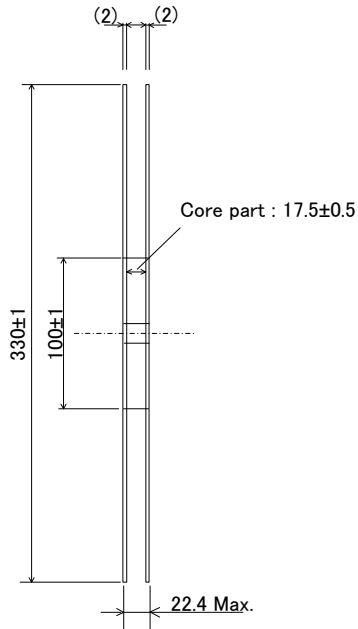
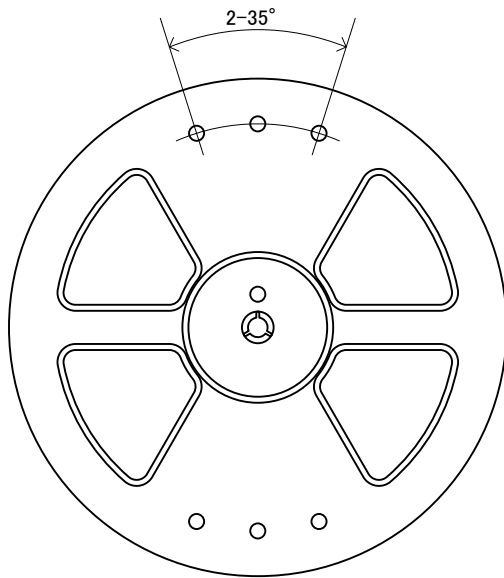

Materials : PS
Disposition : Antistatic

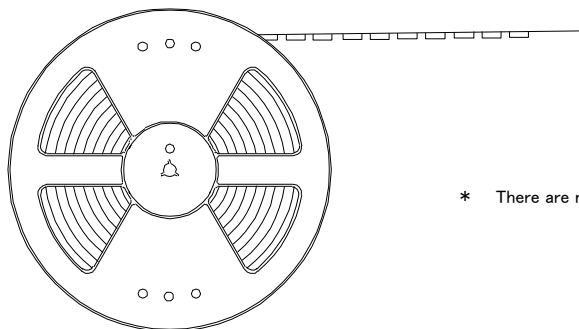
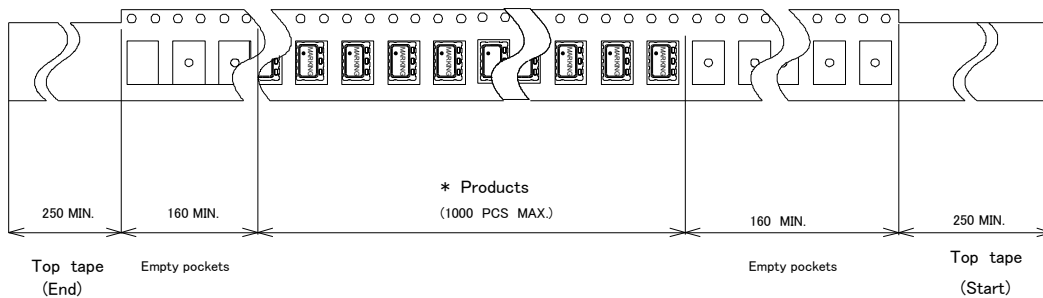

* There are no vacant pockets for this area.

Date of Revise		Charge	Approved	Reason	
Drawn	07.Jan.2011	T.Terashima	Third Angle Projection		Scale
Designed	07.Jan.2011	T.Terashima	Dimension : mm		---
Checked	----	----	Title		Drawing No.
Approved	07.Jan.2011	Y.Yokozeki			
Packing(2/4)			ETK17B-00338		Rev.

NIHON DEMPA KOGYO CO., LTD.

Tape break force, peel strength and angle

Required setting:

Tape break force: min 10N

Top cover tape strength: min 10N

Top cover tape peel force : 0.1-1.3N(0.1-1.0 for 8mm carrier tapes),at a peel speed of 300 +/-10mm/min.

Angle between the top cover tape and the direction of feed during peel off.
165-180°

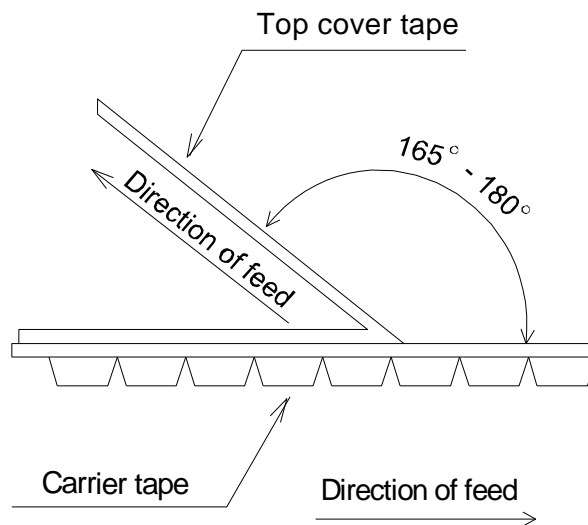

The cover tapes not extend over the edge of the carrier tape or cover any part of the sprocket holes.

Date of Revise		Charge	Approved	Reason	
	Date	Name	Third Angle Projection	Tolerance	Scale
Drawn	07.Jan.2011	T.Terashima	Dimension : mm	---	---
Designed	07.Jan.2011	T.Terashima	Title	Drawing No.	Rev.
Checked	----	-----			
Approved	07.Jan.2011	Y.Yokozeki			
			Packing(3/4)	ETK17B-00338	

NIHON DEMPA KOGYO CO., LTD.

<Inner packing>
 Max. 1000pcs./ Reel

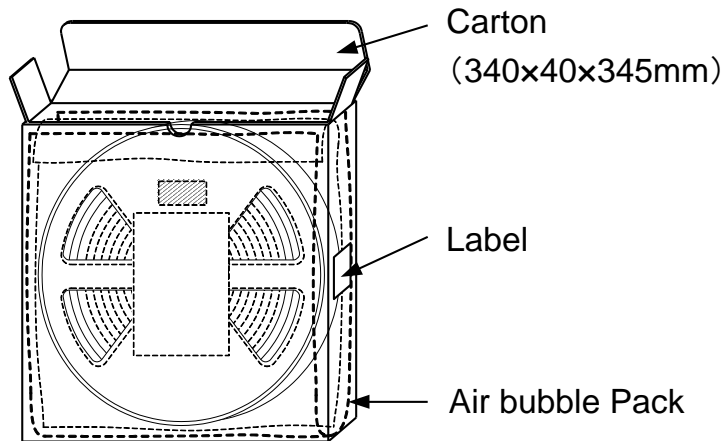
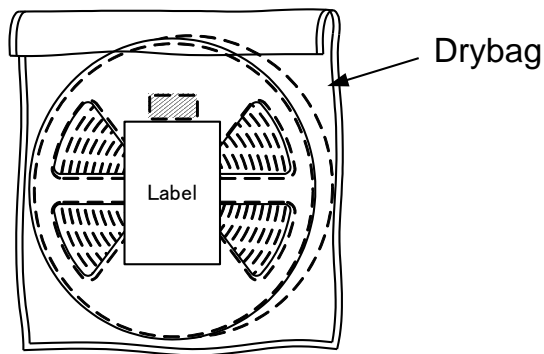

	Date of Revise	Charge	Approved	Reason	
	Date	Name	Third Angle Projection	Tolerance	Scale
Drawn	07.Jan.2011	T.Terashima	Dimension : mm	---	---
Designed	07.Jan.2011	T.Terashima	Title	Drawing No.	Rev.
Checked	----	-----			
Approved	07.Jan.2011	Y.Yokozeki			
			Packing(4/4)	ETK17B-00338	

NIHON DEMPA KOGYO CO., LTD.