

Temperature Compensated Crystal Oscillator

■ NT5032BB Data Sheet

High-Precision TCXO

Applications

- STRATUM3 compatible devices
- Base Station
- Backbone Network Equipment

Features

- Output specifications: CMOS, Clipped Sine
- Low current consumption: Max.8.0 mA
- Dimensions : 5.0 × 3.2 mm, Height : 1.8 mm
Uses a small package



RoHS Compliant
Directive 2011/65/EU
Directive (EU) 2015/863

Pb
free
Halogen
free

1. Item : Temperature Compensated Crystal Oscillator (TCXO)

2. Type : NT5032BB

3. Nominal Frequency : 10.000 to 40.000 MHz

4. NDK Spec. No.

NDK Spec. No.	NSC5119Q (CMOS)	NSC5119P (Clipped Sine)
Frequency Range [MHz]	10 ≤ f ≤ 40	

5. Maximum Rating

	Item	Rating	Units
1	Supply Voltage	-0.6 to +4.6	V
2	Input Voltage Range	-0.6 to V _{CC} +0.6, Max.+4.6	V
3	Storage Temperature Range	-40 to +105	°C

6. Rating

6-1 CMOS

	Item	Rating				Notes
		Min.	Typ.	Max.	Units	
1	Nominal Frequency	10.000		40.000	MHz	Refer to Table1- (-Earth)
2	Supply Voltage (V _{CC})	+3.135	+3.3	+3.465	V	
3	Control Voltage (V _{cont})	0	+1.65	+3.3	V	
4	Operating Temp. Range	-40		+85	°C	
5	Load capacitance	13.5	15	16.5	pF	

6-2 Clipped Sine

	Item	Rating				Notes
		Min.	Typ.	Max.	Units	
1	Nominal Frequency	10.000		40.000	MHz	Refer to Table1- (-Earth)
2	Supply Voltage (V _{CC})	+3.135	+3.3	+3.465	V	
3	Control Voltage (V _{cont})	0	+1.65	+3.3	V	
4	Operating Temp. Range	-40		+85	°C	
5	Load resistance	9	10	11	kΩ	
6	Load capacitance	9	10	11	pF	

Table 1 Main Frequency List

NDK Spec. No.	Nominal Frequency [MHz]				
NSC5119Q (CMOS)	10.000	12.800	19.200	19.440	20.000
NSC5119P (Clipped Sine)	24.576	25.000	25.600	26.000	-

* Please contact us for frequencies not listed.

7. Electrical Specification

7-1 CMOS

Unless otherwise specified, measuring condition : $T = +25 \pm 2 \text{ }^\circ\text{C}$, $V_{CC} = +3.3 \text{ V}$, $V_{cont} = +1.65 \text{ V}$, $C_L = 15 \text{ p}$

	Parameters	Electrical Spec.				Notes	
		Min.	Typ.	Max.	Units		
1	Current Consumption			8.0	mA		
2	Frequency Stability						
	1. Overall Frequency Tolerance (*1)	-4.6		+4.6	ppm	Total of Para. 7-1.2.2 to 7-1.2.6 (15 years)	
	2. Frequency / Temperature Characteristics	-0.28		+0.28	ppm	-40 to +85 $^\circ\text{C}$ Frequency shift from the reference frequency at $(F_{max} + F_{min})/2$. at control voltage (V_{cont}) = +1.65 V	
	3. Frequency / Voltage Coefficient	-0.1		+0.1	ppm	+3.3 V $\pm 5 \%$	
	4. Frequency / Load Coefficient	-0.2		+0.2	ppm	15 pF $\pm 10 \%$	
	5. Frequency Tolerance	-0.7		+0.7	ppm	At shipping, based on nominal frequency at control voltage (V_{cont}) = +1.65 V	
6. Long-term Frequency Stability		-1.0		+1.0	ppm	Year	
		-3.0		+3.0	ppm	15 years at +25 $\pm 2 \text{ }^\circ\text{C}$	
3	Output	CMOS					
	1. Output Voltage (Square)			10 % V_{CC}	V	V_{OL}	
		90 % V_{CC}			V	V_{OH}	
	2. Symmetry	45		55	%	50 % V_{CC}	
	3. Rise Time (t_r)			8	ns	10 % to 90 % V_{CC}	
4. Fall Time (t_f)			8	ns	90 % to 10 % V_{CC}		
4	Frequency Controlled Characteristics						
	1. Frequency Control Range			-5.0	ppm	$V_{cont} = 0 \text{ V}$	based on frequency at (V_{cont}) = +1.65 V
		+5.0			ppm	$V_{cont} = +3.3 \text{ V}$	
2. Frequency Change Polarity	Positive						

*1 Total of Frequency / Temperature Characteristics, Frequency Tolerance, Frequency / Voltage Coefficient, Frequency / Load Coefficient, Long-term Frequency Stability (15 years)

7-2 Clipped Sine

Unless otherwise specified, measuring condition: T = +25 ±2 °C, V_{CC} = +3.3 V, V_{cont} = +1.65 V, Load = 10 kΩ // 10 pF

	Parameters	Electrical Spec.				Notes	
		Min.	Typ.	Max.	Units		
1	Current Consumption			8.0	mA		
2	Output voltage	0.8			V _{p-p}	Clipped sine wave (DC-Coupling)	
3	DC-cut capacitor					DC-cut capacitor of output is not put in TCXO. Please add DC-cut capacitor (1000 pF) in output line.	
Frequency Stability							
4	1. Overall Frequency Tolerance (*1)	-4.6		+4.6	ppm	Total of Para. 7-2.4.2 to 7-2.4.6 (15 years) -40 to +85 °C	
	2. Frequency / Temperature Characteristics	-0.28		+0.28	ppm	Frequency shift from the reference frequency at (Fmax + Fmin) / 2. at control voltage (V _{cont}) = +1.65 V	
	3. Frequency / Voltage Coefficient	-0.1		+0.1	ppm	+3.3 V ±5 %	
	4. Frequency / Load Coefficient	-0.2		+0.2	ppm	(10 kΩ // 10 pF) ±10 %	
	5. Frequency Tolerance	-0.7		+0.7	ppm	At shipping, based on nominal frequency at control voltage (V _{cont}) = +1.65 V	
	6. Long-term Frequency Stability	-1.0 -3.0		+1.0 +3.0	ppm ppm	Year 15 years at +25 ±2 °C	
Frequency Controlled Characteristics							
5	1. Frequency Control Range			-5.0	ppm	V _{cont} = 0 V	based on frequency at (V _{cont}) = +1.65 V
		+5.0			ppm	V _{cont} = +3.3 V	
	2. Frequency Change Polarity	Positive					

*1 Total of Frequency / Temperature Characteristics, Frequency Tolerance, Frequency / Voltage Coefficient, Frequency / Load Coefficient, Long-term Frequency Stability (15 years)

Output Waveform
Output : CMOS

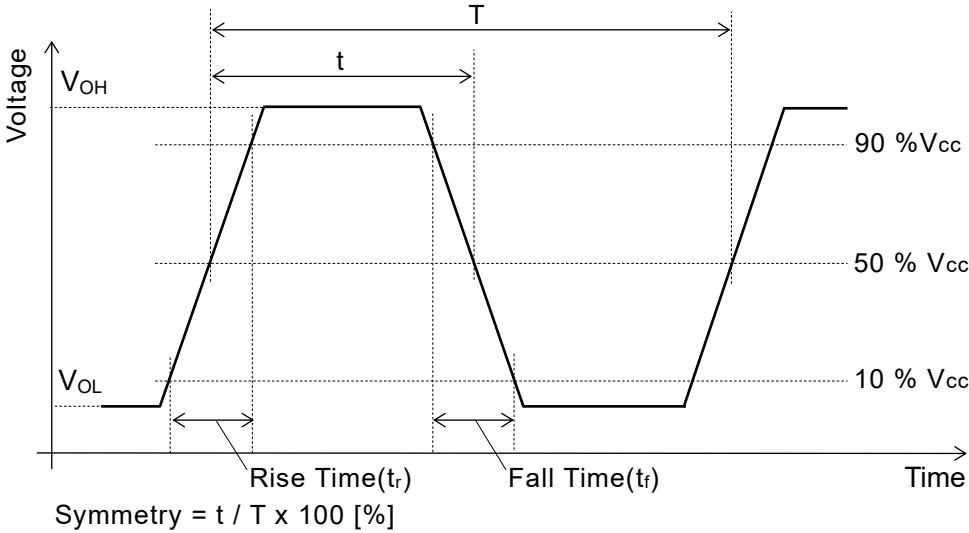

Output : Clipped Sine

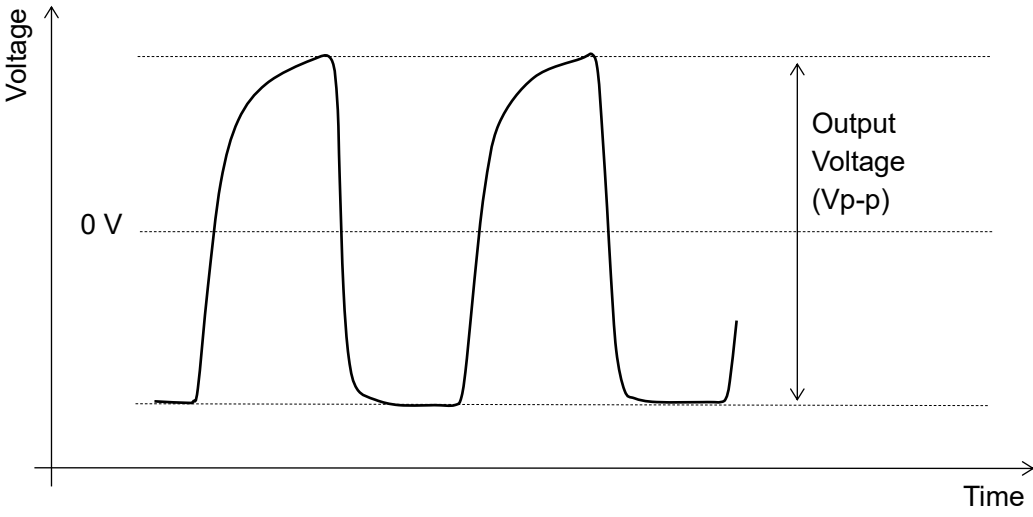

Measurement Circuit
Output : CMOS

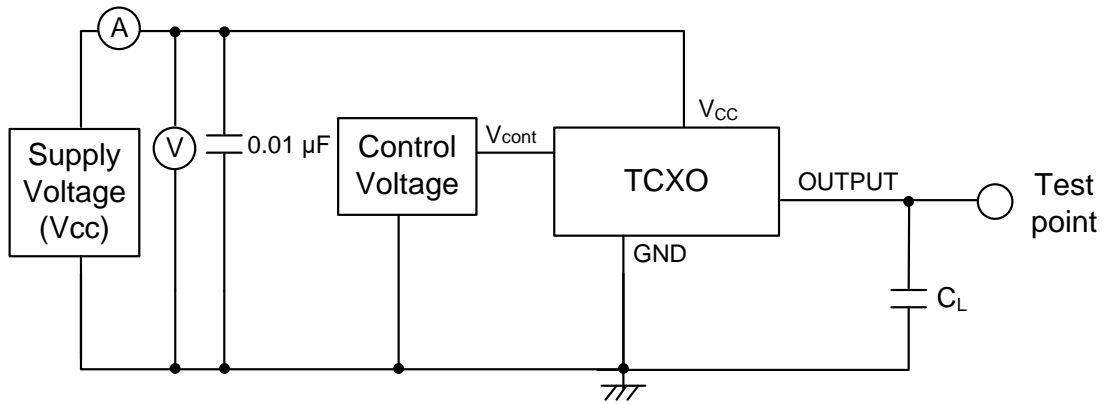

C_L including capacitance of probe and jig

Output : Clipped Sine

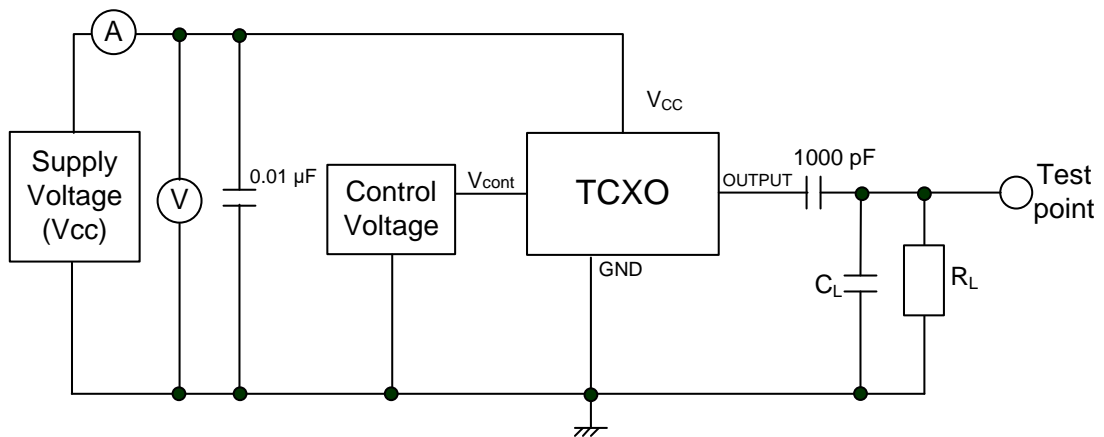

C_L, R_L including impedance and capacitance of probe and jig.

■ How to contact us

When making an inquiry or placing an order for this product, please let us know the specifications using the following method.

If you require other specifications, please contact us separately.

NT5032BB - 20.000 A F J R M

Main Frequency [MHz]	
10.000	24.576
12.800	25.000
19.200	25.600
19.440	26.000
20.000	-

※ Please contact us for frequencies not listed.

Supply Voltage	
+3.3 V	A

Input Voltage Range	
+1.65 V	F
None	N

Output	
CMOS	J
Clipped sine	K

Frequency/Temp. Characteristics	
$\pm 0.28 \times 10^{-6}$	R

Operating Temp. Range	
-40 to +85 °C	M

8. Mounted Conditions

Reflow solder mounting is recommended. The temperature profile is as follows.

Be sure to use the product under the following conditions. Otherwise, the characteristics deterioration or destruction of the product may result.

(1) Reflow soldering heat resistance

Peak temperature: 260 °C /10 s

Heating: +225 °C or higher, 30 s

Preheat: 150 °C to 180 °C /120 s

Number of reflow passes: 2 times

(2) Iron heat resistance

Apply iron of 350 °C on the product for 5 s. (2 times)

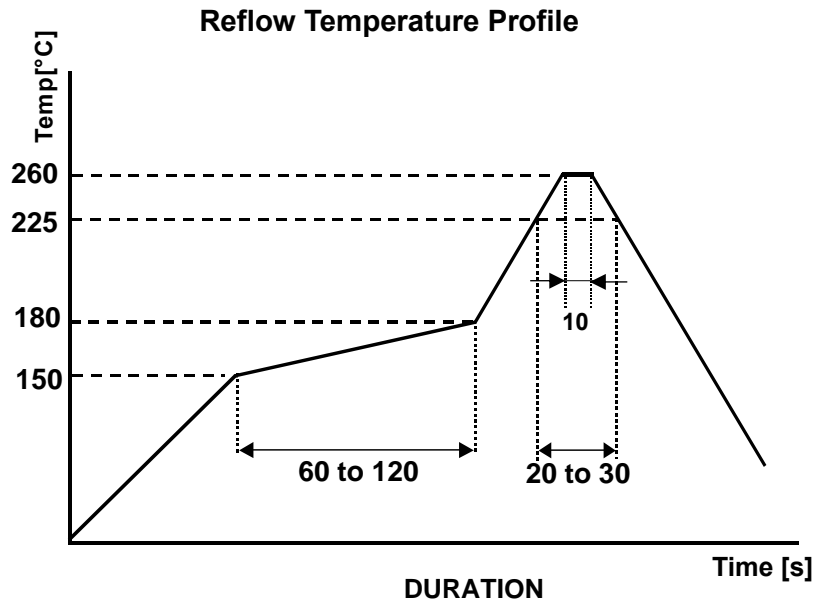

9. Precaution in the storage

When storing the product in high temperature and high humidity condition for a long time, product characteristics (solder ability etc.) and packaging condition may be deteriorated.

The product storage deadline is 6 months after delivery in unopened state. Please use within 6 months.

If you exceed 6 months please check the product characteristics etc, please use.

Please store under the conditions shown in Table 2 below.

Table 2 Storage Condition

MSL		Before taking out of dry bag	After taking out of dry bag
3	Temperature	+5 °C to +45 °C	Max. +30 °C
	Humidity	10 % to 75 %	Max. 60 %
	Period	6 months	168 hours

10. Electrostatic withstand voltage specification

•Machine Model / MM

Max. ±200 V (JEDEC EIA: JESD22-A115)

•Human Body Model / HBM

Max. ±2000 V (JEDEC EIA: JESD22-A114)

•Charged Device Model / CDM

Max. ±500 V (JEDEC EIA: JESD22-C101)

External Dimensions

Output : CMOS

Units: mm

Tolerance : ± 0.2

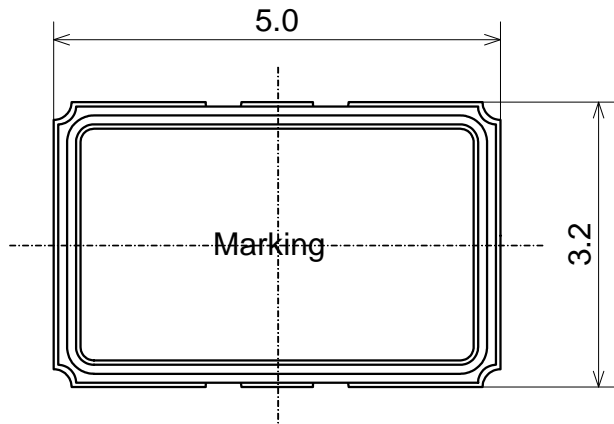

Terminal Land Connections

#1	V _{cont} or DNC
#2	GND
#3	OUTPUT
#4	V _{cc}

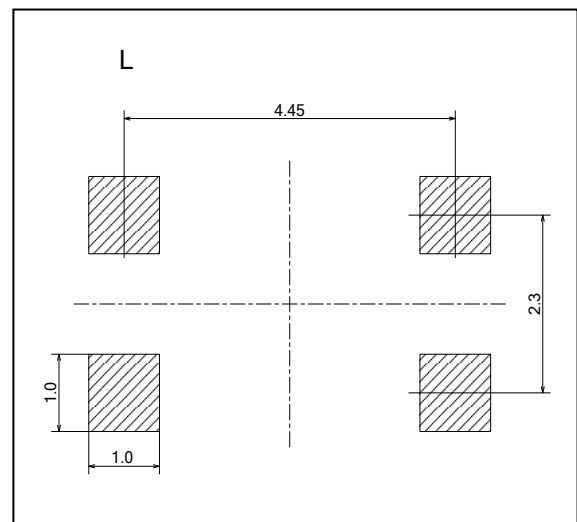
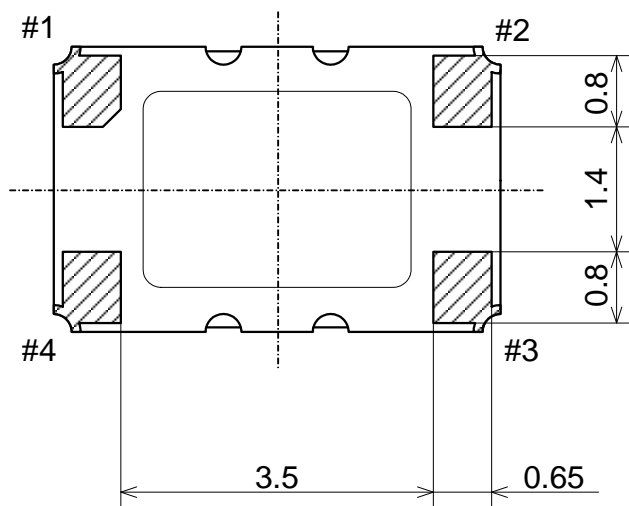
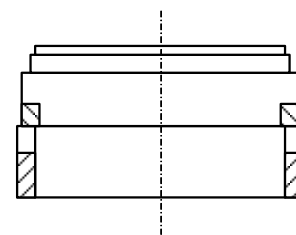
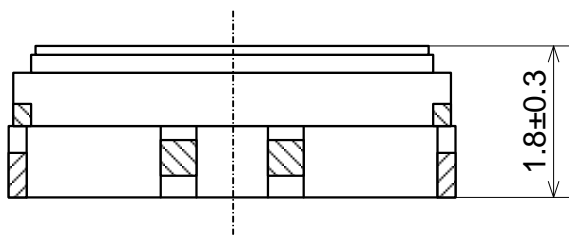

(Note)

1. Please connect the bypass capacitor (for example: 0.01 μ F) near the V_{cc} terminal.

Output : Clipped Sine

Units: mm

Tolerance : ± 0.2

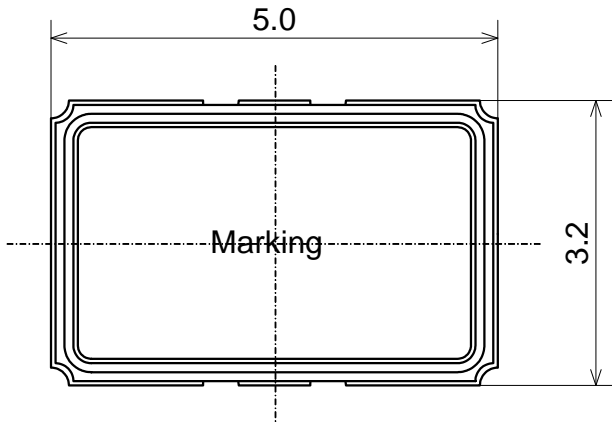

Terminal Land Connections

#1	V _{cont} or DNC
#2	GND
#3	OUTPUT
#4	V _{cc}

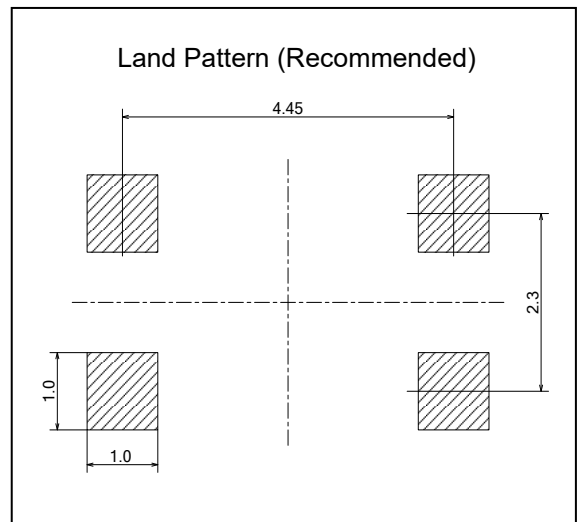
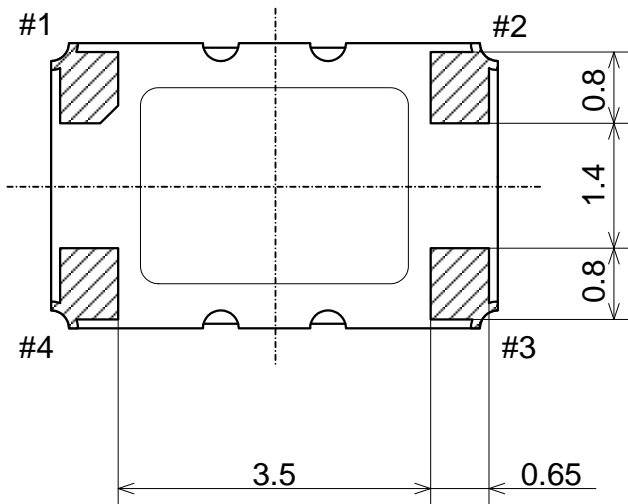
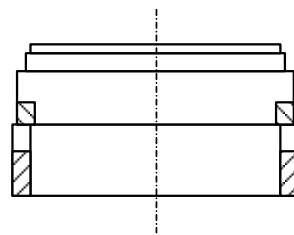
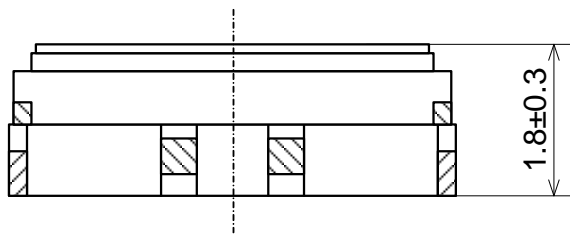

(Note)

1. Please connect the bypass capacitor (for example: 0.01 μ F) near the V_{cc} terminal.
2. The capacitor (1000 pF) for DC cut is connected with OUTPUT terminal in series.

■ Taping & Reel Specifications

Units: mm

Storage quantity : 500 pcs Max.

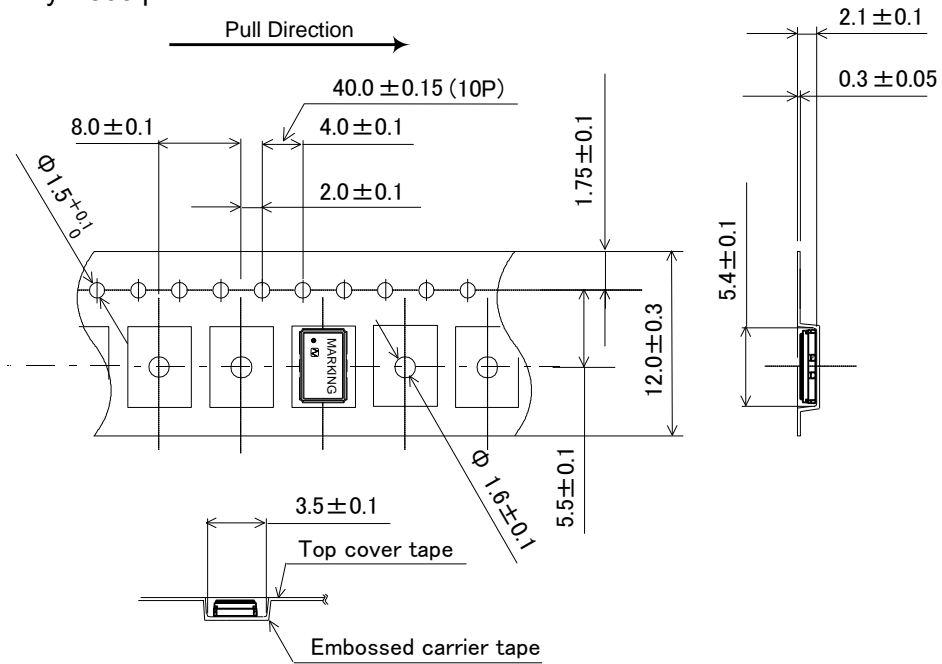

	Embossed carrier tape	Top cover tape
Materials	PS	PET+PE+Adhesive layer
	Antistatic	Antistatic

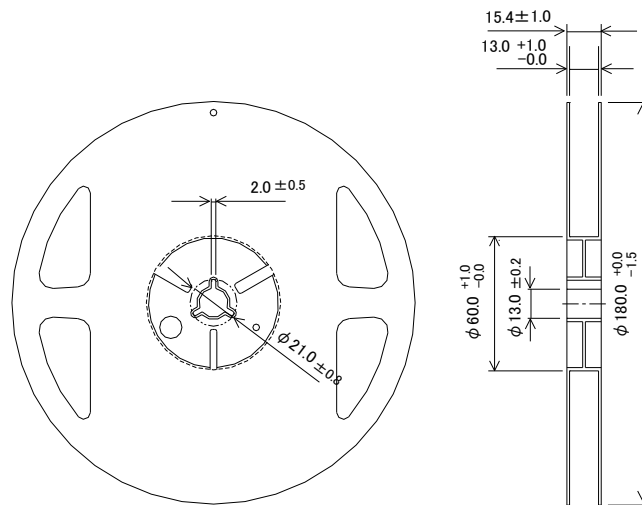

Materials : PS+Carbon
Disposition : Conductive

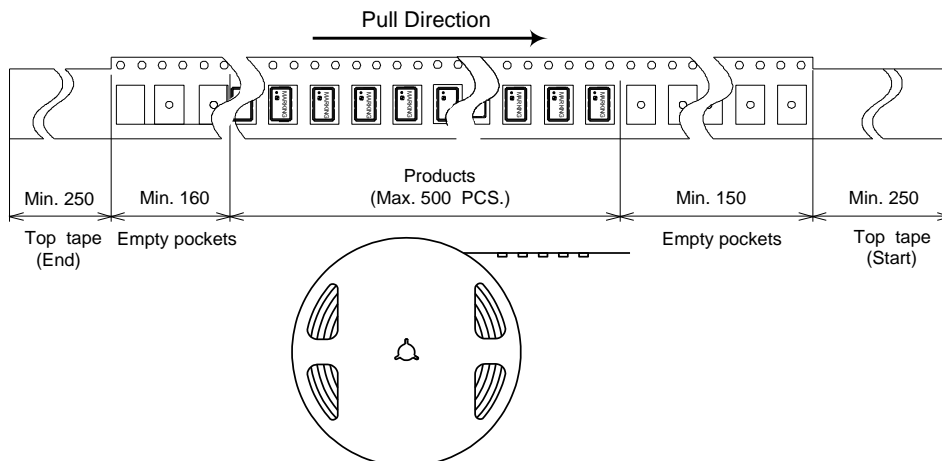

■ Marking Specifications

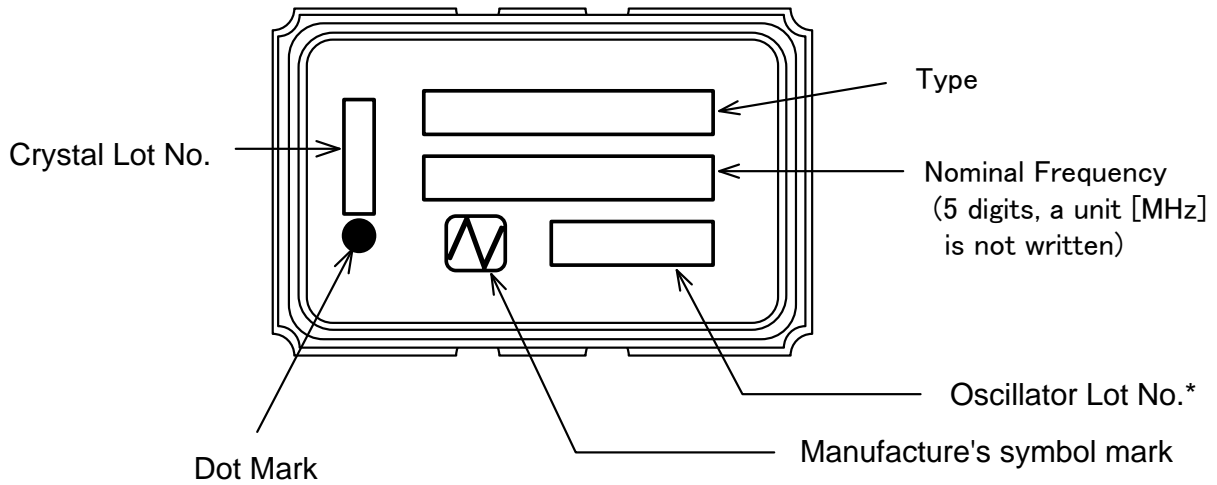

【Reference】

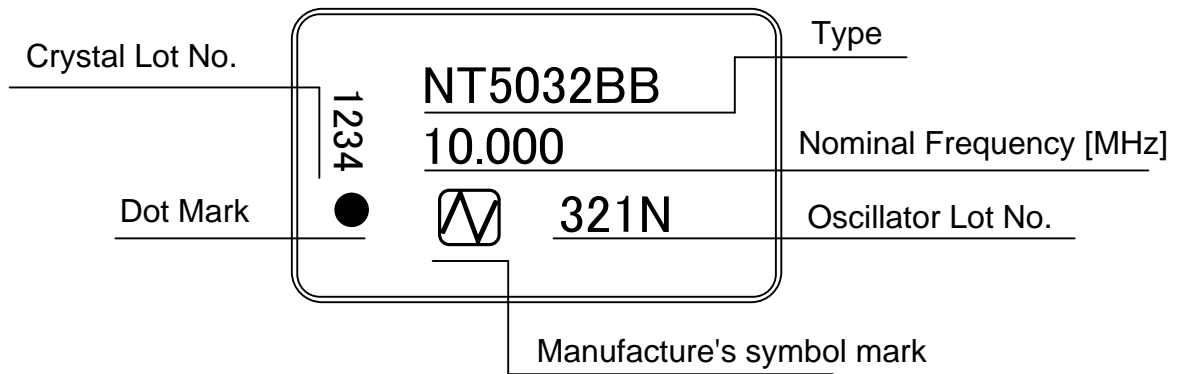

■ Reference Data 【Frequency: 20.000 MHz】

Frequency Temperature Characteristics

Output : CMOS

Specification : Max. ± 0.28 ppm / -40 to +85 °C

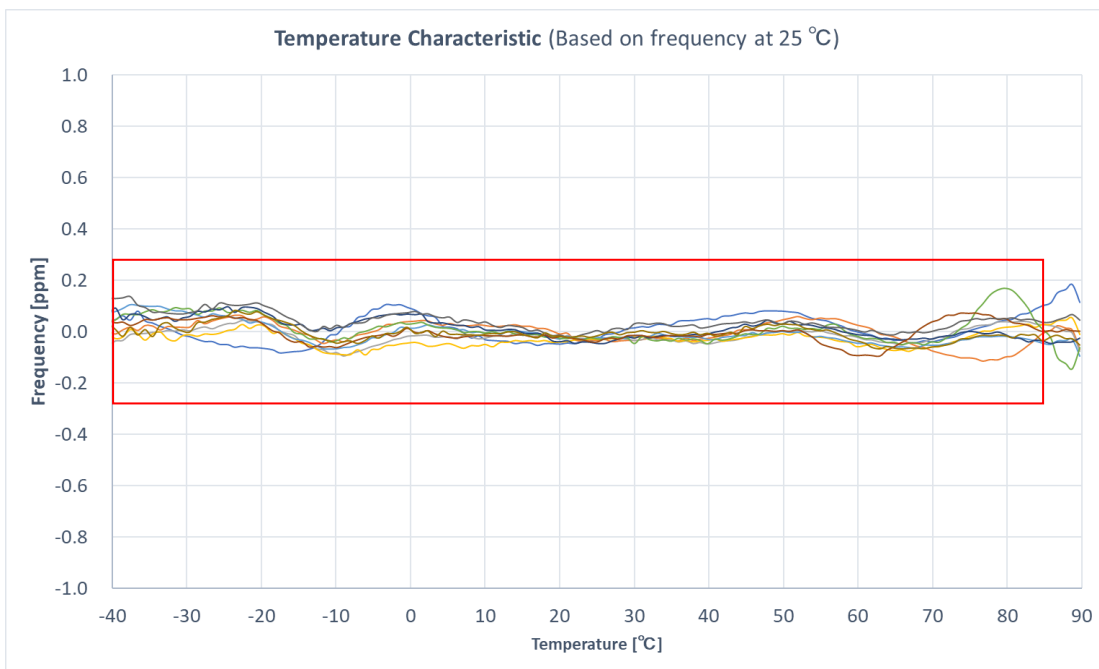

Output : Clipped Sine

Specification : Max. ± 0.28 ppm / -40 to +85 °C

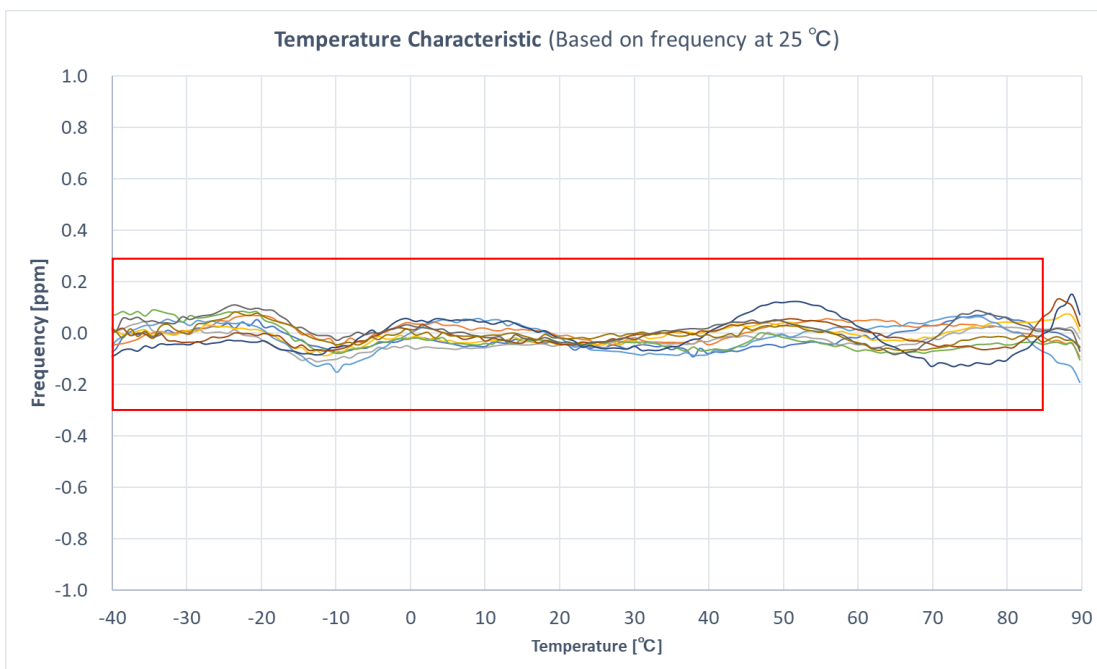

Phase Noise

Output : CMOS

Temp = +25 ±2 °C, V_{CC} = 3.3 V

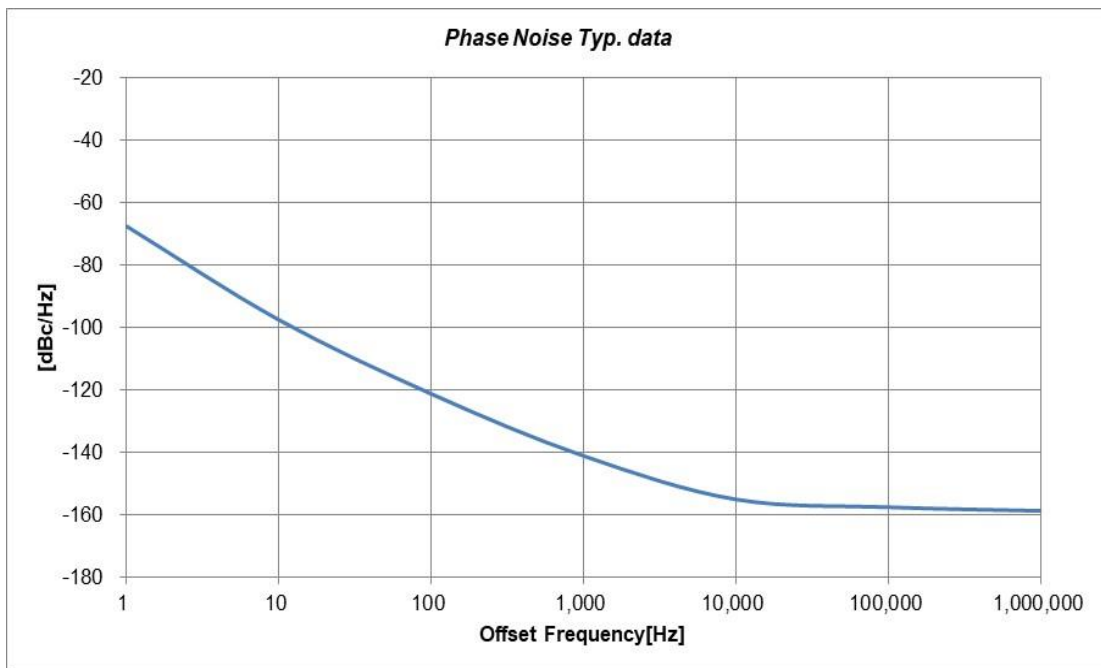

Output : Clipped Sine

Temp = +25 ±2 °C, V_{CC} = 3.3 V

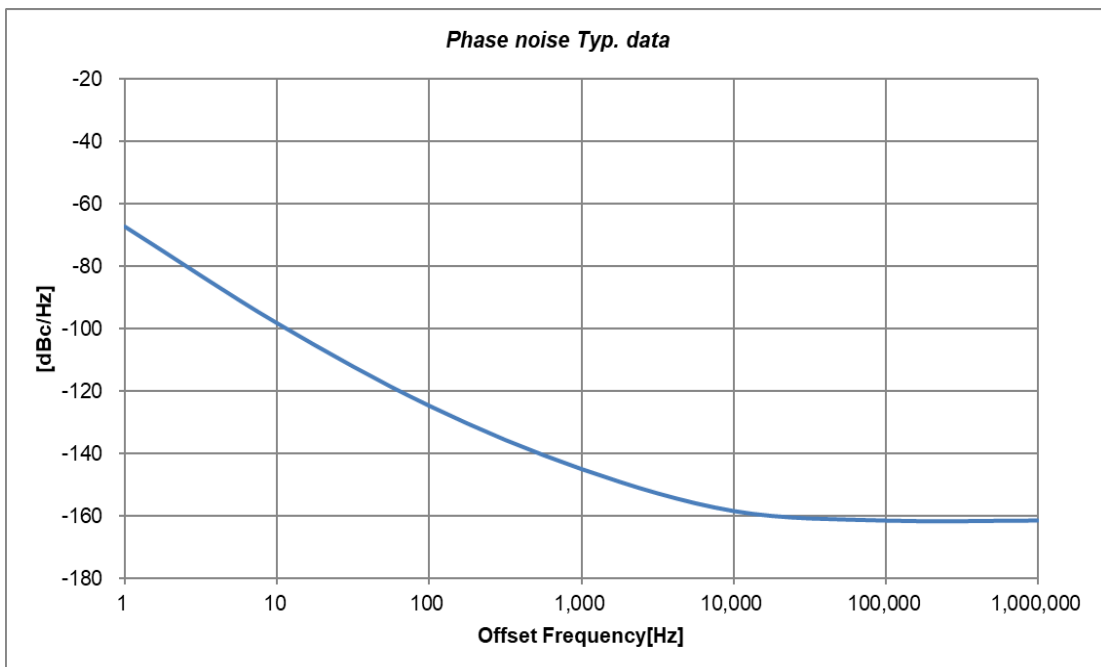

Handling Precautions

1. Washing
Not available for washing.
2. DC-cut capacitor ※Clipped Sine only
DC-cut capacitor of output is not put in TCXO. Please add DC-cut capacitor (1000 pF) in output line.

Notes On Use

1. This product cannot be used for automotive applications.
2. Even if the appearance color etc. of the product differs by purchasing the component parts by more than two companies, there is no influence on the characteristics and reliability.
3. IN THE CASE OF THE FOLLOWING ITEMS, WE ARE NOT RESPONSIBLE FOR WARRANTY / COMPENSATION.
 - (1) WHEN PRODUCTS OF THIS SPECIFICATION ARE USED FOR EQUIPMENT RELATED TO HUMAN LIFE OR PROPERTY, IT IS THE RESPONSIBILITY OF THE CUSTOMER TO CONFIRM THE INFLUENCE ON THIS PRODUCT AND EQUIPMENT TO BE USED BEFOREHAND, CONDUCT NECESSARY SAFETY DESIGN (INCLUDING REDUNDANT DESIGN, MALFUNCTION PREVENTION DESIGN, etc.), AND PLEASE USE IT AFTER SECURING SUFFICIENT SAFETY OF EQUIPMENT.
 1. SAFETY-RELATED EQUIPMENT SUCH AS AUTOMOBILES, TRAINS, SHIPS, ETC., OR EQUIPMENT DIRECTLY INVOLVED IN OPERATION
 2. AIRCRAFT EQUIPMENT
 3. SPACE EQUIPMENT
 4. MEDICAL EQUIPMENT
 5. MILITARY EQUIPMENT
 6. DISASTER PREVENTION / CRIME PREVENTION EQUIPMENT
 7. TRAFFIC LIGHT
 8. OTHER EQUIPMENT REQUIRING THE SAME PERFORMANCE AS THE ABOVE-MENTIONED EQUIPMENT
 - (2) IN CASES WHERE IT IS NOT INDICATED IN THE REQUESTED STANDARD AND IS USED UNDER CONDITIONS OF USE (INCLUDING CIRCUIT MARGIN, EFFECT OF HEAT GENERATION OF PARTS USED ETC.) THAT CANNOT BE PREDICTED AT THE PRODUCTION STAGE.
 - (3) WHEN USING ULTRASONIC WELDING MACHINE. (THERE IS A POSSIBILITY THAT THE CHARACTERISTIC DEGRADATION IS CAUSED BY THE RESONANCE PHENOMENON OF THE PIEZOELECTRIC MATERIAL. (EXAMPLE; CRYSTAL PIECE))
WE WILL NOT TAKE ANY RESPONSIBILITY FOR THE INFLUENCE OF THE CUSTOMERS' PROCESS.
SO, PLEASE SUFFICIENTLY EVALUATE AT A SAMPLE STEP WHEN YOU USE ULTRASONIC WELDING MACHINE.
 - (4) USING RESIN MOLD MAY AFFECT THE PRODUCT CHARACTERISTIC.
PLEASE MAKE SURE TO TELL OUR SALES CONTACT WHEN YOU USE RESIN MOLD.
WE WILL PERFORM INDIVIDUAL CORRESPONDENCE ABOUT A DELIVERY SPECIFICATION AND A EVALUATION METHOD.
IN ADDITION, IF YOU USE RESIN MOLD WITHOUT CONTACTING US, AND CAUSES DAMAGES AGAINST A CUSTOMER OR A THIRD PARTY, WE WILL NOT BE LIABLE FOR THE DAMAGES AND OTHER RESPONSIBILITIES BECAUSE WE CONSIDER IT IS UNDER SELF-RESPONSIBILITY USING RESIN MOLD.
WE WILL NOT TAKE ANY RESPONSIBILITY FOR THE INFLUENCE OF THE CUSTOMERS' PROCESS.
PLEASE EFFICIENTLY EVALUATE AT A SAMPLE STEP WHEN YOU USE RESIN MOLD.
 - (5) OPERATION IN HIGH HUMIDITY OR CONDENSATION CONDITIONS WILL AFFECT THE CHARACTERISTICS. IF SUCH ENVIRONMENT USE, PLEASE TAKE MEASURES AGAINST WATERPROOF.

- (6) When using this product, please insert a bypass capacitor between the power supply and GND.
(Closer to the product terminal is desirable.)
The bypass capacitor values shown in our specifications and drawings are for reference only.
(They are not guaranteed values.)
In actual use, please select the appropriate bypass capacitor value for your circuit.
NDK shall not be liable for any and all events resulting from or in connection with the use of
this product in a manner that does not comply with the above instruction.
- (7) WHEN PERFORMING IMPROPER HANDLING THAT EXCEEDS THE GUARANTEED RANGE.

Handling of this document and other requests

Please refer to the " Site Guidance" on our website for the handling of information contained
in this document. (<https://www.ndk.com/en/terms/>)