

1. Type NT3225SB

2. Maximum Rating

	Item	Conditions	Rating	unit
1	Supply Voltage	---	-0.3 to +6.5	V
2	Input Voltage	Enable/Disable	-0.3 to +6.5	V
3	Output Voltage	OUTPUT	-0.3 to $V_{CC} + 0.3$	V
4	Storage temp. range	---	-40 to +85	°C

3. Electrical specification

	Parameters	Electrical Spec.				Notes
		Min.	Typ.	Max.	Units	
1	Nominal frequency		32.768		kHz	-
2	Supply voltage (V_{CC})	+2.0	+3.3	+5.5	V	Temperature Compensated Voltage
3	Current consumption		+0.6	+2.0	μA	$V_{CC} = +3.3V$, E/D= GND, No Load Interval of temperature compensation : 30s
			+1.5	+4.0		$V_{CC} = +3.3V$, E/D= V_{CC} , No Load Interval of temperature compensation : 30s
4	Low Level Output voltage (V_{OL})			$0.2 \times V_{CC}$	V	
5	High Level Output voltage (V_{OH})	$0.8 \times V_{CC}$			V	
6	Operating temp. range	-40		+85	°C	
7	Load impedance (Parallel capacitance)			15.0	pF	CMOS Output
8	Frequency stability					
	1.Frequency/Temperature characteristics	-3.8		+3.8	ppm	-10 to +60 °C
		-5.0		+5.0	ppm	-40 to +85 °C
	Based on frequency at +25+/-2 °C					
2.Frequency/Voltage coefficient	-1.0		+1.0	ppm/V	$V_{CC} = +2.0$ to +5.5V at +25+/-2 °C	
3.Frequency tolerance	-3.0		+3.0	ppm	+25+/-2 °C, before reflow soldering, based on nominal frequency	
9	Symmetry	40	50	60	%	$CL = 15pF$
10	Rise Time			70	ns	20% V_{CC} → 80% V_{CC} , $CL = 15pF$, $V_{CC} = +3.3V$
11	Fall Time			70	ns	80% V_{CC} → 20% V_{CC} , $CL = 15pF$, $V_{CC} = +3.3V$
12	Start-up Time		0.1	3.0	S	at -40 to +85°C Typ.: +25°C

4. Reflow soldering

Conditions of temperature profile (Refer to Fig.1)
Soldering peak temp. +260+/-5 °C

5. Marking

- (1) Abbreviation of manufacturer (N mark)
- (2) Lot No.
- (3) Nominal frequency (32kHz)
- (4) Trace code

6. Inspection parameters

Para 3.1, 3.3, 3.4, 3.5, 3.8.1, 3.10, 3.11, 5, 9.2 are inspected.
The other parameters are guaranteed to be within specified characteristics by NDK design.
Inspection data is not submitted for mass production lot. But only if requested, a copy of first lot production data will be submitted.

7. Precaution in the storage

When storing the product in high temperature and high humidity condition for a long time, product characteristics (solderability etc.) and packaging condition may be deteriorated.
The product storage deadline is 1 year after delivery in unopened state. Please use within 1 year.
If you exceed 1 year please check the product characteristics etc, please use.
Please keep the oscillator under below condition.

MSL	Temperature	+5 °C to +45 °C
1	Humidity	10 % to 75 % RH
	Period	1 year max.

(table)

8. Frequency establishment condition

When output frequency is set, we suppose to have the ground pattern under the oscillator.

9. Application drawing

- 9.1 Reliability assurance item
ETS30B-00399
- 9.2 Dimension of External
ETD14B-01921
- 9.3 Packing
ETK17B-00299A
- 9.4 Land pattern
ETD15B-00065
- 9.5 Marking
ETH11B-00554

11. Notes on use

11-1 Even if the appearance color etc. of the product differs by purchasing the component parts by more than two companies, there is no influence on the characteristics and reliability.

11-2 IN THE CASE OF THE FOLLOWING ITEMS, WE ARE NOT RESPONSIBLE FOR WARRANTY / COMPENSATION.

(1) WHEN PRODUCTS OF THIS SPECIFICATION ARE USED FOR EQUIPMENT RELATED TO HUMAN LIFE OR PROPERTY, IT IS THE RESPONSIBILITY OF THE CUSTOMER TO CONFIRM THE INFLUENCE ON THIS PRODUCT AND EQUIPMENT TO BE USED BEFOREHAND, CONDUCT NECESSARY SAFETY DESIGN (INCLUDING REDUNDANT DESIGN, MALFUNCTION PREVENTION DESIGN, ETC.), PLEASE USE IT AFTER SECURING SUFFICIENT SAFETY OF EQUIPMENT.

- ① SAFETY-RELATED EQUIPMENT SUCH AS AUTOMOBILES, TRAINS, SHIPS, ETC., OR EQUIPMENT DIRECTLY INVOLVED IN OPERATION
- ② AIRCRAFT EQUIPMENT
- ③ SPACE EQUIPMENT
- ④ MEDICAL EQUIPMENT

- ⑤ MILITARY EQUIPMENT
- ⑥ DISASTER PREVENTION / CRIME PREVENTION EQUIPMENT
- ⑦ OTHER EQUIPMENT EQUIVALENT TO THE ABOVE-MENTIONED EQUIPMENT

(2) IN CASES WHERE IT IS NOT INDICATED IN THE REQUESTED STANDARD AND IS USED UNDER CONDITIONS OF USE (INCLUDING CIRCUIT MARGIN ETC.) THAT CANNOT BE PREDICTED AT THE PRODUCTION STAGE.

(3) WHEN USING ULTRASONIC WELDING MACHINE. (THERE IS A POSSIBILITY THAT THE CHARACTERISTIC DEGRADATION IS CAUSED BY THE RESONANCE PHENOMENON OF THE CRYSTAL PIECE.)

(4) WHEN PERFORMING IMPROPER HANDLING THAT EXCEEDS THE GUARANTEED RANGE.

11-3 This product cannot be used for equipment related to the safety of automobiles or equipment directly involved in operation. (Example: air bag, TPMS, engine control, steering control, brake control etc.)

11-4 If you use resin for fixing components during manufacturing, please keep resin from adhering to the oscillator.

12. Other Requests

12-1 Please use this specification only for confirmation of the specification of this product.

12-2 If there is a change request, please contact within three weeks from issue date. If there is no communication, we will deliver the product under the contents of this specification. In addition, if the product delivery date is within 3 weeks and there is a change request, we will consult the processing separately.

12-3 Notes that are described in this document, if you did not comply with the prohibitions, and other please, including the failure correspondence or compensation or damage, we cannot assume the responsibility, please understand.

13. Prohibited items

Be sure to use the product under the following conditions. Otherwise, the characteristics deterioration or destruction of the product may result.

(1) Reflow soldering heat resistance

Peak temperature: +265 °C

Heating: +225 °C or higher, 90 sec

(2) Manual soldering heat resistance

Pressing a soldering iron of +410 °C on the terminal electrode for five seconds.

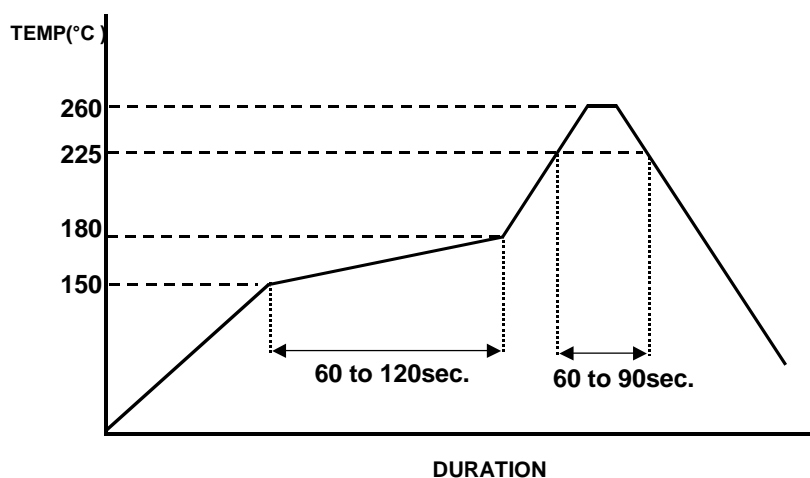

(Fig.1)

Reliability assurance item

(page: 1/1)

No.	Test Item	Test Methods	Specification Code
1	Vibration	5 to 26Hz: 1.52mm (total amplitude) 26 to 500Hz: 19.6m/s ² 20 minutes per 1 cycle. 2 hours for each 3 planes.	A
2	Shock	Half sine wave 6ms, 980 m/s ² . 3 times for each 3 planes.	A
3	Drop Test	Drop freely on the concrete from the height of 150cm With jig(150g). 3time for each 6 planes.	A
4	Humidity	+60°C, 95% RH for 48H. And normal temperature, with normal humidity for 24H.	A

Specification code	Specification
A	After the test, shall meet electrical specification.

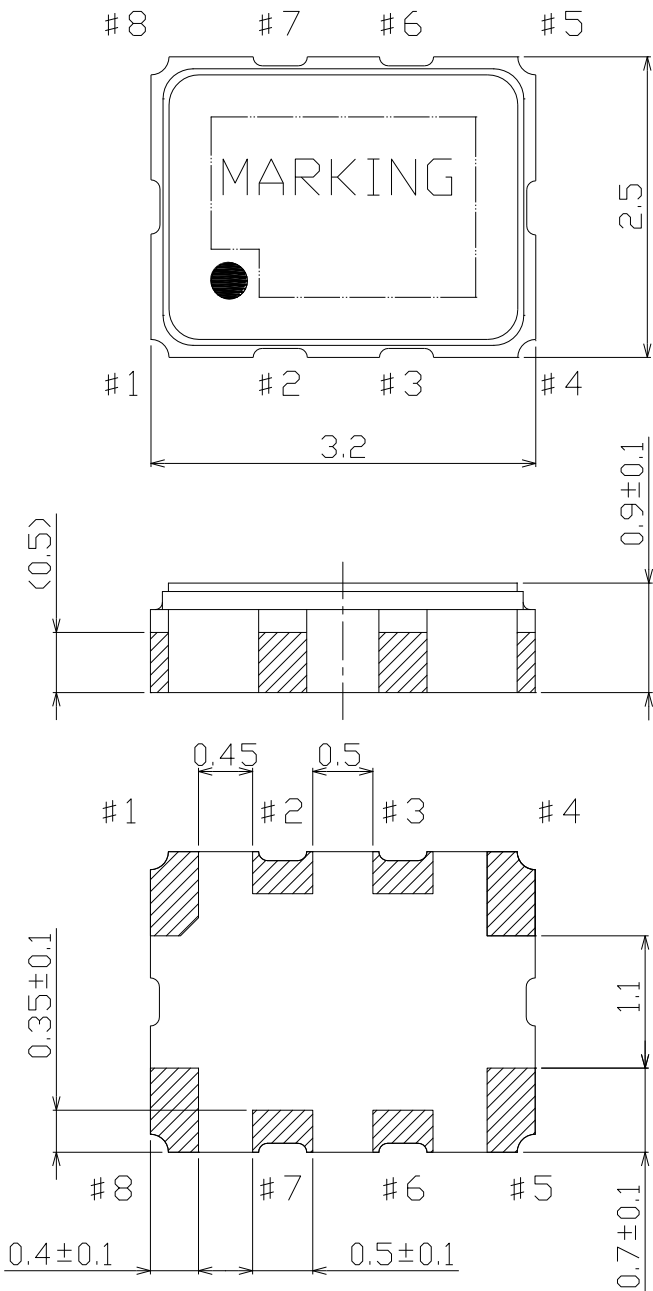
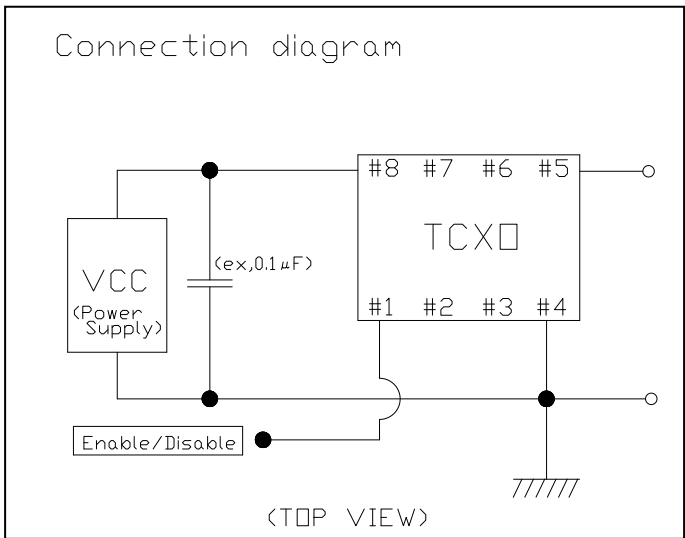

Terminal land connections	
#1	Enable / Disable
#2	NC
#3	NC
#4	GND
#5	OUTPUT
#6	NC
#7	NC
#8	V _{CC}

* A capacitor of value 0.1µF or more between V_{CC} and GND is recommended. (Please arrange near the RTC as much as possible.)

Date of Revise	Charge	Approved	Reason	
Drawn	Date: 29.Dec.2015 Name: M.Fukunaga	Third Angle Projection Dimension:mm	Tolerance +/- 0.2	Scale 15/1
Designed	29.Dec.2015 M.Fukunaga	Title Dimension of External	Drawing No. ETD14B-01921	Rev. B
Checked	29.Dec.2015 K.Koyama			
Approved	29.Dec.2015 K.Moriya			

NIHON DEMPA KOGYO CO., LTD.

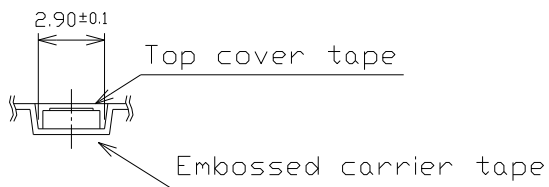
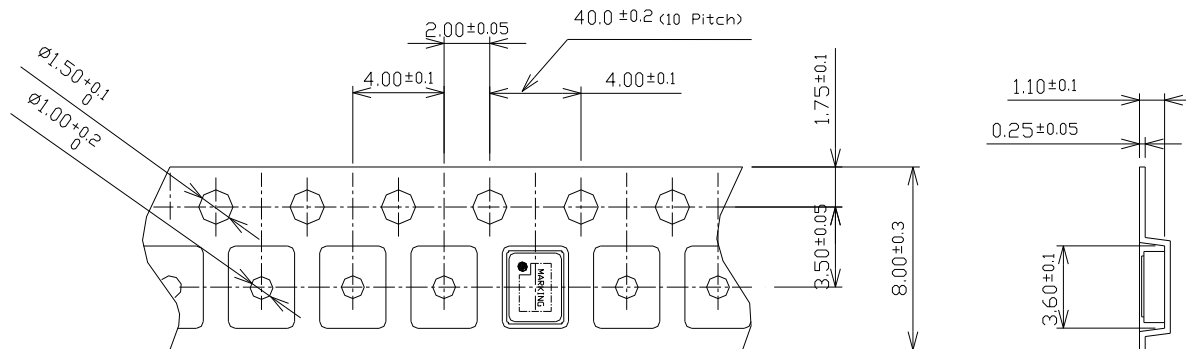

	Embossed carrier tape	Top cover tape
Materials	PS	PET + PE + Adhesive layer
Disposition	Antistatic	Antistatic

	Date of Revise	Charge	Approved	Reason	
A	18.Nov.2010	R.Yoshizaki	K.Moriya	Amount addition	
	Date	Name	Third Angle Projection	Tolerance	Scale
Drawn	19.May.2010	M.Kashiwamura	Dimension:mm	----	3/1
Designed	19.May.2010	M.Kashiwamura	Title	Drawing No.	Rev.
Checked	19.May.2010	K. Moriya			
Approved	19.May.2010	K. Moriya			
			Packing	ETK17B-00299 (1/3)	A

NIHON DEMPA KOGYO CO., LTD.

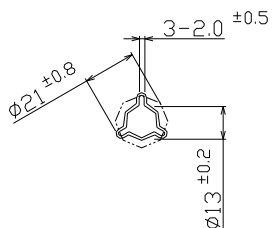
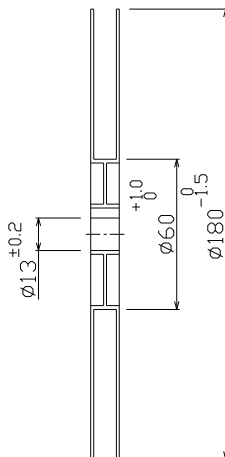
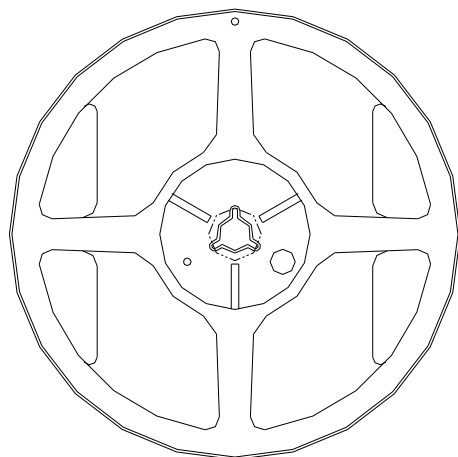

Materials : PS
Disposition : Antistatic

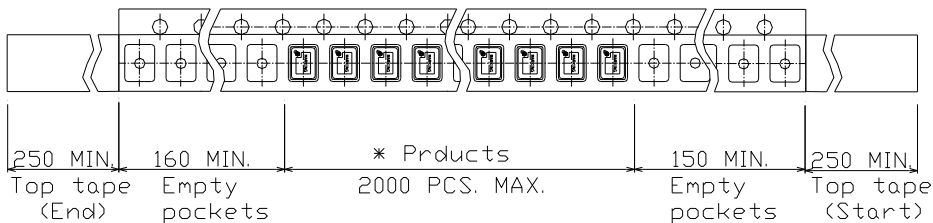

* There are no vacant pockets for this area.

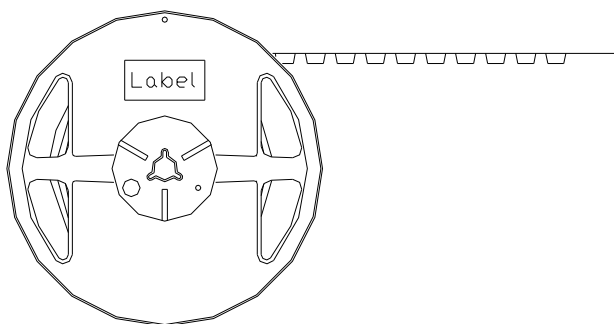

	Date of Revise	Charge	Approved	Reason	
A					
	Date	Name	Third Angle Projection	Tolerance	Scale
Drawn	19.May.2010	M.Kashiwamura	Dimension:mm	-----	-----
Designed	19.May.2010	M.Kashiwamura	Title	Drawing No.	Rev.
Checked	19.May.2010	K. Moriya			A
Approved	19.May.2010	K. Moriya			
Packing			ETK17B-00299 (2/3)		

NIHON DEMPA KOGYO CO., LTD.

-2000pcs.Max./Reel
 -5 Reels Max./Carton

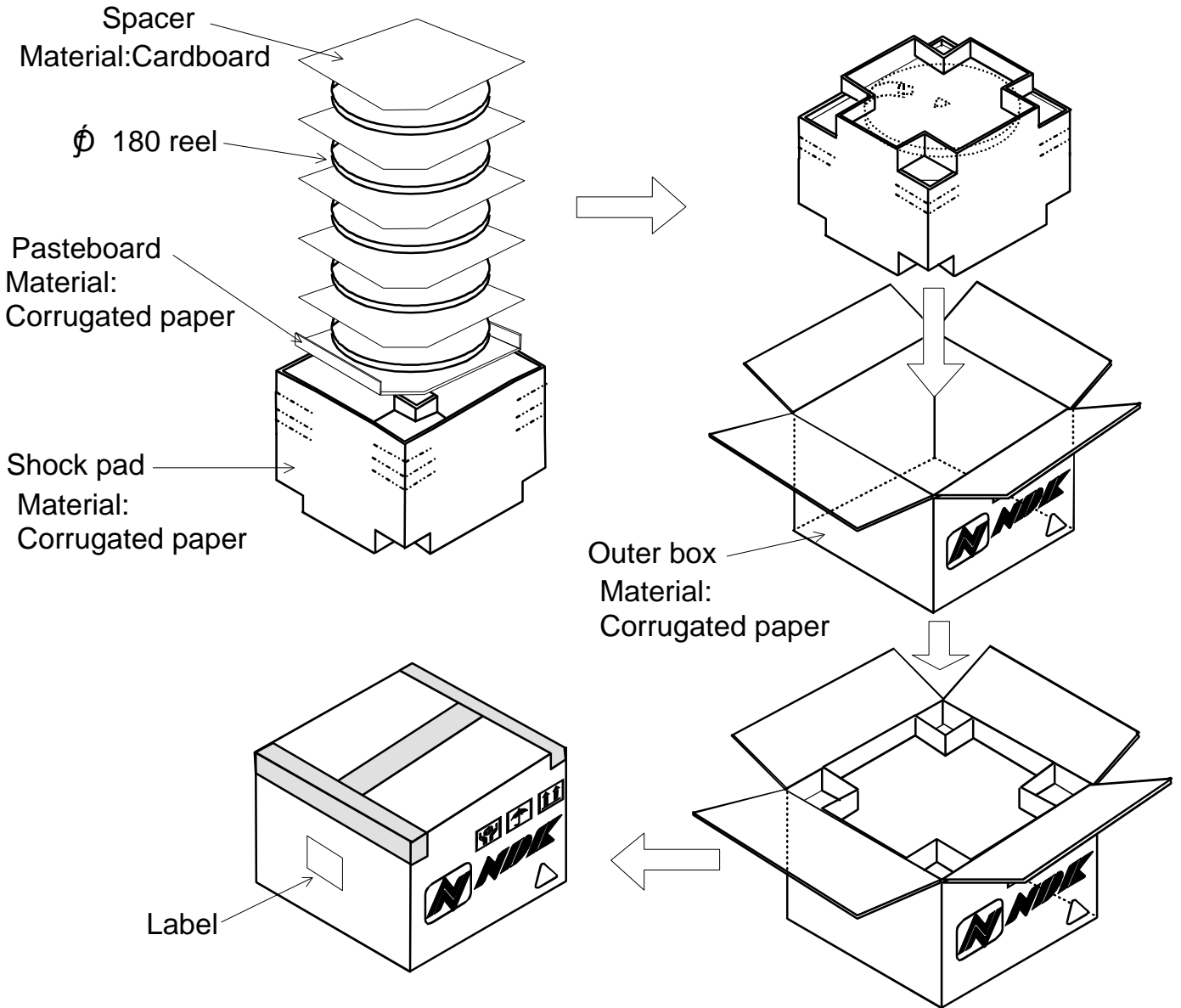

	Date of Revise	Charge	Approved	Reason	
A					
	Date	Name	Third Angle Projection	Tolerance	Scale
Drawn	19.May.2010	M.Kashiwamura	Dimension:mm	----	----
Designed	19.May.2010	M.Kashiwamura	Title	Drawing No.	Rev.
Checked	19.May.2010	K. Moriya			
Approved	19.May.2010	K. Moriya			
Packing			ETK17B-00299 (3/3)		A

NIHON DEMPA KOGYO CO., LTD.

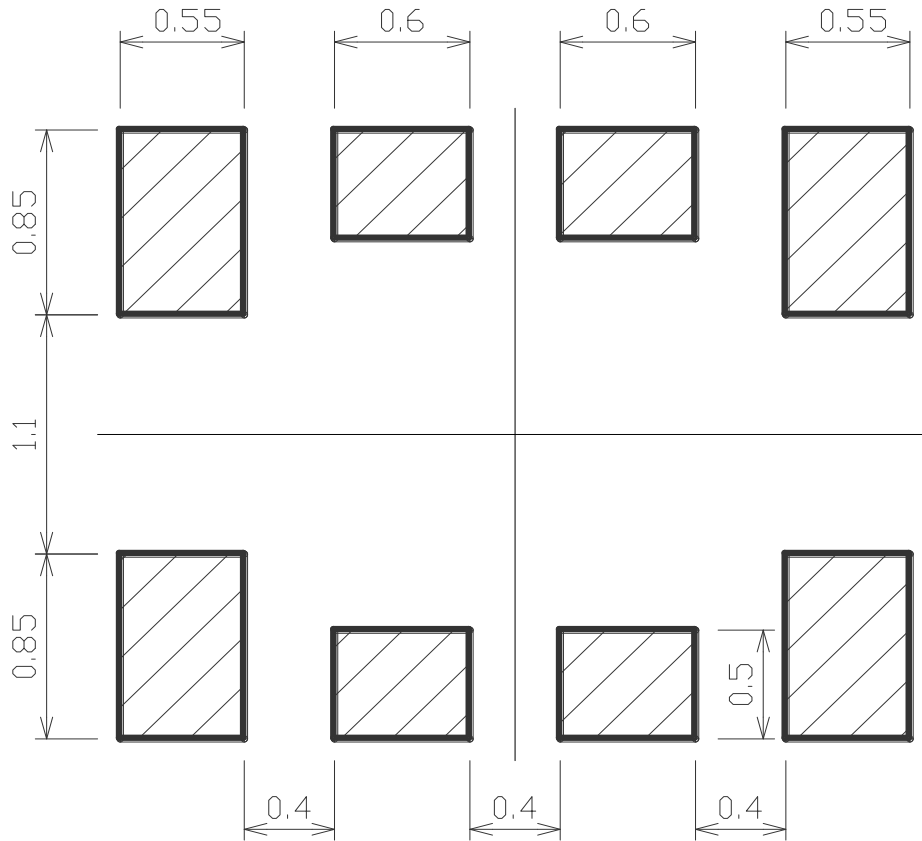

Note) Please reserve a large ground pattern on the PCB where the oscillator is installed.

Date of Revise		Charge	Approved	Reason	
	Date	Name	Third Angle Projection	Tolerance	Scale
Drawn	22.Apr.2014	M.Kashiwamura	Dimension:mm	----	30 / 1
Designed	22.Apr.2014	M.Kashiwamura	Title	Drawing No.	Rev.
Checked	22.Apr.2014	S.Murase			
Approved	22.Apr.2014	S.Murase			
			Land pattern	ETD15B-00065	-

NIHON DEMPA KOGYO CO., LTD.

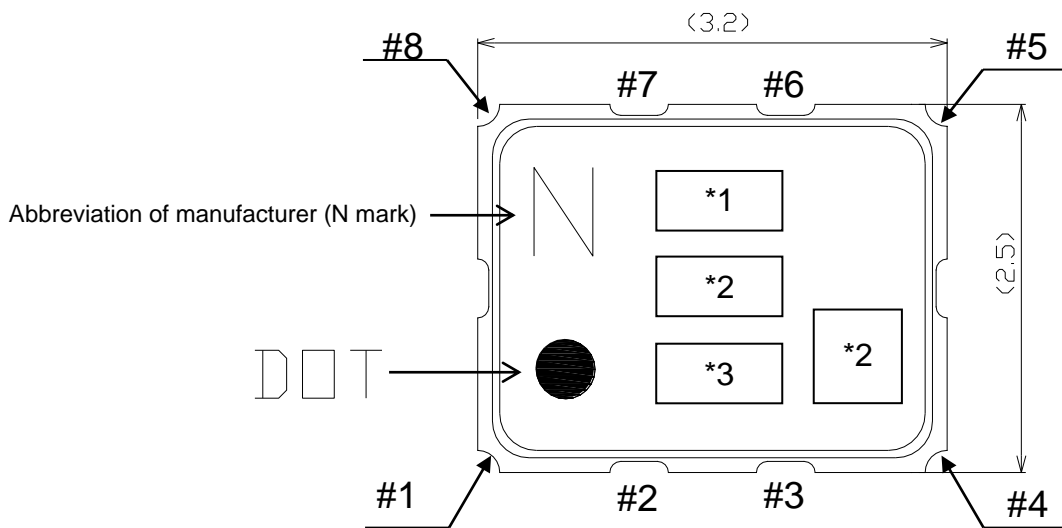

Terminal land connections: Please refer to “Dimension of External”.

(Marking Contents)

*1 Lot No.



Year Code (Last one digit)

Month Code (see table)

Month	1	2	3	4	5	6	7	8	9	10	11	12
Month Code	1	2	3	4	5	6	7	8	9	O	N	D

Following No.

*2 Trace code

Trace code indicate production date and production line number.

*3 Nominal Frequency

- A unit (Hz) is not written.
- Under a decimal point omits.

(Example: 32.768kHz → 32k)

Marking Method : Laser Trimming

	Date of Revise	Charge	Approved	Reason
	Date	Name	Third Angle Projection	Tolerance
Drawn	29. Oct. 2015	Y.Inazawa	Dimension:mm	---
Designed	29. Oct. 2015	Y.Inazawa	Title Marking	Drawing No. ETH11B-00554
Checked	29. Oct. 2015	K.Koyama		
Approved	29. Oct. 2015	K. Moriya		
				Scale ---
				Rev.

NIHON DEMPA KOGYO CO., LTD.